



FranklinWH System Installation Guide

aPower S, SKU: APRS-10K15V1-US

aGate X 1.3 & aGate X 1.3.1, SKU: AGT-R1V2-US; AGT-R1V3-US

Floor mounting bracket, SKU: ACCY-FMBV2-US

©2026 FranklinWH Energy Storage Inc. All rights reserved.

All information in this Manual is subject to the copyright and other intellectual property rights of FranklinWH Energy Storage Inc. This manual may not be modified, copied or reproduced, in whole or in part, without the prior written permission of FranklinWH Energy Storage Inc.

Please visit [FranklinWH Support](#) for the latest FranklinWH documents.

All brands and trademarks mentioned in this document are the property of their respective owners, and their use in this document does not imply the sponsorship or recognition of their products or services.

Please read this document carefully to ensure the best reliability of the product and your warranty eligibility. For further information about the warranty, please refer to the **FranklinWH Limited Warranty**.

This document is intended for use by professional installation and maintenance service providers only and no statements, information or recommendations in this document constitute any express or implied warranty.



Please read this document carefully before installing or using the FranklinWH equipment. Failure to follow any instructions or warnings in this document may result in damage to the equipment, personal electric shock, severe injury, or even death.

Product Information

The FranklinWH System is composed of aPower, aGate, the FranklinWH App, and other electrical and software components.

FranklinWH Energy Storage Inc. (FranklinWH) reserves the right to make any improvements to the product, and the contents in this document shall be subject to updates without further notification.

All images and pictures provided in this Manual are only for demonstration purposes and may differ in detail from the product, based on the product version.

FCC Compliance

This equipment has been tested and found to comply with the limits for a Class B digital device, pursuant to part 15 of the FCC Rules. These limits are designed to provide reasonable protection against harmful interference in a residential installation. This equipment generates, uses and can radiate radio frequency energy and, if not installed and used in accordance with the instructions, may cause harmful interference to radio communications. However, there is no guarantee that interference will not occur in a particular installation. If this equipment does cause harmful interference to radio or television reception, which can be determined by turning the equipment off and on, the user is encouraged to try to correct the interference by one or more of the following measures:

- Reorient or relocate the receiving antenna.
- Increase the separation between the equipment and receiver.
- Connect the equipment into an outlet on a circuit different from that to which the receiver is connected.
- Consult the dealer or an experienced radio/TV technician for help.

MPE caution (if an FCC certified RF module is inserted in and the separation distance is indicated in the FCC grant of RF module).

To satisfy FCC / IC RF exposure requirements, a separation distance of 8 in. (20 cm) or more should be maintained between the antenna of this device and persons during device operation.

To ensure compliance, operations at closer than this distance is not recommended.

Feedback

If you have any questions or comments, please send us an email at: service@franklinwh.com

Disposal of Scrapped Products

Scrapped products (including their internal chemicals and electrical materials) should not be disposed of with household waste. Please refer to your local laws and regulations regarding disposal.



CONTENT

Safety Statements	1
Safety Symbols	1
Safety Instructions for Operation	2
Safety Instructions for Installation Site	5
Fire and Other Emergency Situations	6
FranklinWH System Overview	7
Whole-Home Backup System	8
Partial Backup System	8
Installation Preparations	9
Mechanical Specifications	9
Site Planning	10
Tools Needed	15
Items Provided by Installers	17
Unboxing	18
Unbox the aGate	18
Unbox the aPower	19
Installation	20
aGate Installation	20
Remove the aGate Door and Inner Panel	20
Prepare aGate Cable Entries	22
Enlarge or Drill New Holes (if necessary)	23
Mount the aGate on a Wall	23
Install Breakers as Needed	25
aPower Installation	27
Wall-Mounted Installation	27
Free-Standing Floor-Mounted Installation using an optional Floor-Mounting Bracket	33
Install a Combiner Box (if needed)	35
System Wiring	35







Install Electrical Conduit in the aPower	35
Prepare the Communications Wiring	38
Run Electrical Wiring in the aGate	43
Establish the PV Power Connection	46
Connect the aPower(s) to the aGate.....	51
Mixed Configuration: aPower S, aPower 2, and aPower X 1.3 Wired in Parallel.....	56
Install a Rapid Shutdown Switch.....	61
Install an optional Emergency Power-Off Switch.....	63
Complete Installation.....	66
Install the aPower Exterior Cover	66
Re-Install the aGate Door and Inner Panel.....	70
Commissioning and Acceptance	71
Appendix 1: Allowed Breakers.....	72
Appendix 2: Datasheet	77
Appendix 3: Revision History.....	81

Safety Statements











This Guide includes important information about the FranklinWH System. Please read this Guide carefully before installation, maintenance, or use. Failure to follow any instruction in this Guide may lead to risks of equipment damage, electric shock, severe personal injury and even death, and may also void the warranty ([FranklinWH Support](#)).











The DANGER, WARNING, and NOTE alerts are supplemental to the safety instructions and are not exhaustive.

Safety Symbols

	DANGER: This indicates a hazardous situation, which if not avoided, could result in serious injury or death.
	DANGER: There are fire risks in the battery packs.
	WARNING: This indicates a situation where failure to follow instructions may be a safety hazard or cause equipment malfunction. Use extreme caution and follow instructions.
	NOTE: This indicates information important for optimal system operation. Follow instructions.
	PROTECTIVE GROUNDING TERMINAL: This indicates the position of grounding connection on the equipment.
 5 Minutes	WAIT TIME: It means there are electric shock risks inside the equipment, please wait 5 minutes before proceeding.
	ELECTRONIC DEVICE: DO NOT THROW AWAY. Scrapped electronic products and batteries cannot be disposed of together with household wastes. Please consult your local laws and regulations for further information.

Safety Instructions for Operation













	DANGER: The installation, wiring, maintenance, transportation, and handling of each aGate and aPower should follow local laws, regulations and standards, and the Safety Instructions in this Guide serve as supplementation to the laws, regulations, and standards.
	DANGER: Before any electrical operation starts, please turn off the grid power supply switch, generator input switch, the PV input switch, the load switch, and lock the switches. If the switches cannot be locked, please lock the distribution box where the switches are installed. A warning sign, Out of Operation , or Do NOT Turn On , should be hung.
	DANGER: Both aPower and aGate are electrical equipment, and improper operation may lead to electric shock, energy hazards, or chemical hazards. Please do NOT open the cabinet or disassemble without express direction from the FranklinWH service team.
	DANGER: Only FranklinWH certified and qualified technicians can install, maintain, or replace aGate and aPower equipment or wiring. They must wear personal protective equipment (PPE) during operation.
	DANGER: It is strictly forbidden to work on or operate the system alone. For safety, make sure that there is someone around you who can help.
	DANGER: It is strictly forbidden to install, maintain, or handle the system outdoors during bad weather conditions, such as lightning, thunder, rain, snow, or strong winds.
	DANGER: In case of a battery fire, please take action as instructed in the Safety Data Sheet .
	DANGER: The aPower must be carefully handled and installed using lifting equipment to avoid injury to installers or the aPower.
	DANGER: During the transport and handling of aGate and aPower units, extreme care is required to avoid dropping, bumping, stomping, or inverting the equipment. To prevent potential damage, please keep all aPower units in their packaging until ready to install.
	DANGER: During use, storage, and transport, ensure that the ambient temperature of an aPower does not exceed 122° F (50° C), that it is not near flammable items, and that the cooling system and vents are not blocked.
	DANGER: Do not attempt to take apart, repair and/or modify an aGate or aPower without the authorization of FranklinWH. And it is prohibited to open the battery pack chamber in any situation. Otherwise, it may lead to safety hazards and void your warranty.

	DANGER: To prevent misoperation, ensure that the upstream and downstream switches are disconnected and padlocked during installation or maintenance.
	DANGER: If an aPower or aGate is found damaged (except for minor defects in exterior painting) after it is unboxed or malfunctioning on installation, please do NOT operate it and contact your after-sales service provider for support.
	DANGER: Before any installation and commissioning of an aPower, please keep the round switch button on the right part of aPower off (extended, flush with the case) and prevent the ON/OFF switch from being operated by mistake.
	DANGER: If the aPower battery is leaking electrolyte, smoking, or catching fire, if it is safe to do so, disconnect the AC power from the FranklinWH System, and turn off the aPower switch to stop charging and discharging the battery.
	DANGER: The installation of the FranklinWH System must comply with all applicable codes and requirements set by the local AHJ and/or the state.
	DANGER: Both electric connection and electric isolation need to comply with the local standards and National Electric Codes (NEC), ANSI/NFPA 70 or Canadian Standards Association CSA C22.1.
	DANGER: The installer needs to provide suitable conduits and cables, and complete the installation process in accordance with the local regulations and UL514B.
	WARNING: For maintenance purposes, do NOT use any parts or fittings that are not listed in this Guide or that are purchased from any source other than FranklinWH or its recognized dealers.
	WARNING: Measures should be taken to prevent foreign objects from entering any aPower or aGate.
	WARNING: Do NOT use paint on any part of an aPower or aGate, whether internal or external, especially on the protective cover except for exterior paint that has been worn out or damaged in the transportation, installation, or maintenance process. The damaged part can be repaired with paint or topcoat of the same color.
	WARNING: Do NOT connect an aPower directly to the PV inverter.
	WARNING: Before installation, do not store an aPower on site for more than one month. After installation, do not turn on the aPower before connecting the PV and grid, otherwise the battery will be depleted due to a long period of time without charging.



WARNING: The operation of the FranklinWH System requires an Internet connection. Extended offline operation may result in a voided warranty. Please refer to [FranklinWH Support](#) for information.

Safety Instructions for Installation Site

	DANGER: The installation site of aPower and aGate units should be kept away from heating devices, or any source of heat and/or fire.
	DANGER: The aPower and aGate installation area should be well-ventilated to maintain the ambient temperature within -4° F to 122° F (-20° C to 50° C) and the relative humidity between 5% and 95%.
	DANGER: The aPower and aGate installation area shall not be located in areas subject flooding or standing water. The aPower battery and integrated inverter are rated IP67, while the wiring compartment is rated IP56.
	DANGER: The aPower and aGate installation area should be away from flammable and explosive materials.
	DANGER: The installation site for the FranklinWH System must meet all applicable codes and standards.
	WARNING: Before the installation starts, engineers should check and locate the embedded electric wires and water pipes to avoid potential property damage and personal injury during the installation process.
	WARNING: aPower units may be installed on the floor or on walls; floor installation is recommended. If wall-mounted, the wall should be able to provide sufficient bearing capacity.
	WARNING: The aPower and aGate installation site should have no water source above it or in the vicinity, including water pipes, shower, faucet, and containers of liquids.
	WARNING: The installation site should be properly leveled and hardened if the aPower is floor mounted. If there is grass nearby, a layer of cement or slab stone must be placed on the projection area around the equipment to prevent grass growth and protect the equipment.
	WARNING: Do NOT clean aPower and aGate units with cleaning agents or expose them to flammable or irritant chemicals or their vapors.
	WARNING: It is required that either Ethernet or Wifi connectivity is provided at the aGate installation site. Ethernet and Wifi connections are more reliable, but 4G connection are also possible, though not suggested as the primary method.
	RECOMMENDATION: It is recommended to avoid a direct south-facing orientation when installing outdoors for optimal performance.

Fire and Other Emergency Situations

Fire:

- Shut off the aPower breaker on the aGate, if it is safe to do so.
- Evacuate to a safe area.
- Contact 911 as soon as it is safe to do so.
- Use approved fire extinguishing devices, if it is safe to do so.

Flood:

- Shut off the aPower breaker on the aGate if it is safe to do so.
- If the wiring sections of an aPower or aGate are submerged, please stay away from the water. Electric leakage may result in electric shock.
- Drain the water to protect the system if it is safe and possible.
- If water rises to the battery level, please call your installer for inspection. If the water level is below the battery chamber, please allow the site to completely dry.

Abnormal noise, odor, or smoke:

- Shut off the aPower breaker on the aGate, if it is safe to do so.
- Check and ensure your aPower is well ventilated and the vents are not blocked.
- Keep the installation site well ventilated.
- Call your after-sales service for support.

FranklinWH System Overview

The FranklinWH System is a comprehensive whole-home energy solution designed for residential applications requiring energy independence, cost optimization, and grid resilience. The system consists of three key components:

- **aGate:** An intelligent power management unit that provides whole-home power control.
- **aPower S:** A solar and energy storage battery unit featuring an integrated battery management system (BMS) and inverter. The aPower S batteries support both DC-coupled and AC-coupled solar configurations. However, DC connected directly to aPower S is recommended for high energy efficiency during new solar and battery installations.
- **FranklinWH App:** An app that helps both installers and homeowners configure, monitor and manage the system in real-time.

System Capabilities

The FranklinWH System manages and stores energy from multiple sources including the electrical grid, photovoltaic (PV) systems, certain approved electric vehicles (EVs), and backup generators. This stored energy can be strategically deployed to:

- Provide reliable backup power during grid outages (whole-home or partial-home backup)
- Optimize energy costs through time-of-use rate management and peak demand reduction
- Maximize PV self-consumption by storing excess solar generation for evening and nighttime use
- In a multiple-tariff use-case, selectively charge from non-exporting PV and allow exporting (net-metered or other) PV to export to the grid in compliance with evolving utility and regulatory standards
- Enable system owner and operator participation in Virtual Power Plant (VPP) and similar grid services programs

Operation and Control

System owners and operators can monitor and operate their systems remotely through the FranklinWH App, providing real-time visibility and control over their home energy management. The system's AC/DC coupling and advanced energy management technologies deliver reliable household backup and intelligent load control capabilities suitable for residential installations.

Important: Load selection for whole-home versus partial-home backup configurations must be completed during the system design phase.

Whole-Home Backup System

In the whole-home backup system, all household loads, except for those on Smart Circuits, are connected via the Main Panel to the backup port of the aGate. If the grid fails, the FranklinWH System will power all household energy loads.

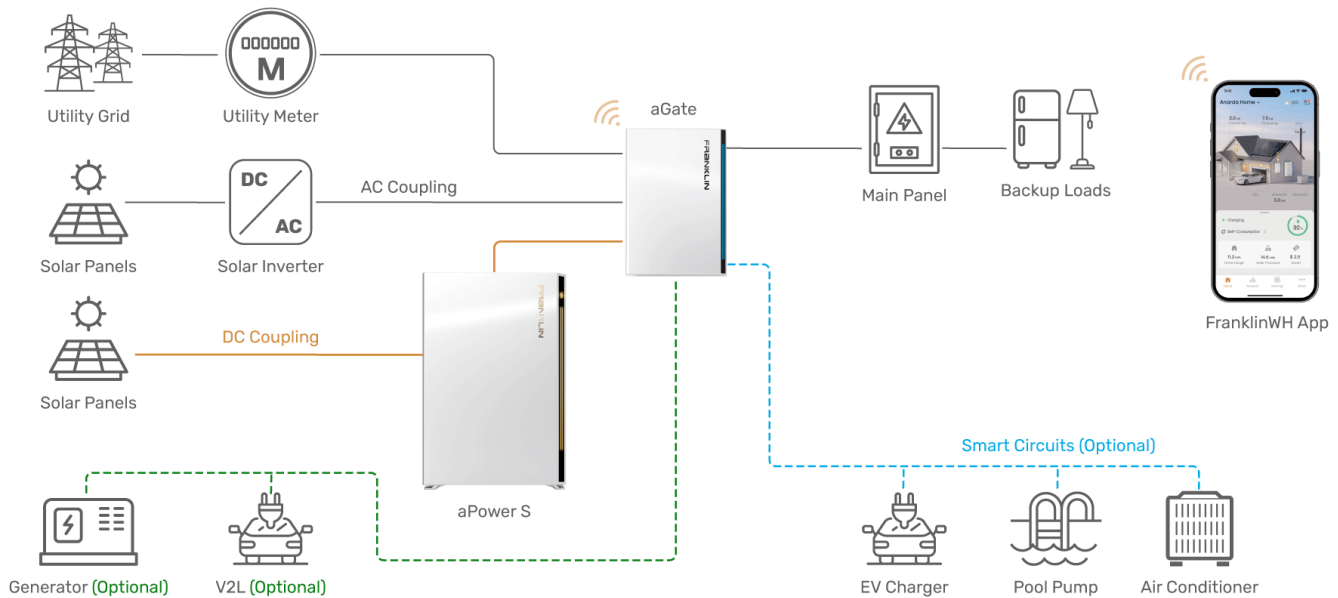

Partial Backup System

If you select a partial backup configuration, you need to identify backup loads during system configuration. Connect the backup loads (except for Smart Circuit loads) to the aGate backup port and connect the non-backup loads to the aGate non-backup port. If the grid fails, the system will only power the backup loads during an outage.

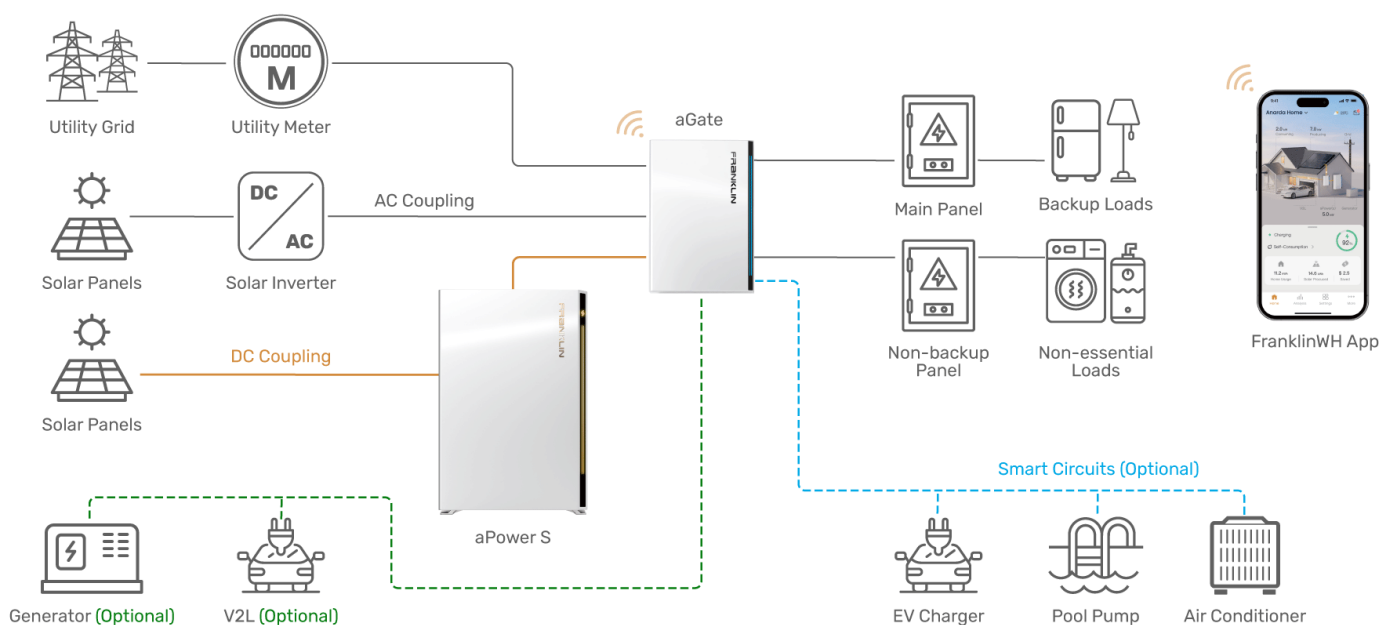

Installation Preparations

Mechanical Specifications

aGate X	
Dimensions (H × W × D)	31.5 in × 21.7 in × 6.3 in (800 mm × 550 mm × 160 mm)
Weight	38.6 lb. (17.5 kg)



aPower S	
Dimensions (H × W × D)	45.2 in × 29.5 in × 11.8 in (1149 mm × 750 mm × 300 mm)
Weight, aPower S Complete	388 lb. (176 kg)
Weight, without Cover	365 lb. (166 kg)

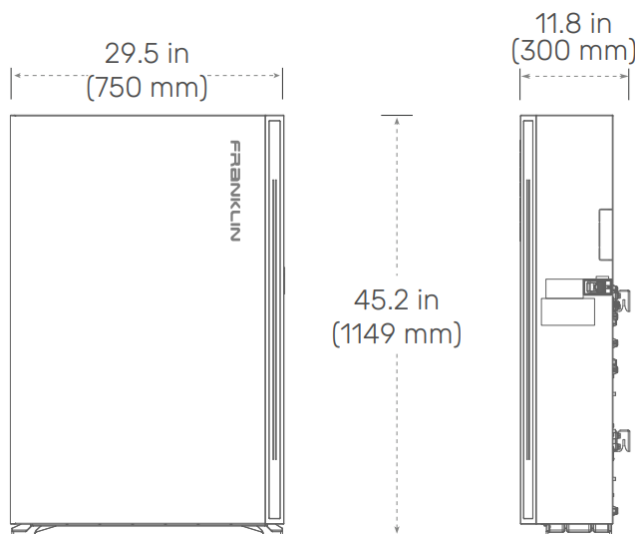

Site Planning

1. Plan installation position

NOTE

The installation location must avoid water and power conduits. Refer to all applicable local codes and standards.



The operating temperature range for the aPower is -4° F to 122° F (-20° C to 50° C), extendable to 131° F with output deration. The aPower S uses a heating blanket (pre-installed in the battery) for cold temperature reliability. If the installation site experiences prolonged cold weather, it is recommended to install the batteries indoors in a regulated environment.

It is best practice to install the aPower and aGate in an area protected from direct sunlight, rain and snow. Extreme heat from direct sunlight may derate the output or affect equipment longevity beyond the warranty period for aPower and aGate.

- a) Choose a mounting location that can bear the weight of the aPower and aGate.



NOTE: The clearance details below are general guidelines for spacing in accordance with NEC requirements. For countries or regions where NEC requirements are not applicable, please consult with your AHJ or Utility before finalizing the spacing.

aGate

There should be at least 6 in. (0.15 m) of clearance from the top of aGate to the ceiling, and 36 in. (0.91 m) of clearance in front of the aGate.

The recommended distance between the bottom of aGate and the ground is 48 in. (1.2 m), not exceeding 52 in. (1.3 m). The maximum distance between the power switch button on the aGate and the ground shall not exceed 79 in. (2 m) per the NEC requirements.

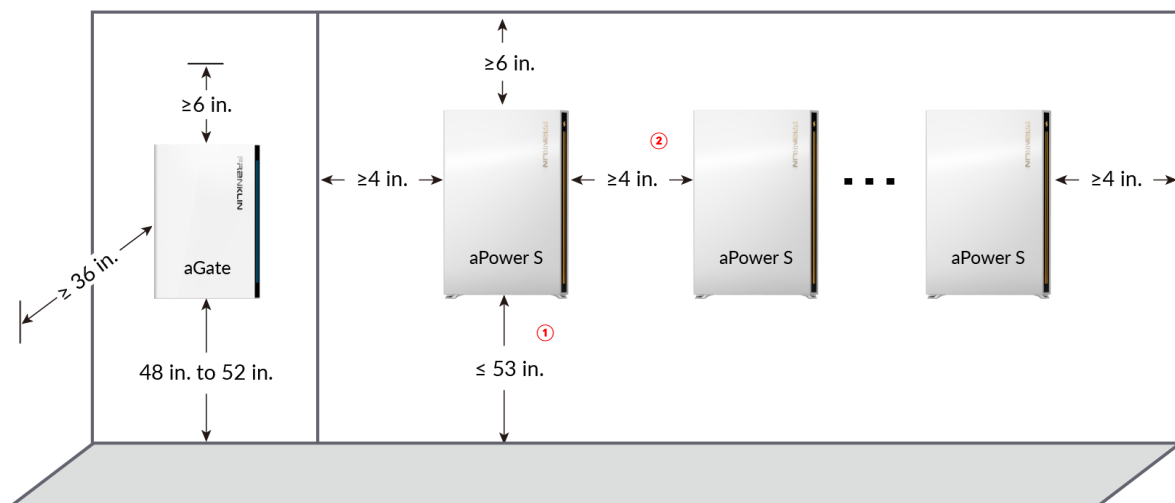

- ① NEC 408.4(A) requires the aPower switch to be no more than 79 in. (2 m) from the ground.
- ② 4 in. (0.1 m) between adjacent aPower units is UL9540A required clearance. FranklinWH recommends a clearance of 14 inches for optimal operation of the electric drills and screwdrivers during installation.

aPower

There should be a minimum clearance of 6 in. (0.15 m) from the top of aPower to the ceiling.

For an aPower mounted on a wall, the maximum distance between the bottom of the aPower and the ground shall be ≤ 53 in. (1.35 m) i.e., **the maximum distance between the aPower switch button and the ground shall not exceed 79 in. (2 m) per NEC 404.8(A) requirements.**

The minimum clearance between adjacent aPower units and from side wall is 4 in. (0.1 m). Ensure adequate spacing for connection access.

The aPower S can be installed in multiple configurations, including horizontal, vertical, and front-to-back orientations. Please note that FranklinWH currently does not offer any accessories or mounting bracket for front-to-back stacking. All configurations and clearances have been tested and approved in accordance with UL 9540A:2019 (5th Edition). Ensure that all battery installations, regardless of configuration, comply with applicable national and local codes and regulations. For more information, contact engineering@franklinwh.com.

Description	Space
Vertical stacking clearance	≥ 6 inch (150 mm)
Front-back clearance	≥ 2.3 inch (58 mm)
Wall height for vertical stacking	≥ 8.5 ft (2.6 m)
Space to room top	≥ 6 inch (150 mm)
Vertical stacking depth	≥ 12 inch (305 mm)
Front-back stacking depth	≥ 25 inch (635 mm)

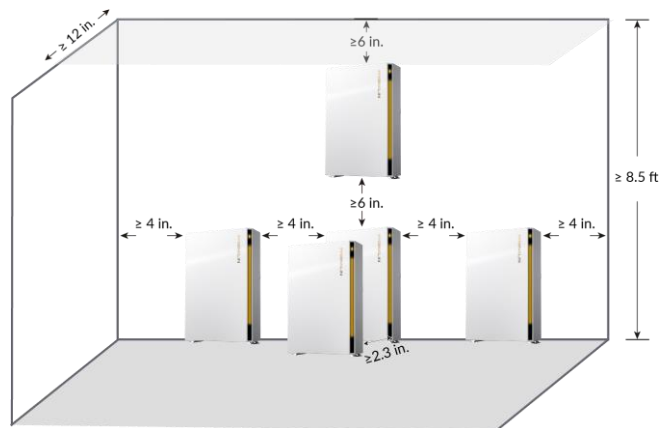

- b) The system requires an internet connection. All signal transfers between aPower and aGate units, the generator, and the router are provided by a CAN bus, network cables or other signal transmission cables. Long distances will likely adversely affect the quality and speed of communications, negatively impacting equipment operations. Recommended maximum cable lengths listed below.

Connection	Maximum cable length
aPower to aGate	164 ft (50 m)
Split CT to aGate	49 ft (15 m)

2. Plan the positions of equipment knockout entries

aGate knockout entries

The positions of the knockout entries on an aGate are as shown below. The following scenarios offer variations on the cable entry points of an aGate to accommodate variations in the existing residential wiring layout.

The knockout holes on the left and lower panels of aGate are 1.38 in. (35 mm) in diameter, while the plug hole on the upper panel is 2.49 in. (63 mm) in diameter. If the knockout holes do not match the electrical conduits in hub diameter, additional reducing fittings will be needed to achieve the required IP grade.

WARNING



It is recommended to install cables through the bottom of the aGate.

If a top inlet cable is installed, additional waterproofing measures must be taken.

Scenario 1: aGate and electrical conduits share the same side of the wall.

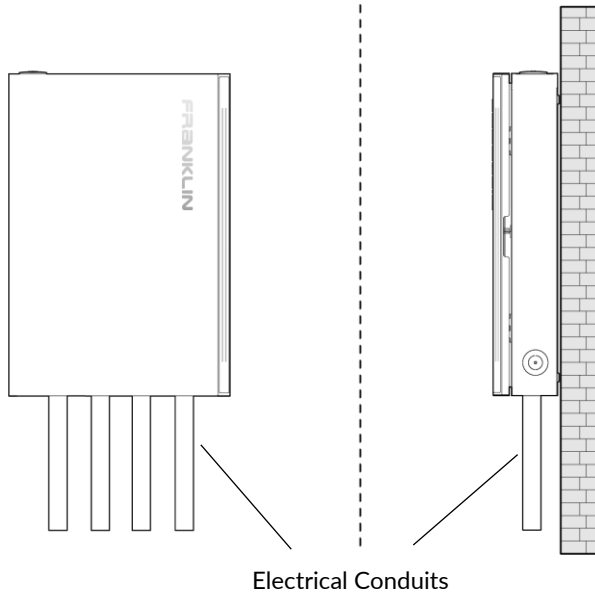

If the aGate is installed outdoors, the electrical conduit is connected to aGate through the cable inlet on the upper panel. Water-proof sealant or caulk should be used between the reducing fitting, hub, electrical conduit, and aGate to enhance the water tightness.

Scenario 2: Cables are run in electrical conduits and enter aGate from inside or through the wall.

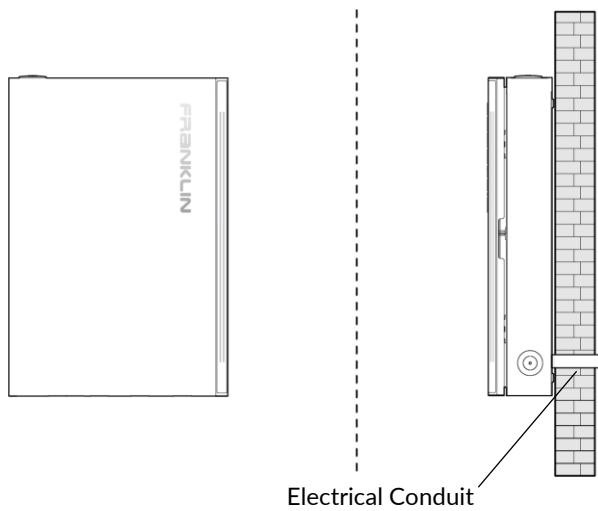

In this case, a conduit hub will be needed to ensure the IP grade of the aGate.

aPower knockout entries

The positions of the knockout entries on an aPower are shown below. The following scenarios offer variations on the cable entry points of an aPower to accommodate variations in the existing residential wiring layout.

The cable entry points on the wiring compartment of the aPower are 1.38 in. (35 mm) in diameter. The pull boxes have a 1" trade size.

Scenario 1: The electrical conduits and aPower share the same side of the wall.

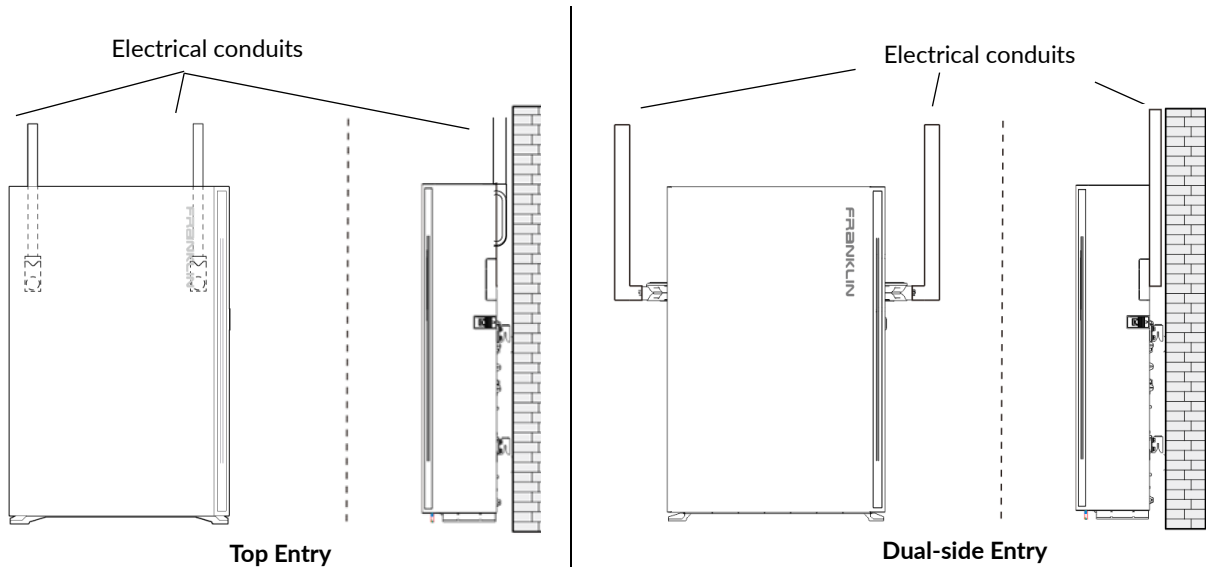

Determine the electrical conduit routing (top entry or dual-side entry) based on specific side conditions.

Gasketed pull boxes and sealing rings must be used to ensure the tightness of the wiring compartment.

Scenario 2: The cables will connect to the aPower from inside or through the electrical conduits through the wall.

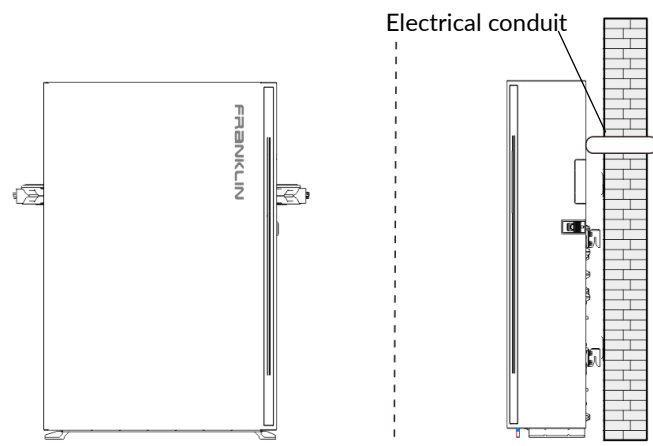

Sealing rings must be used.

A good seal must be guaranteed between the electrical conduits and the wiring compartment which can be achieved by using a conduit hub, sealing rings, or caulk.

3. Plan protection for aGate's input connections

The aGate serves as the entrance to the FranklinWH System. Lightning and over-current protection are recommended for all installations. A circuit breaker of 100 A to 200 A may be installed at the grid input connection and the generator input connection. Please refer to [Install breakers as needed](#) in this Guide for the recommended models of circuit breakers.

4. Plan the types, sizes and routes of cable and electrical conduits

- a) Please refer to [Wiring Requirements](#) for recommended cable types and wire diameters.
- b) As cables run through the electrical conduits:
 - The current-carrying capacity of the cables needs to be reduced. Please refer to the applicable information in Appendix B of NFPA 70.
 - The relationship between wire diameters, cable numbers, and inner diameters of conduits should be taken into consideration. Please refer to Appendix C of NFPA 70 for the list of maximum numbers of cables of the same size in the electrical conduits and pipelines.
- c) The type of electrical conduits depends on the installation type, indoor or outdoor:
 - IMC, EMT and other thin-wall metal conduits are recommended for indoor installations. These two types of conduits are cost effective, provide excellent anti-electromagnetic interference, and are easy to shape and to joint.
 - In outdoor installations, GRC and RMC thick-wall conduits are recommended because they can provide effective mechanical protection and good tightness at the conduit joints. Thick-wall conduits have a reduced flexibility disadvantage which makes bending and jointing very difficult.

5. Fire Code Compliance

The installation must comply with all applicable local codes, relevant regulations, and the requirements of local fire authorities.

6. FCC Requirements

See preface for the applicable FCC Requirements. The installer should inform customers of the contents in Appendix 2.

Tools Needed

- Personal Protection Equipment (PPE) (goggles, gloves, protective shoes, anti-dust respirator, etc.) for personal safety.
- Drill
 - ✓ Use 5/32" Brad Point bits or 5/32" Auger bits to drill pilot holes in wooden walls.
 - ✓ Use 1/2", 3/4", 1", 1-1/2", 2" sized wood bits to create holes in wooden walls.
 - ✓ Use 1/2", 3/4", 1", 1-1/2", 2" sized hole saw bits to create holes in metal walls.
- Hammer drill
 - ✓ Use 1/2", 3/8" Masonry bits to create pilot holes on concrete or brick walls.
 - ✓ Use 1/2", 3/4", 1", 1-1/2", 2" Diamond core bits to create holes in concrete or brick walls.
- Electric screwdriver, cross screw bits, and 3 mm Allen wrench screw bit to tighten the fastening screws.
- Torque wrench and bent-handle ratchet wrench.
 - ✓ 11/32", 5/16", 7/16", and 3/8" hex sockets, to tighten and check the torque of outer hex bolts.
 - ✓ 3/16" and 7/32" inner hex screwdriver bits to fasten cables at circuit breakers and pressure connectors and to check the torque.
 - ✓ 3/16", 1/4" straight screwdriver bits to fasten cables at circuit breakers and connectors and to check the torque.
 - ✓ PH2, PH3 cross screwdriver bits to fasten cables at circuit breakers and to check the torque.
 - ✓ 6" ratchet extension.
 - ✓ 1/4" open end interchangeable torque wrench to fasten relays and to check the torque.
- Flat head screwdriver (1/8" x 4", 1/4" x 4") to fasten signal terminals.
- Phillips head screwdrivers (PH#2 x 4", PH #3 x 4") to tighten fasteners.
- Claw hammer to break knockout holes.
- Utility knife to cut open boxes.
- Needle nose, vise grip, wire stripper, wire cutter, utility wire shear, and other cable preparation tools.
- Wire crimper, network cable testers, wire tracker, and other network cable preparation tools.
- Induction electro probe to detect the cables in walls to avoid short circuits when drilling.
- Multimeter to measure voltage, current and other electric parameters.
- Loop resistance tester to measure the wiring resistance and to detect poor connection of cables.
- Task light to illuminate the area when power supply is off.
- Level to check whether the equipment is level and plumb.

- Measuring tape.
- Markers for drilling marks.
- Camera to record the installation process.
- Deep cut band saw to cut thin-wall steel conduit or PVC pipes.
- FranklinWH lifting dolly.
- Conduit bender to bend thin-wall steel conduits, with the head size depending on the types and sizes of conduits, with $\Phi 1/2"$, $3/4"$, $1"$, $1-1/2"$, $1-1/4"$, $2"$ benders.
- Knockout tool kit to drill holes for conduits on the distribution box case.
- Adjustable wrench, size: 0-1.97 in. (0-50 mm).
- 6", 10", 18" pipe wrenches.

Torque Requirements

Screw type	Cross head screwdriver	Tightening torque
M4	PH2	1.03 lb·ft (1.4 N·m)
M5	PH2	2.21 lb·ft (3.0 N·m)
M6	PH3	4.42 lb·ft (6.0 N·m)
M8	PH3	8.85 lb·ft (12.0 N·m)

Items Provided by Installers



1	Electrical conduit, conduit hub, pull box and fittings
2	Screws and M6/M8 spacers for wall installation
3	aPower combiner box (for parallel operation of multiple aPower units)
4	5/8 in. Type X plasterboard
5	Copper or aluminum cables
6	Circuit breakers. For details, refer to the circuit breaker and optional parts section for circuit breaker models
7	Reducing washer conduit fittings
8	Network cable and registered jacks
9	Antioxidant conductive paste
10	Sealant (for use on outdoor conduits)

Unboxing

Unbox the aGate

- 1) Inspect the package for damage, scratches or dents.

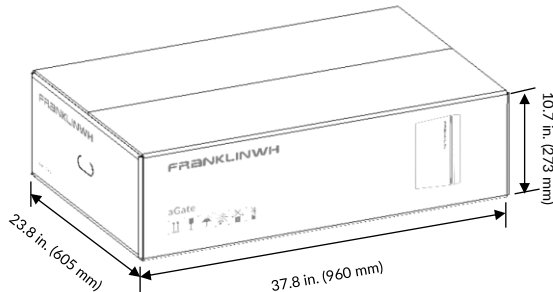

- 2) Adjust the utility knife blade to less than 0.3 in. (7.62 mm) as it may damage the aGate if too long. Cut the adhesive tape on the upper surface of the aGate box.
- 3) Open the aGate box, take out the template guide board and accessories, and then take the aGate out of the box.
- 4) Check that you have the following:



1	2	3	4
aGate	Switch tag	Grid relay reset handle toggle	1/4" water-tight washer
5	6	7	8
Cable ties	Main switch mounting screw M4 × 10	aPower breaker fastener	5m communications cable

- 5) Remove the packing foam from both sides of the aGate and remove the PE bag.

Unbox the aPower

- 1) Inspect the package for damage such as dents or scratches.

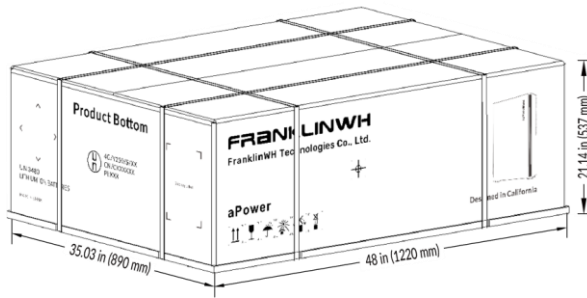

- 2) Cut the sealing tape and lift the cardboard cover.
- 3) Remove the protective box and top foam.
- 4) Check that you have the following:

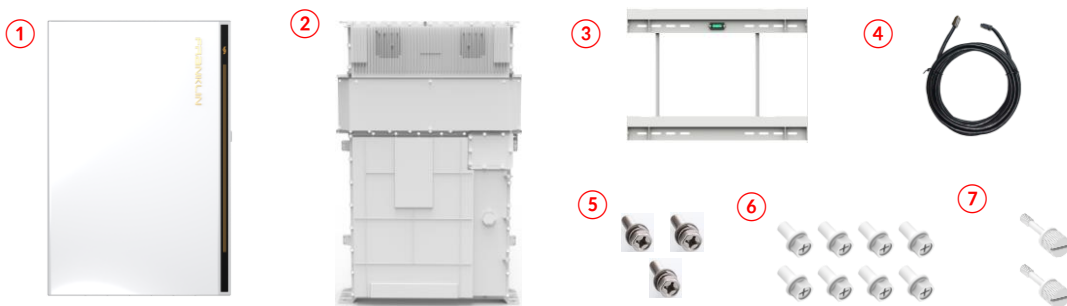

1	2	3	4
Cover	aPower chassis	Mounting bracket	6.5 ft (2 m) communications cable
5	6	7	
M 6 x 16 screws	M 5 x 12 screws	Captive screws	

- 5) Stand the aPower upright. Several installers should work together to prevent the equipment from falling.
- 6) Using FranklinWH lifting dolly, move the aPower to the installation site.



NOTE: Wrap the aPower in a protective blanket and keep the aPower well fastened to the dolly during transportation and handling to avoid scratches or damage.

Installation



DANGER: Care must be taken to protect personal safety. Reinforced toe shoes must be used to protect the installers in case equipment tilts or falls.



aGate Installation



WARNING: Add lightning protection measures per NFPA 780, UL96A, and LPI-175.

NOTE



- The drill template guide board will be used for drilling mounting holes. Keep it in good condition prior to use.
- The film wrapped around the aGate will be used to protect the internal components of the aGate when drilling mounting holes. Do not damage or dispose of the film until the drilling is complete.
- During the installation process, keep the aGate well protected from hard objects that may scratch the aGate surface and body.

Remove the aGate Door and Inner Panel

1) Remove the door

- Grasp the small notch on the right side of the aGate. Lift it slowly until the door of aGate is completely open.

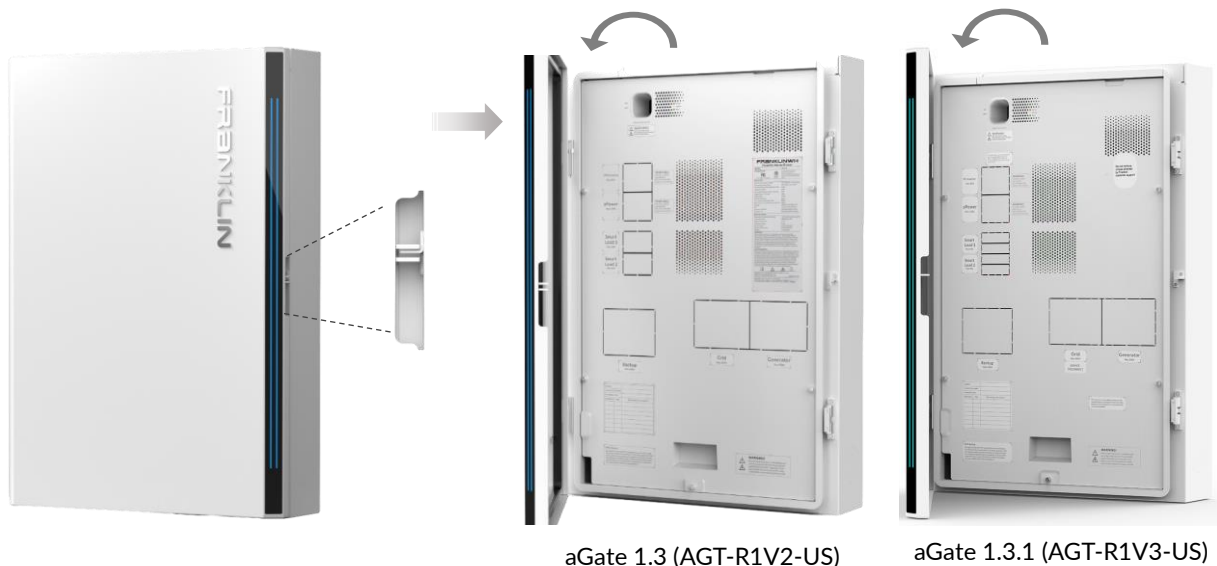

WARNING: The door may only be opened to a maximum of 100°, beyond which the door may be damaged.

- b) Gently lift the door panel upward, remove the aGate door after the hinges are separated, and properly store it.

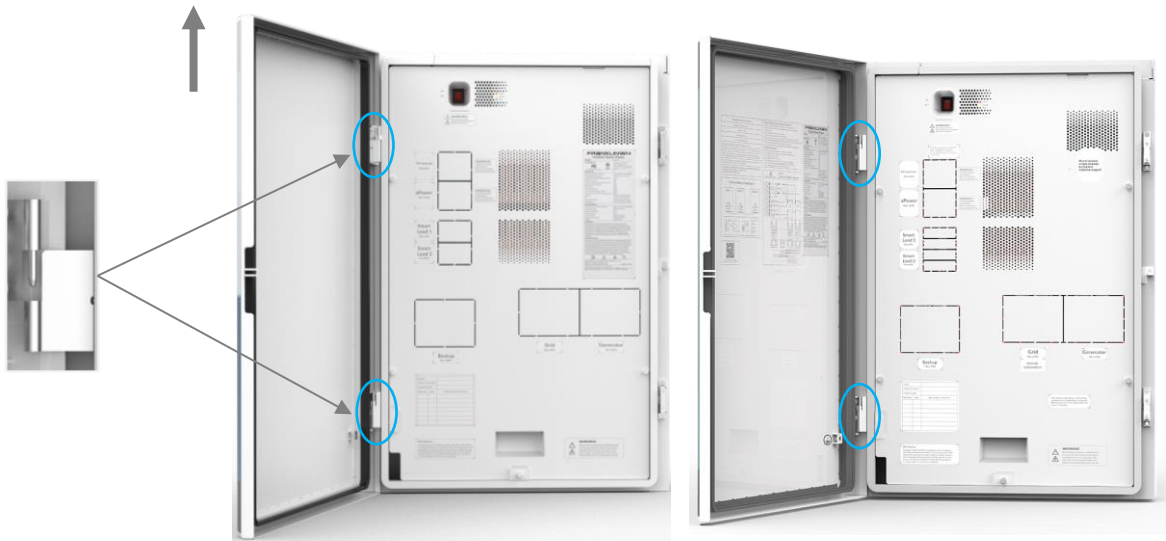

aGate 1.3 (AGT-R1V2-US)

aGate 1.3.1 (AGT-R1V3-US)

2) Remove the Inner Panel

Use a Phillips head screwdriver to loosen the 5 captive screws, counterclockwise. Remove the screws, and the aGate inner panel. Properly store the inner panel and screws for later use.

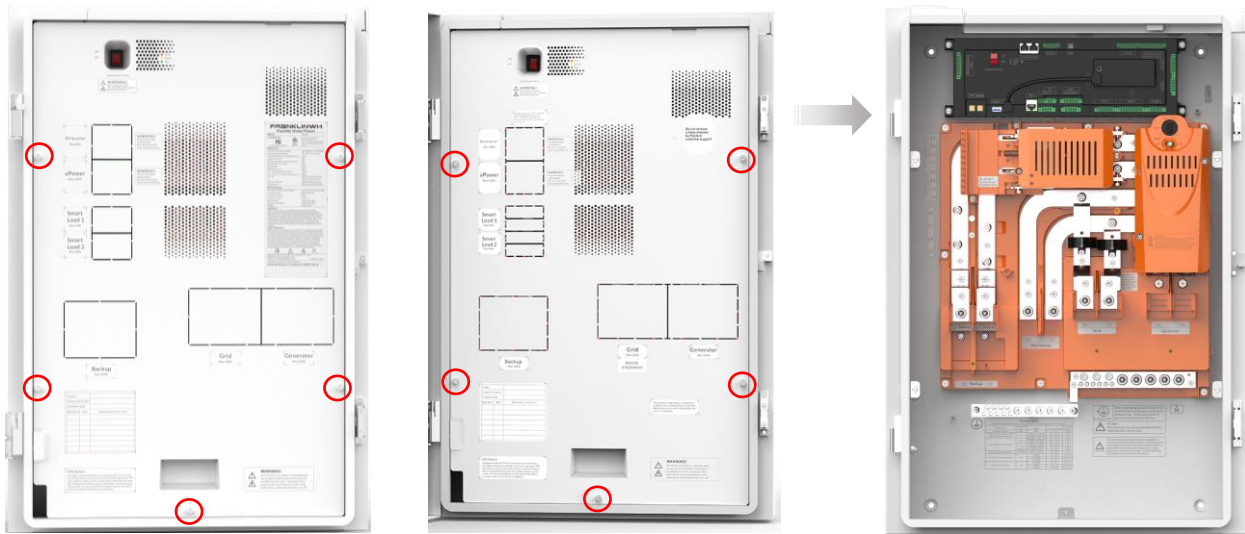

aGate 1.3 (AGT-R1V2-US)

aGate 1.3.1 (AGT-R1V3-US)

Prepare aGate Cable Entries

Based on the preplanned installation position and electrical conduit arrangement, remove the appropriate aGate plug or knockouts.

1) Remove the plug

The plugged hole on the top of the aGate enclosure is 2-15/32" (62.71 mm) in diameter. If the top cable entry is used, turn the plug nut counterclockwise by hand, until the nut is removed, then remove the plug.

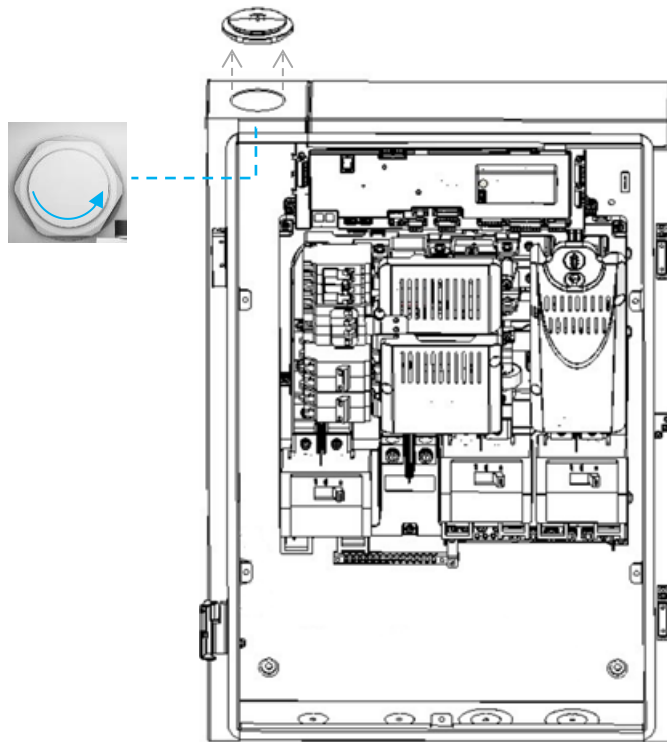

WARNING: It is recommended to install cables through the bottom of the aGate. If a top inlet cable is installed, waterproofing measures must be taken.

2) Remove the knockouts

All cable knockouts in the aGate enclosure are 1-23/64" (34.53 mm) in diameter with the two on the bottom right, and the one on the right side can be expanded to 2-15/32" (62.71 mm).

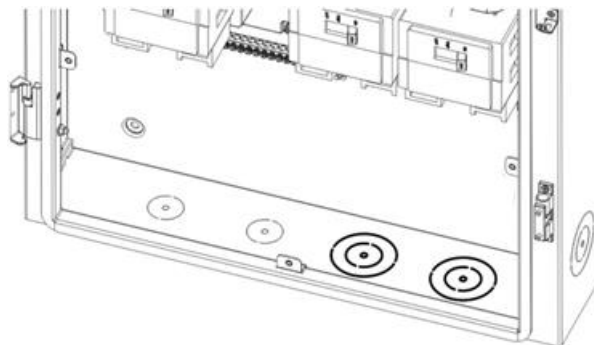

Drill out the necessary cable access holes from the aGate.

Enlarge or Drill New Holes (if necessary)

If the conduit diameter is larger than the aGate knockout hole, or if any new hole needs to be drilled, appropriate tools should be used to expand the hole or to drill new holes.



WARNING: To avoid damage to equipment, shield all aGate interior electrical boards and components before you drill or punch holes, to avoid debris falling into the aGate.

The aGate is shipped in a protective film. When enlarging or drilling new holes on the aGate, unwrap the outer film and use it to protect the components inside the aGate. Keep the film in place while drilling and punching holes. Remove all dust and debris before unwrapping the aGate for mounting.

White film wrapped on delivery



Internal components protection



Mount the aGate on a Wall

Follow the procedures below to install the aGate on a wall.

- 1) Place the aGate guide board template at the planned installation position. Adjust the guide board to level and then make marks at the four holes on the guide board.
- 2) Using an appropriate drill bit, drill holes in the wall. Then mount the aGate enclosure vertically on the wall. The water-tight washers provided must be used when mounting the aGate.



DANGER: Avoid drilling holes in water pipes and cables in the wall.



WARNING: Cover any nearby aPower top heat dissipation hole during drilling to protect from gravel dust.

See drilling details and the fasteners in the table below for more details on the hole depth and type of fasteners to use corresponding to different type of wall.

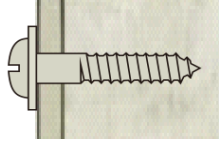
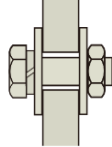
<p>Concrete or brick</p>	<p>Hole depth: Minimum 1-1/2" (38 mm) Fastener: 1/4" (6.35 mm) water-tight washer, spring washer, and nuts</p>	
<p>Wooden beams</p>	<p>Hole depth: Minimum 2.5" (64 mm) Fastener: 1/4" (6.35 mm) water-tight washer, wood screw with a large flat washer</p>	
<p>Steel beams</p>	<p>Hole depth: Through the steel beam Fastener: 1/4" (6.35 mm) water-tight washer, 1/4" (6.35 mm) stainless steel hex screws with spring washer and large flat washer and hex nuts</p>	

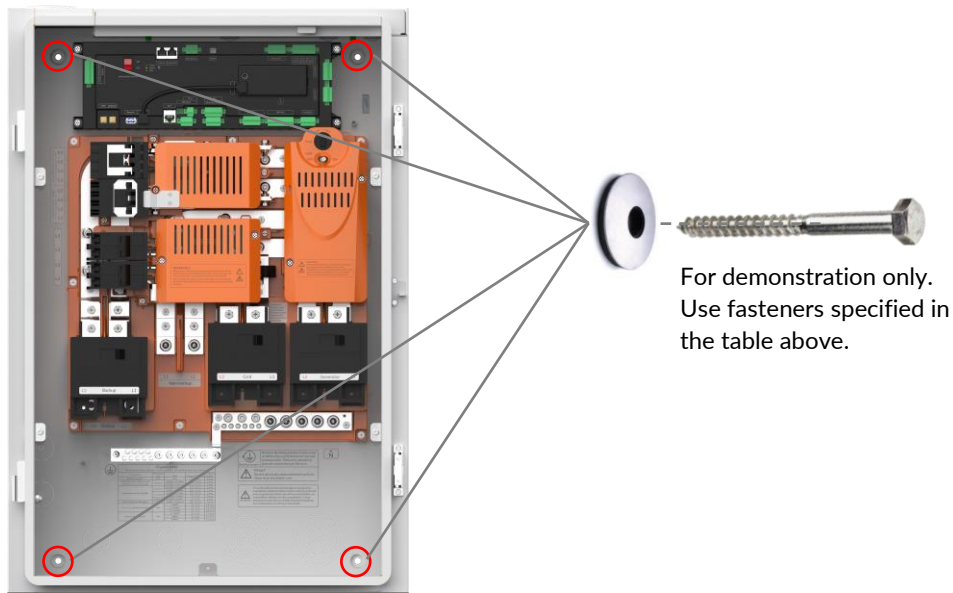

Install Optional Module(s)

FranklinWH provides optional the Smart Circuits Module, Generator Module, Main Load Relay, and Backup Expansion Lug Kit. For these modules' installations, refer to *FranklinWH Smart Circuits Module Installation Guide*, *FranklinWH Generator Module Installation Guide*, *FranklinWH Main Load Relay Installation Guide* and *FranklinWH Backup Expansion Lug Kit Installation Guide*.

Install Breakers as Needed

Install any needed breakers for PV, aPower, Smart Circuits, the backup panel, grid, and generator, according to local laws, regulations, standards, and National Electric Codes (NEC), ANSI/NFPA 70 or Canadian Standards Association CSA C22.1. These breakers are not included and must be ordered separately. Refer to [Appendix 1](#) for compatible breakers.

Breaker installation positions are noted in the image below:

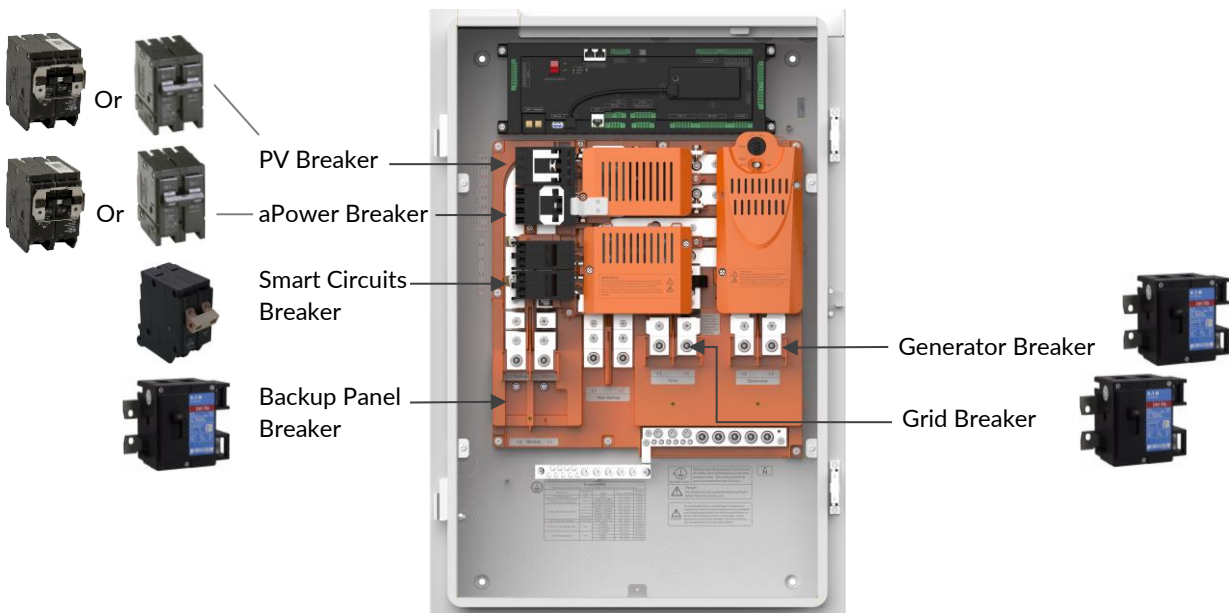

- 1) Before installation, make sure that the aGate is de-energized and the upstream and downstream switches are disconnected and locked out (LOTO) during installation.
- 2) Install the PV breaker, aPower breaker, and Smart Circuits breakers at the locations indicated in Figure 1.

aPower Breakers Options

Select the appropriate aPower breaker based on the desired power output.

Nominal Output Power (AC)*	Maximum Apparent Power	Maximum Continuous Current
5 kW	5 kVA	21 A
7.6 kW	7.6 kVA	32 A
9.6 kW	9.6 kVA	40 A
10 kW/11.5 kW	11.5 kVA	48 A

* The PCS derate feature applies to both charging and discharging rates.

- 3) Fasten the aPower breaker according to the following steps as per NEC requirements.

Install the breaker hold-down kit as shown in the diagram. Tighten the two M4x8 screws to the recommended torque using a Phillips screwdriver.

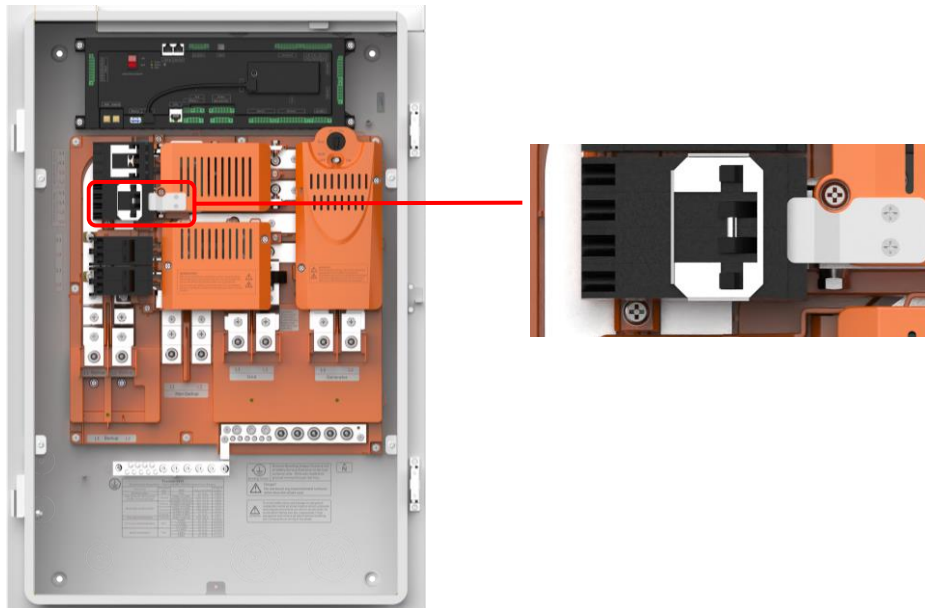

- 4) Before installing a backup panel breaker, a grid breaker or a generator breaker, remove the connected lugs. Follow the instructions below to remove the lugs and install the breakers:
 - a) Using a Phillips head screwdriver, remove the two M6 x 16 combination bolts holding the lugs and save it for later use. Remove the lugs.
 - b) Use the two M6 x 16 combination bolts to fix the breaker. Then use the M4 x 10 screw to secure the breaker. Using a Phillips head torque screwdriver, tighten the M4 screw to 1.03 lb·ft (1.4 N·m).
 - c) Attach the provided **L2 Backup L1**, **L2 Grid L1**, and **L2 Generator L1** labels below the backup panel breaker, the grid breaker, and generator breaker.

Remove the terminal lugs to install a backup panel breaker, a grid breaker, or a generator breaker.

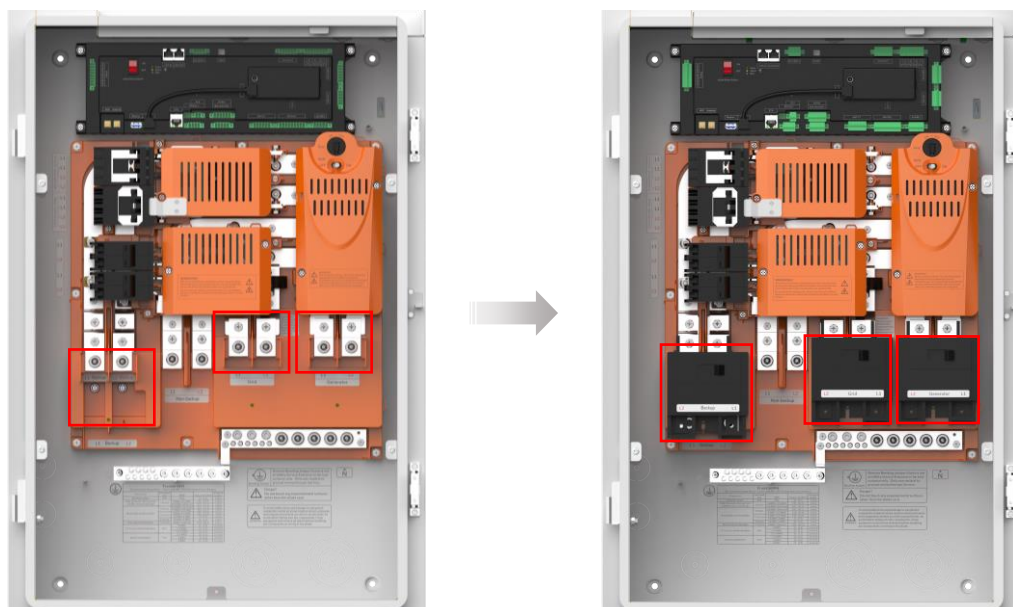



NOTE: The aGate's utility grid circuit breaker is only required where the aGate is used as service entrance equipment or there are no other circuit breakers protecting the conductors feeding the aGate's utility grid connection.

The generator breaker may be installed outside the aGate depending on site conditions.

aPower Installation

The aPower can be mounted either on the wall or on the floor. Choose a location that can structurally support the weight of the aPower.

Wall-Mounted Installation



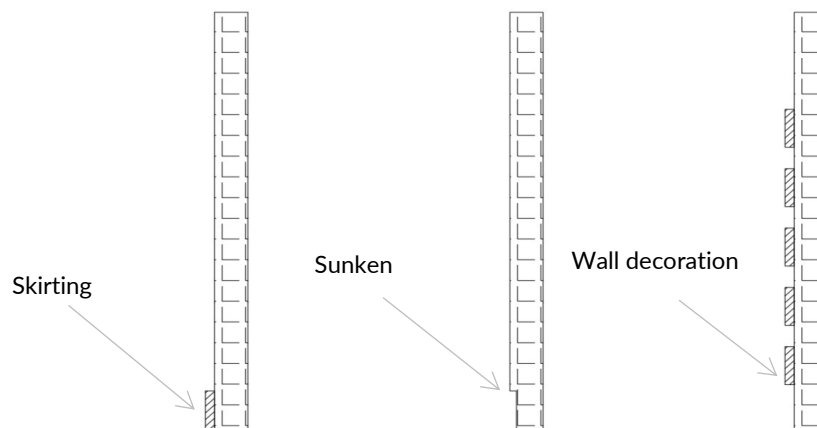

Install the mounting bracket

- 1) Before installing, examine the smoothness of the wall.

If the wall is not smooth and straight to the floor, Type X plasterboards will be needed to fill the gaps to ensure all parts of the mounting bracket are well supported by the wall.

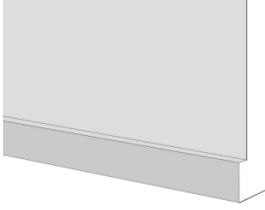
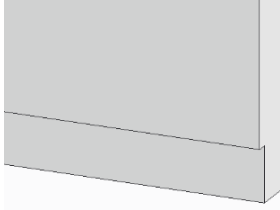
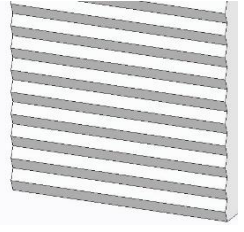

Special Wall/Baseboard Installation

<p>Case 1: Protruding Baseboard Height > 6 in. or the thickness of the bulge > 1 in.</p>	<p>Case 2: Concave Baseboard Height > 6 in.</p>	<p>Case 3: Uneven Wall</p>
		
<p>Solution Use wooden or steel spacers on the upper part of the bracket (to keep it flush with the baseboard).</p>	<p>Solution Use wooden or steel spacers on the indented part of the baseboard (to make it flush with the wall).</p>	<p>Solution Use plywood or gypsum board to level the wall. The recommended thickness is 0.5 in.</p>
		



NOTE: The wooden or steel materials are prepared by the installer.

2) Determine bracket attachment points

The mounting bracket should be fastened to the wall at a minimum of 4 points, one on each arm. If the mounting bracket is used to fully wall mount the aPower without ground support, be sure to use adequate fasteners to support the full weight of the aPower and mounting bracket. If necessary, consult a local licensed structural engineer for attachment guidance. Confirm compliance with all applicable local building codes.

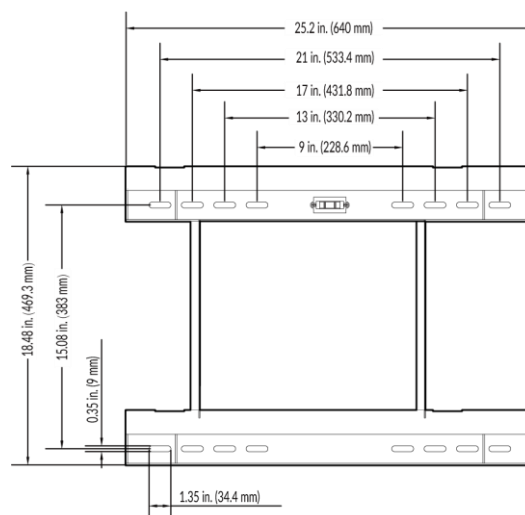

Determine bracket attachment points following the methods described below.

a) Method 1: Use the bracket to mark the points.

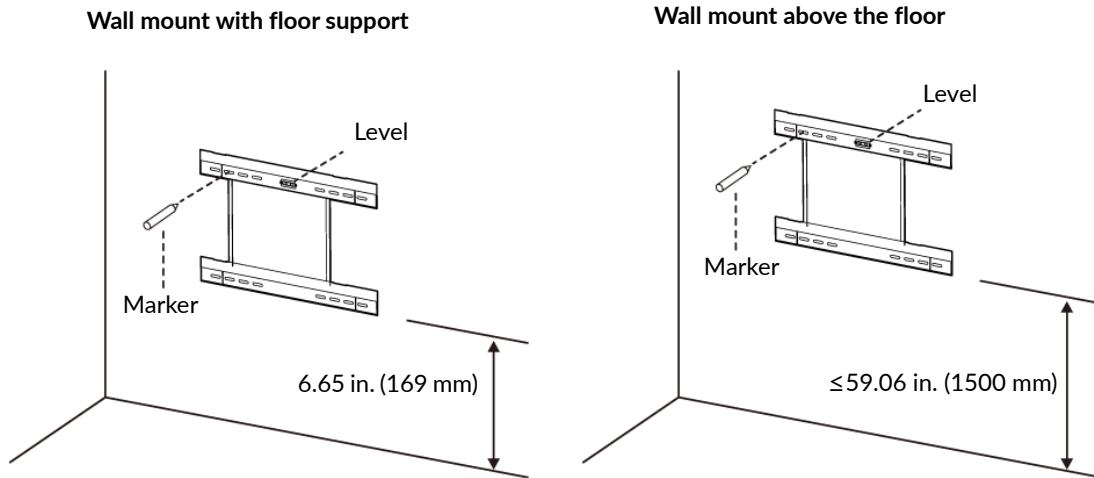

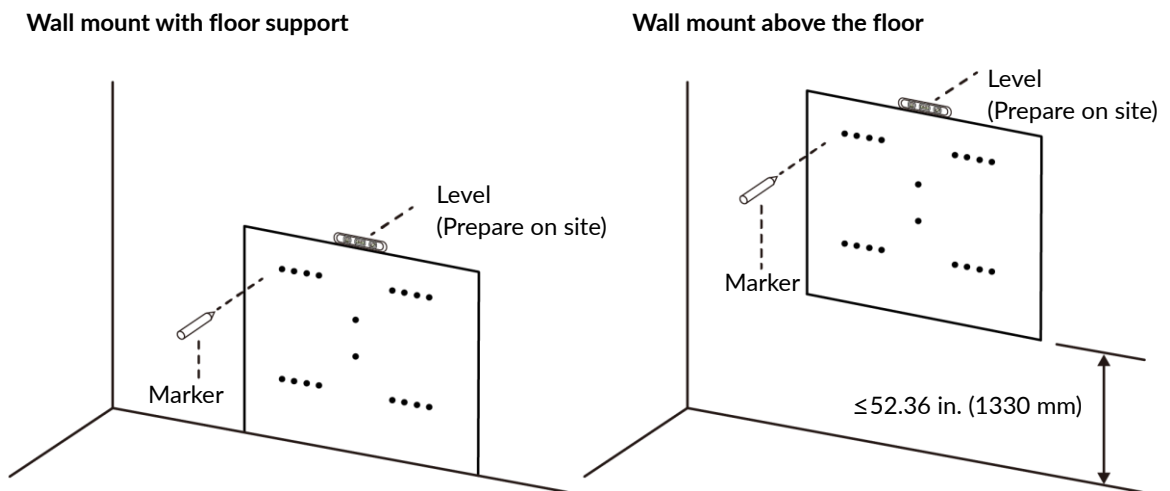

- ① Place the mounting bracket at the planned installation position.
- ② Mark the wall through the mounting holes where the fasteners will be used.

b) Method 2: Use the cardboard mounting template to mark the points.

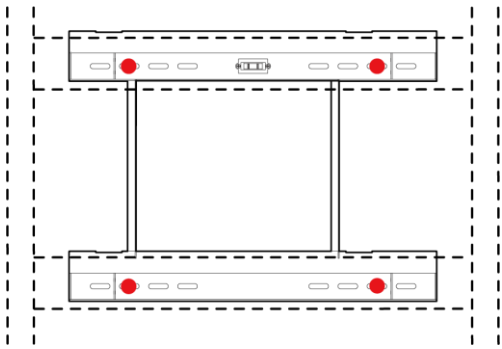
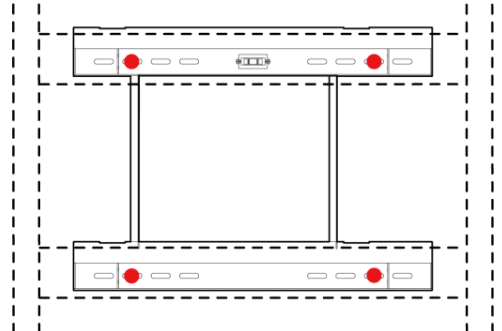

- ① Place it against the wall in the planned installation position according to the orientation of the cardboard text (the bottom of the cardboard is on the ground when it is installed on the ground).
- ② Use a level to adjust the installation angle.
- ③ Mark the wall through the mounting holes where the fasteners will be used.

3) Install the bracket on a wall

<p>Wooden beams</p> <p>At least 4 5/16" stainless steel wood screws with large flat washers (1 at each corner), at least 2.5" (64 mm) of each screw inserted into the wooden beam.</p>	
<p>Steel beams</p> <p>Use at least 4 5/16" stainless steel hex screws (1 at each corner) with spring washers, large flat washers and nuts to secure the bracket to the steel beam.</p>	
<p>Concrete or brick walls</p> <p>Use at least 4 5/16" stainless steel expansion screws (1 at each corner) with spring washers and large flat washers and at least 1.5" (38 mm) length embedded in the wall. Place screws at least 1.5" (38 mm) away from brick edge.</p>	

Drill conduit entry holes on the wall (if needed)

If needed, drill conduit entry holes on the wall. If there are any metal or wooden supporting structures in the drilling area, adjust the position to avoid them.



DANGER: Avoid drilling holes in water pipes and cables in the wall. PPE must be worn.



WARNING: Cover the aPower top heat dissipation hole to protect from gravel dust during drilling.

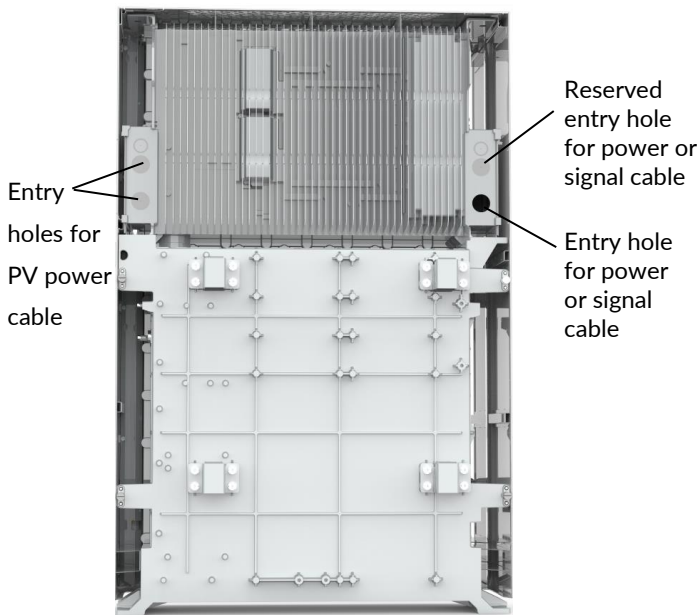

Rear View

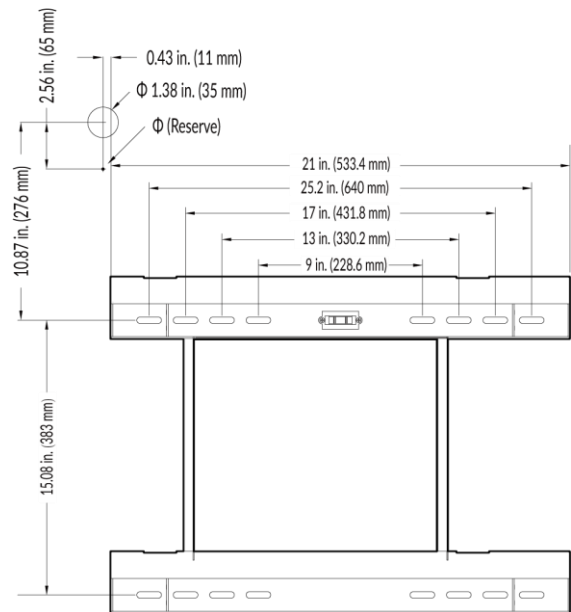

Front View: Bracket and conduit entry holes on the wall

	<p>Wooden wall</p> <p>Electric drill and 1", 1-1/2" wood bits are recommended to create holes for running cable through wooden walls.</p> <p>It is important that the drill bit be kept perpendicular to the wall when drilling.</p>
	<p>Concrete or brick wall</p> <p>Hammer drill and 1", 1-1/2" diamond tipped core bits are recommended to create holes for running cables through concrete or brick walls. Wet the wall and HEPA vacuum the dust, to protect the drill bits from overheating.</p> <p>It is important that the drill bit should be kept perpendicular to the wall when drilling.</p>

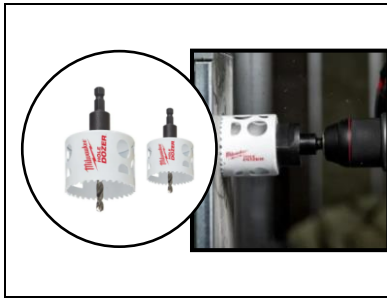

Metal wall or metallic studs

Electric drill and 1", 1-1/2" hole saw are recommended to create holes for running cables through metal plate and metallic studs.

It is important that the drill bit should be kept perpendicular to the installation surface when drilling.

Mount the aPower to the wall mounting bracket



DANGER: Special care must be taken to protect personal safety. Reinforced toe shoes must be used to protect the installers from tilting and falling equipment.



WARNING: Use proper protective measures on the lift, such as foam or protective cloth, and take effective protection measures to avoid scratching or damaging the aPower during the installation process.

- 1) For transportation, secure the aPower to the dolly using straps. Raise the aPower to position the rear mounting cleats slightly higher than the mounting bracket. Move the dolly so that the aPower is in mounting position. Slowly lower the aPower so that the four mounting cleats snap securely onto the mounting bracket.

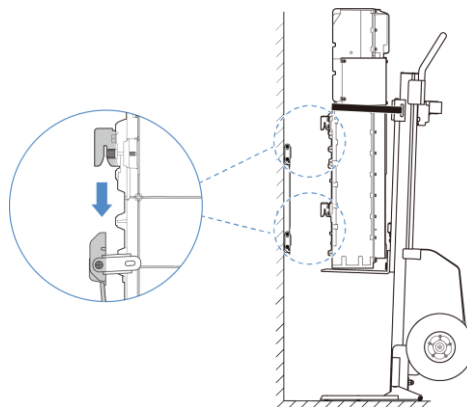

- 2) After the aPower is firmly seated on the mounting bracket, fasten the three retainer plates to the aPower using three M6 x 16 screws. Tighten to a torque of 4.3 lb·ft (5.8 N·m).

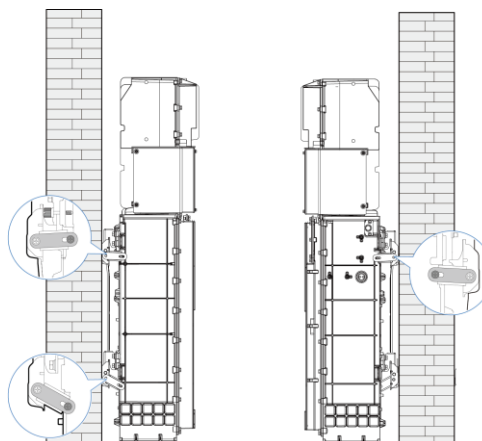

Free-Standing Floor-Mounted Installation using an optional Floor-Mounting Bracket

If wall mounting is not feasible, the optional floor mounting bracket (ACCY-FMBV2-US) can be used to install the aPower S on a concrete pad or a reinforced surface.

Installation site requirement

Perform a site assessment before installation. The poured concrete pads must have a minimum compressive strength of 3,000 PSI. And the concrete reinforcement must meet the temperature and shrinkage control requirements of ASTM A615 Grade 60, with a yield strength of 60,000 PSI.

Mount the aPower on a solid surface, such as a concrete floor, with an area exceeding 10.76 ft² (1 m²) and a minimum depth of 5.9 in. (150 mm). The aPower should be attached to a floor mounting bracket and maintain a minimum distance of 1.18 in. (30 mm) from the ground to the bottom of the aPower.

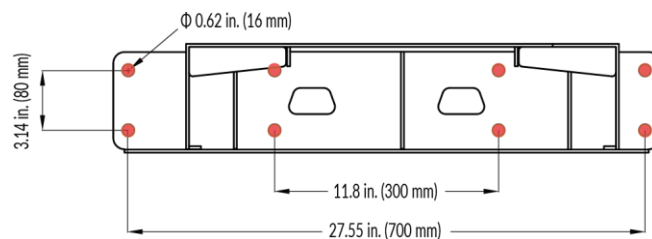

NOTE



The floor mounting bracket meets the strength requirements specified by IEC60721-3-3 recommended grade 3M4 sinusoidal vibration test conditions.

Install the floor mounting bracket

Choose a smooth, level concrete area with sufficient structural strength to support the weight of the aPower.

1. Mark eight mounting holes for drilling on the floor using the floor mounting bracket or cardboard mounting template as a guide.

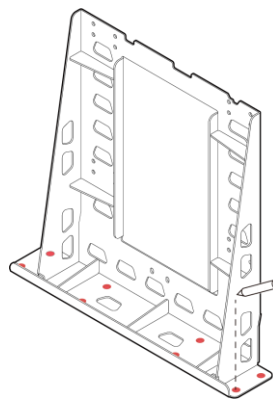

2. Drill holes at the marked spots.
The drilling depth should be at least 4.72 in. (120 mm), and diameter should be Φ 0.62 in. (16 mm).
3. Secure the floor mounting bracket to the floor with eight 1/2" expanding anchor bolts. Tighten the nuts to a torque of 73.8 lb·ft (100 N·m).

Mount the aPower to the floor mounting bracket

1. Remove the sixteen combination screws (M 8 x 16) and the four mounting cleats. Properly store the combination screws for later use.

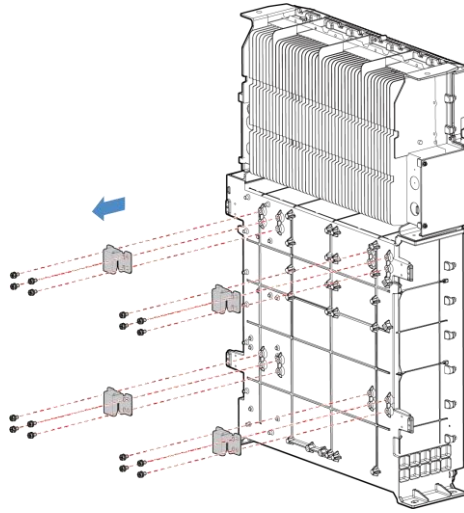

2. Hang the aPower on the floor mounting bracket and secure with the sixteen combination screws (M 8 x 16) that were previously removed and the two supplied M8 x 16 screws. Maintain a minimum distance of 1.18 in. (30 mm) from the ground to the bottom of the aPower.

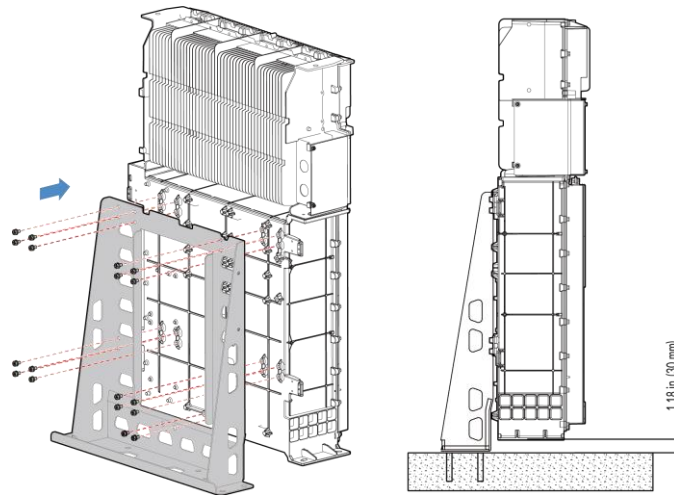

Install a Combiner Box (if needed)

The installation of more than two aPower units requires a combiner box. Each aPower should be connected to a 2-pole breaker. Select a suitable external combiner box and provide breakers for each aPower unit. For details, refer to [Install breakers as needed](#).



NOTE: Refer to the manufacturer's instructions before installation.

System Wiring

Install Electrical Conduit in the aPower

- 1) Remove the two M5 x 12 screws and the wiring compartment cover. Store the M5 x 12 screws and the wiring compartment cover properly.

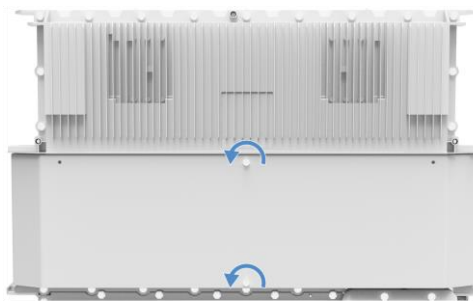

- 2) Flip the terminal lever to unplug the factory-installed power cables. Remove the communications cable. Use a 3 mm Allen wrench to loosen the terminal screw and disconnect the ground wire.

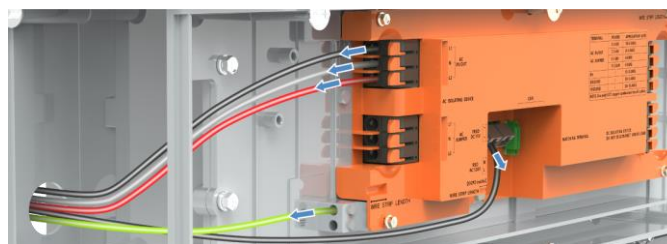

- 3) Based on the site conditions and wire gauge, select the appropriate knockouts on both left and right sides of the aPower S for cable wiring. Use a 1" hole saw and appropriate electrical tools to remove the necessary knockouts on the PV side.

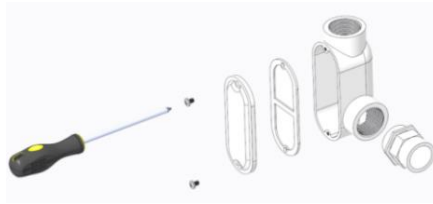

- 4) As needed, install pull boxes at the cable entry points.
 - a) Select appropriate waterproof pull boxes according to the cable distribution direction.
 - b) Use a Philips head screwdriver to disassemble the pull boxes.

**NOTE**

Ensure that the waterproof pull boxes are selected.

- c) Install the pull boxes on both sides.



- 5) Conduit Connection and Installation

Install conduit as needed and attach the conduit fitting to the cable entry of a Power wiring compartment.

The image below shows an example of conduit and fitting for different applications.

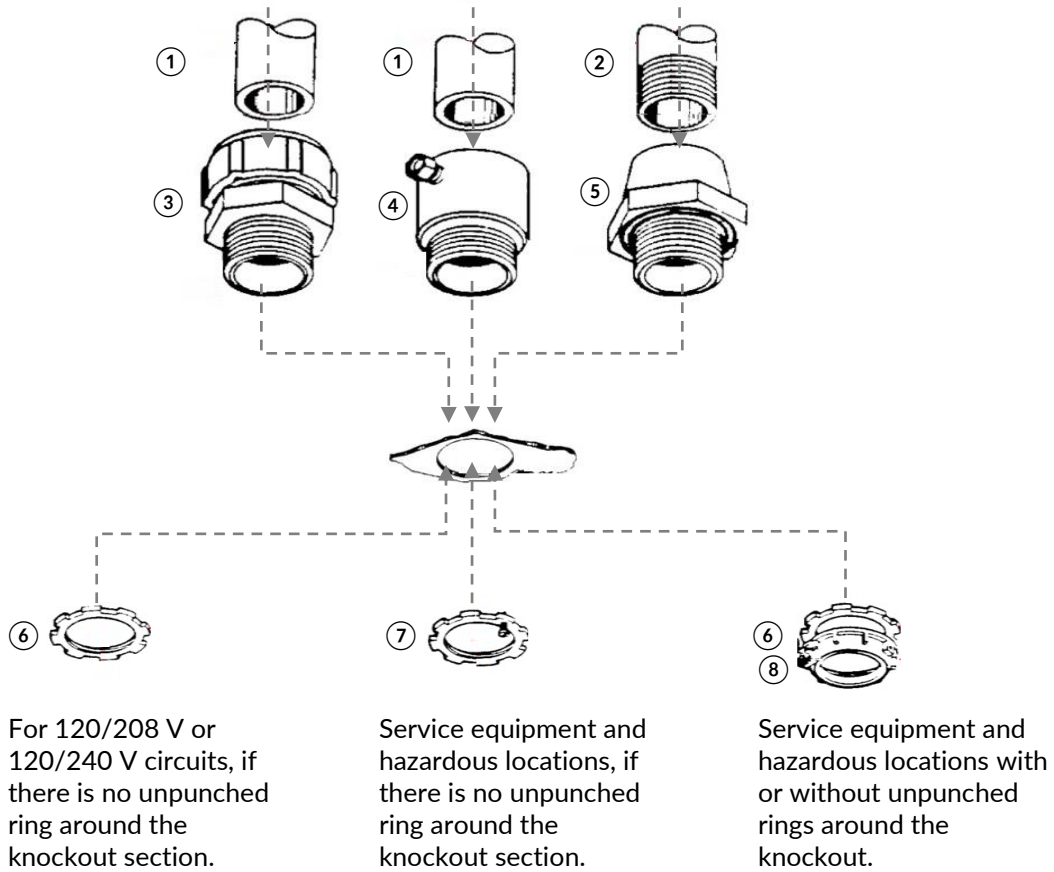

No.	Description
1	Threadless rigid metal conduit or intermediate metal conduit.
2	Threaded rigid metal conduit or intermediate metal conduit
3	Threadless fitting
4	Screw fitting
5	Sealing hub
6	Locknut
7	Bonding knockout
8	Bonding & grounding bushing



WARNING: The conduits and related materials must comply with UL746B requirements as well as all local laws and regulations.

Metallic conduits and fittings are recommended to minimize electromagnetic interference.

Prepare the Communications Wiring

Before wiring, ensure that the Com Kit (4G) cable is connected between the Com Kit port on the EMS module and the 4G module.

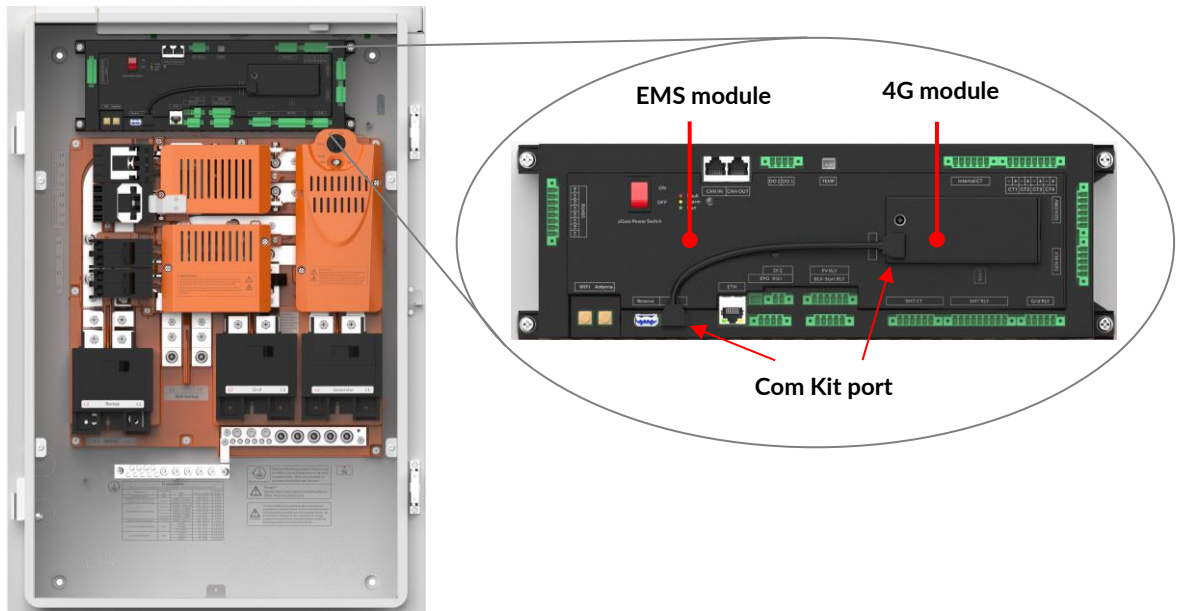

WARNING: Only use the cable supplied with the equipment. The aGate cannot be activated if this step is not completed.

Establish communications between the FranklinWH App and the aGate

- 1) Connect the mobile device to the aGate hotspot network to establish a local communications connection between the FranklinWH App and the aGate using the following account and password:

Account: AP_last 9 digits of serial number

Password: last 12 digits of serial number



NOTE: The account and password can be modified through the FranklinWH App.

- 2) Connect the aGate to the home internet network for remote access.
 - a) **Method 1 (Recommended): Connect the aGate to the home internet using a communications cable (Not provided).**

To ensure the reliability of remote communications, it is recommended to connect the home network cable with internet connection to the **ETH** port of EMS module.

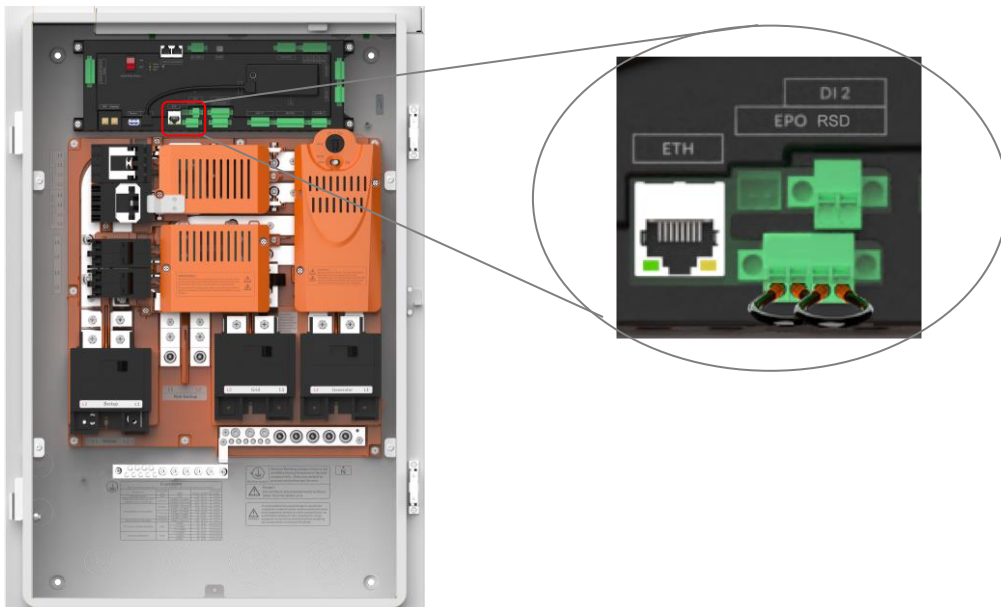

WARNING: The cable from the home network may only be connected to the ETH port.



The communications cable needs to be made on site using a crimping tool, a ready-made network cable should not be used because it may prevent the aGate internal cover from closing. Test with a network cable tester to ensure that the cable contact is error-free.

Communications cable preparation

- i. Remove the insulation jacket from the cable.
- ii. Fan the wires in the order of 568B (See wiring scheme diagram).
- iii. Insert the wires into the connector.
- iv. Crimp the connector using a crimping tool and then the cable is ready.
- v. Test with a network cable tester to ensure that the communications cable contact is error-free. Before testing the cable, ensure that both ends of the cable are disconnected from the FranklinWH System.



Wiring scheme

The communications cable wiring must conform to the 568B standard sequence.

- Pin 1: white/orange
- Pin 2: solid orange
- Pin 3: white/green
- Pin 4: solid blue
- Pin 5: white/blue
- Pin 6: solid green
- Pin 7: white/brown
- Pin 8: solid brown

RJ-45 Pin	1	2	3	4	5	6	7	8
Pair	2	2	3	1	1	3	4	4

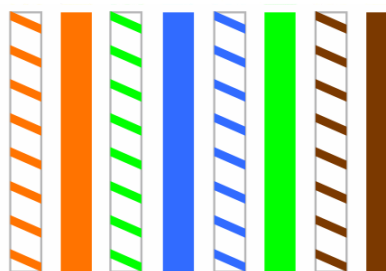

b) Method 2: Connect via Wifi

The Wifi connection between the aGate and home wireless network should be done during commissioning. Please refer to the *FranklinWH Commissioning Guide*.

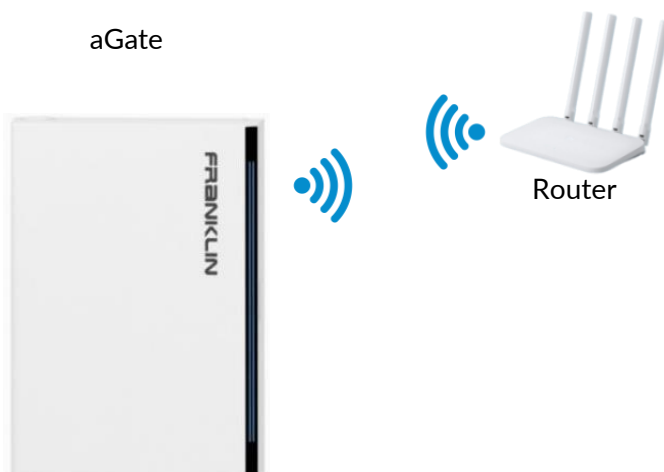

c) Method 3: Connect via 4G network (only as backup)

A SIM card is pre-installed on the wireless module. When you choose 4G network connection, make sure that there is a good 4G LTE signal in the local area.

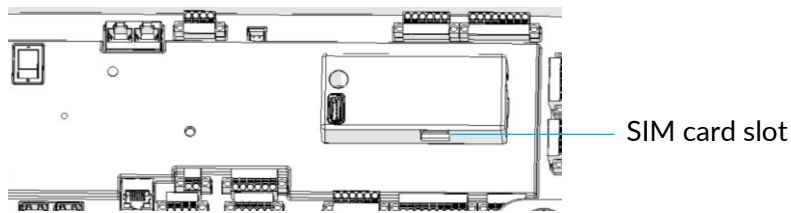

Establish communications between the aGate and the aPower



NOTE: It is recommended to install the communications cable in the conduit to avoid accidental damage and equipment failure. If the network cable and the power cable share the same conduit, use a shielded network cable (RJ45 cable end with metal connector).

Before connecting the communications cable, use a network cable tester to ensure that the cable contact is error-free.

The distance between the aGate and the first/single aPower must be ≤ 164 ft (50 m).

a) Communications connection between the aGate and a single aPower

Remove the dust plug from the aPower CAN port.

Use a minimum CAT5 cable to connect the aGate **CAN OUT** port to one of the aPower **CAN** ports.

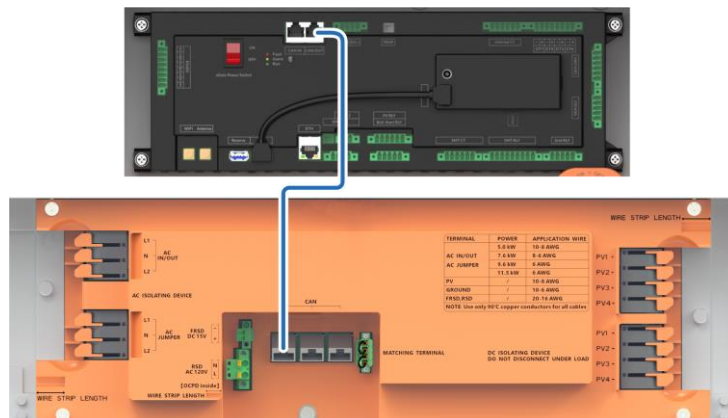

NOTE

The three CAN ports in the aPower S are interchangeable. Use any port as needed.

b) Communications connection between the aGate and multiple aPowers

Remove the dust plugs from the aPower CAN ports.

Use a minimum CAT5 network cable to connect the aGate **CAN OUT** port to one of the **CAN** ports of the first aPower. Connect the **CAN** ports on the remaining aPower units in sequence.

Remove the matching terminals from all aPower units except for the one in the **last** aPower.

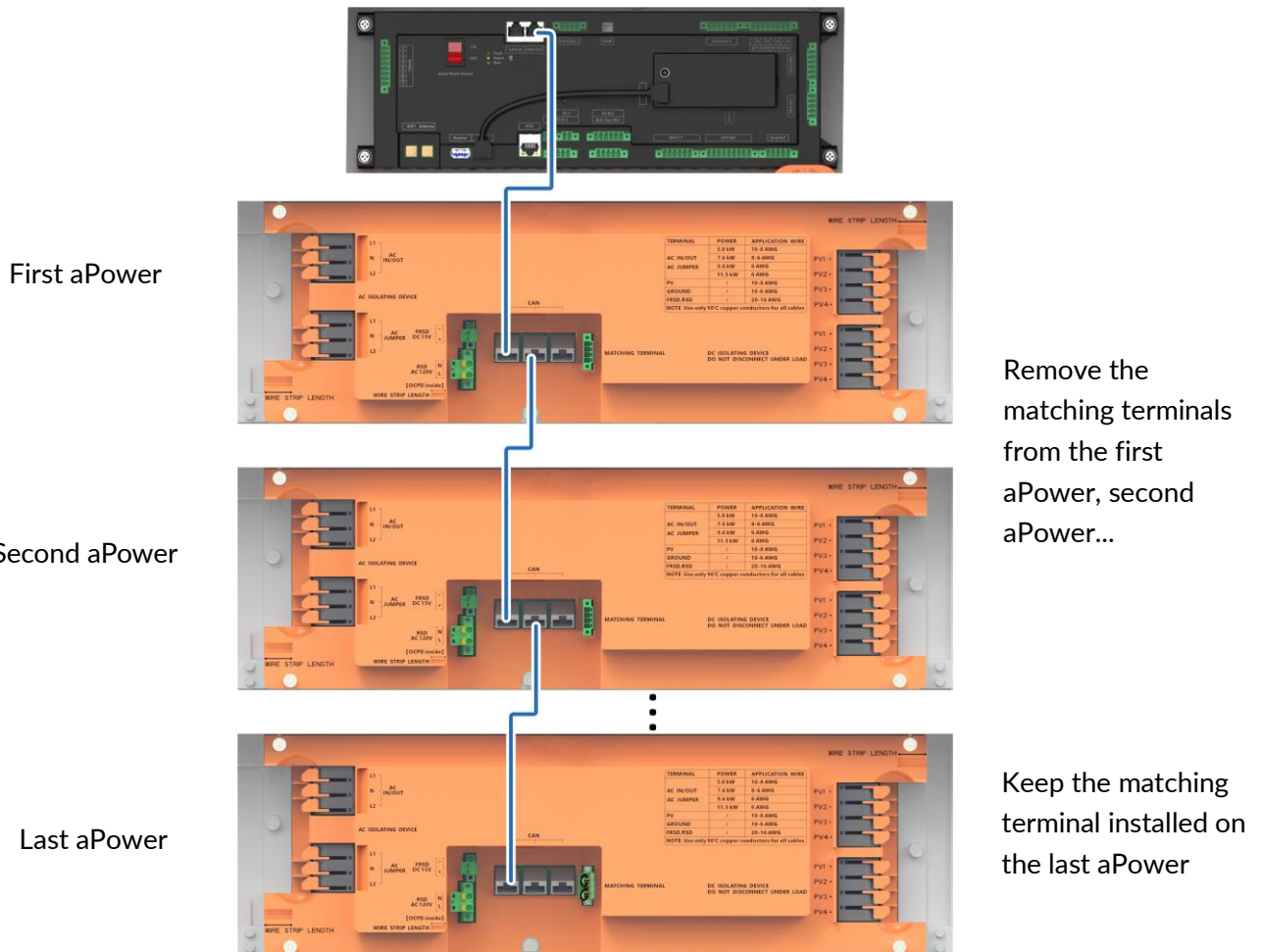

NOTE

The three CAN ports in the aPower S are interchangeable. Use any port as needed.

If the distance between the aGate and the first/single aPower exceeds 164 ft (50 m), please contact engineering@franklinwh.com for guidance.

Run Electrical Wiring in the aGate



NOTE: The wiring of breakers should follow the specific breaker instructions. The power sources must be connected to the aGate at the corresponding ports.

The cable conductor size and current capacity rating are listed in the NFPA 70, Article 310.

Conductors, relied upon for the protective grounding and bonding system, will be sized to handle the intended fault currents and, if insulated, the insulation will be green or green with yellow stripes.

Grounding conductors are sized following NFPA 70 Article 250.122 of or C22.1 Rule 10-810.

A field wiring terminal or lead shall be rated for the connection of a conductor or conductors having a minimum carrying capacity rating of 125% of the rating of the unit.

The distance between the end of the connection point of a field-installed wire and the wall of the enclosure toward which the wire is to be directed, shall be following NFPA 70 Table 312.6 (A) or (B).

Please be sure to apply antioxidants to any aluminum cable stripped surfaces.

Cables selection will consider metal compatibility. Please refer to Figure F.1 in Appendix F for the UL9540 standard.

	<p>DANGER: Please follow the Local Precedence rule. Remote control does not mean that the local circuits are safe. Please decide whether your circuit is safe based only on a circuit test.</p>
	<p>DANGER: The power cables should be wired in a sequence of the load side, the backup power supply side, and the non-backup power supply side. If the other end of a cable cannot be wired at the same time, a warning sign Out of Operation, Do NOT Turn On should be hung.</p>
	<p>DANGER: aGate and aPower units do not have any indoor-level lightning protection. Customers should configure lightning protection equipment where the grid power runs into the house.</p>
	<p>DANGER: Electrical connections require that the wires are connected in the correct order, where L1 and L2 cannot be misconnected. Incorrect wiring may cause equipment damage or even personal injury or death.</p>

Connect the PV inverter to the aGate

When connecting AC coupled PV to the aGate in addition to the PV landed on aPower S, the PV breaker is the only interface to be used. Do not connect the PV inverter to any other port.

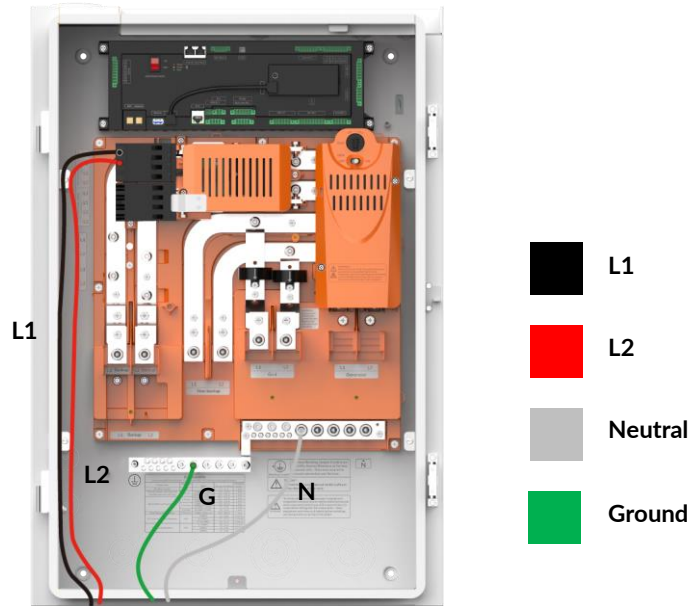

Connect the backup panel to the aGate

Connect the backup panel conductors to the aGate terminals. Refer to [Wiring Requirements](#) for recommended cables.

After installation of the backup panel breaker, L1 and L2 will swap sides for connections (L2 is located to the left while L1 is to the right).

Without a backup panel breaker

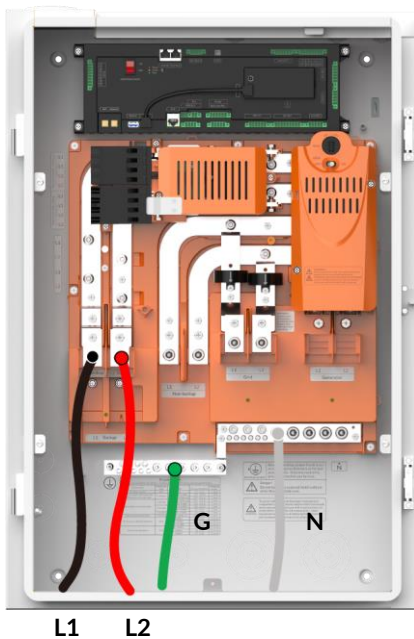

With a backup panel breaker

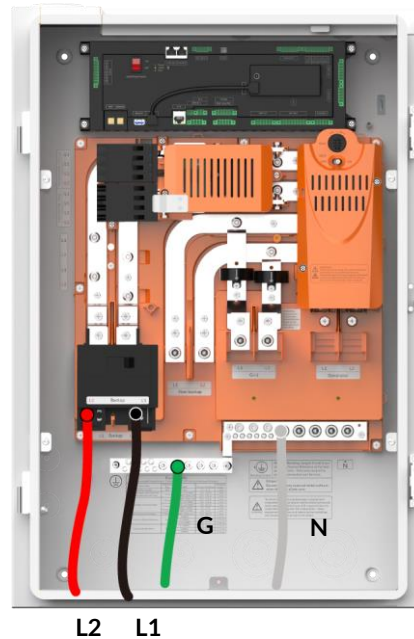

Connect the grid supply to the aGate

Connect the grid supply conductors to the aGate terminals. Refer to [Wiring Requirements](#) for recommended cables.

After installation of the grid breaker, L1 and L2 will swap sides for connections (L2 is located to the left while L1 is to the right).

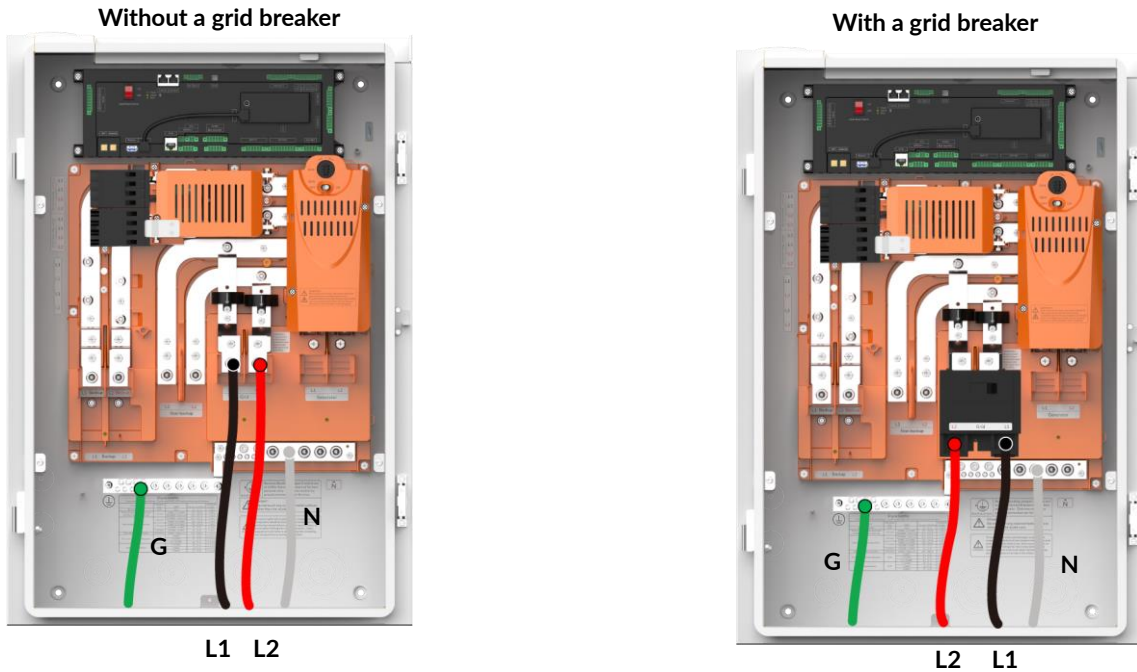

According to NFPA 70 250 Grounding and Bonding Part V, when installed as service equipment, Ensure the panel's main breaker is appropriately labeled as "SERVICE DISCONNECT," the neutral and ground should be bonded together, as shown in the figure below.

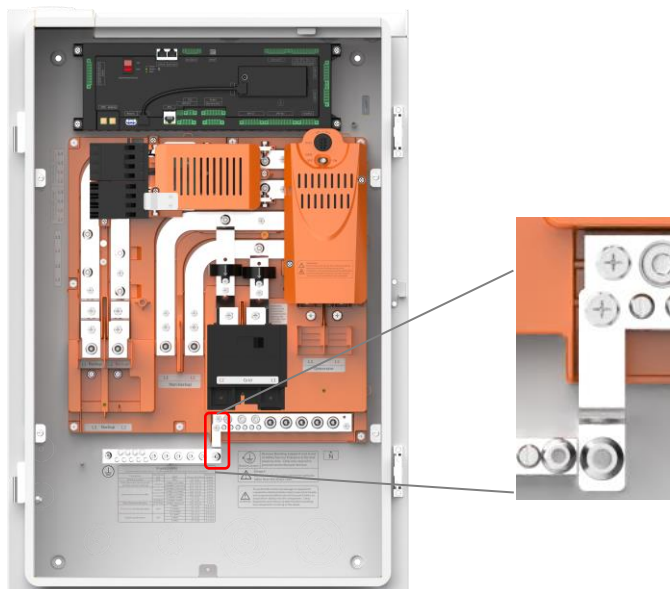

The Neutral-Ground Bonding Jumper must only be removed if not installed as Service Equipment, or for test purposes.

A torque wrench with 11/32" hex sockets will be needed to remove or install the bonding jumpers.

For installation, the required torque is 26.55 lb·in. (3 N·m).



WARNING: To ensure safe operation in Backup Mode, the aGate must have a local ground connection, such as through a ground rod or ground electrode. The connection of the ground rod must comply with local codes and regulations.

Establish the PV Power Connection

To comply with NEC Article 690.12 and ensure rapid disconnection from photovoltaic panels in emergency situations, it is required to install a rapid shutdown device (RSD) on each photovoltaic panel within the string.

The aPower S has been tested and listed as the most common RSD products on the market. The installer must prepare the third-party RSD systems, following the manufacturer’s instructions for installation of rooftop receiver and ground level transmitter equipment. The aPower S can also be installed without RSD provided local codes and jurisdiction allow it.

Products and models compatible and listed with FranklinWH

Product	Rooftop Receiver	Transmitter	Outdoor Kit
APsmart	RSD-S-PLC RSD-D-20	Transmitter-PLC-1P	Transmitter-PLC-Outdoor Kit APS-408006/APS-408012
Tigo	TS4-A-F TS4-A-2F	RSS Transmitter	Tigo 492-00000-51

Voltage Configuration for RSS Transmitter Outdoor Kit

The RSD PWR terminals on the aPower S provide an output voltage of either 240 V or 120 V AC, as indicated by the silkscreen text on the Control Board Cover of the aPower S. It is recommended to select an RSS power supply that can accommodate a 120 V or 240 V AC input range and convert it to the 12 V DC required by the transmitters.

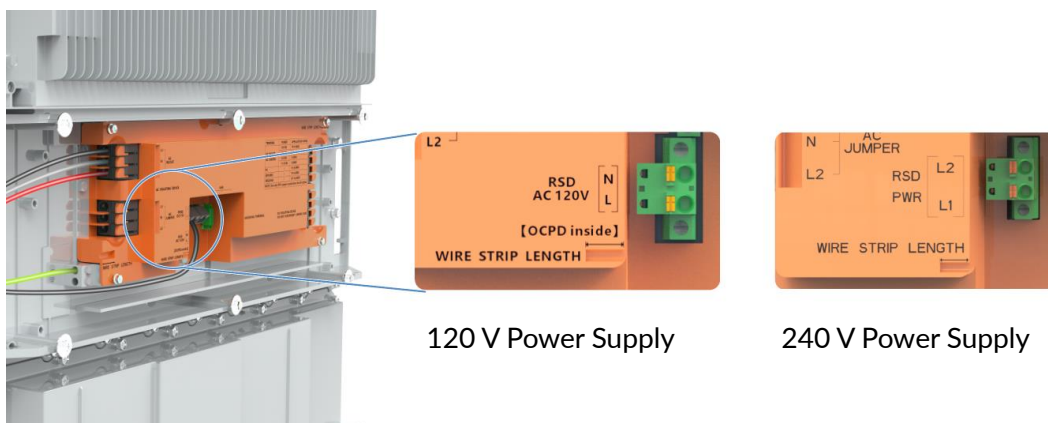

The number of RSS transmitter outdoor kits purchased by the installer must match the number of aPower units installed. Each RSS transmitter outdoor kit must be paired with its own aPower.

Install the RSS transmitter outdoor kit and RSD module

- 1) Prepare and waterproof the junction box as per manufacturer's requirements.



NOTE: The installer shall confirm: (1) the RSS power supply is prepared on site, (2) it accepts 120 V or 240 Vac input, and (3) it outputs 12 Vdc that matches the transmitter's requirement.

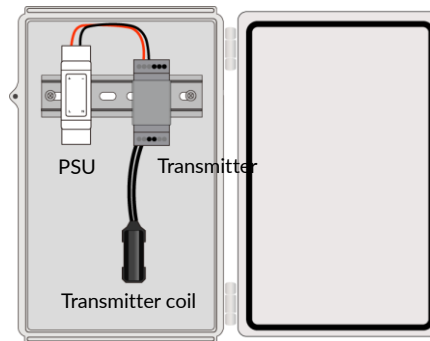

- 2) Securely mount the whole RSS transmitter outdoor kit near the aPower S. Ensure the installation distance from the RSD modules complies with the RSD manufacturer's instructions.



- 3) Install RSD modules on PV panels referring to the relevant manufacturer's instructions.

Based on the electrical characteristics of the homeowner's PV array, connect the RSD modules in series as per the detailed specifications outlined in [Appendix 2 Solar Terminal](#).

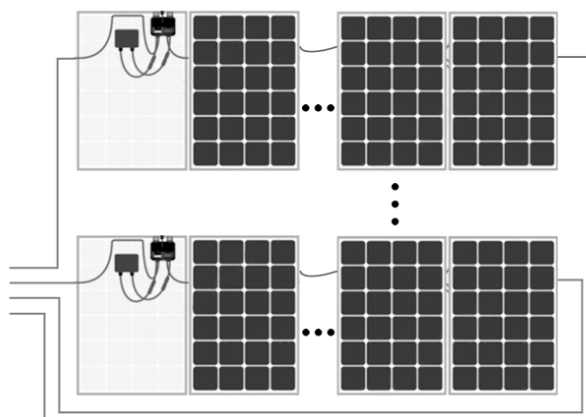



WARNING

To ensure the stability of the power supply, install the junction box near the aPower.

Connect the RSS transmitter outdoor kit and PV Cables to the aPower S

Cable Requirements

Comply with the cable specifications in the table below. Improper cabling can lead to equipment damage or fire risks.

Cable Type	Specification	Strip Length
RSD Power Cable	20-16 AWG, 90° C rated	0.39-0.43 in. (10-11 mm)
PV cable	10-8 AWG, 90° C rated	0.73-0.76 in. (18.5-19.3 mm)
PV ground cable	10-8 AWG	0.73-0.76 in. (18.5-19.3 mm)

NOTE



Use the small groove next to the **RSD PWR** terminal to measure the correct strip length of the RSD power cables.

Use the large groove on the top-right side of the control board cover to measure the correct strip length of the PV power cables.

Wiring Steps on PV side

- 1) Connect the RSD power cables to the aPower **RSD** terminals (L&N or L1&L2) and the AC conductors (L&N) of the power supply in the RSS transmitter-outdoor kit.

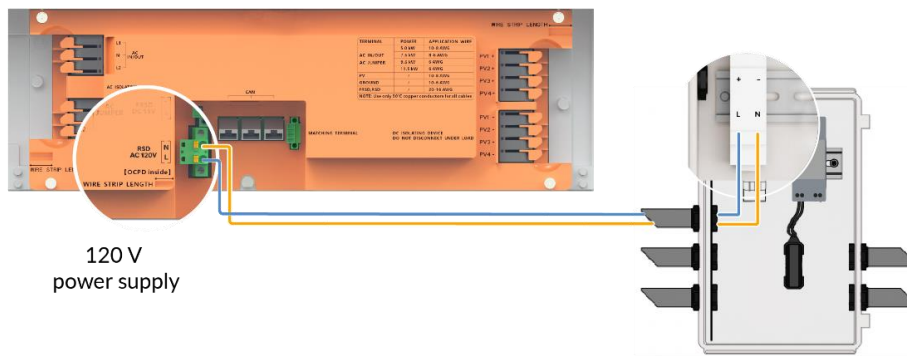

120 V power supply

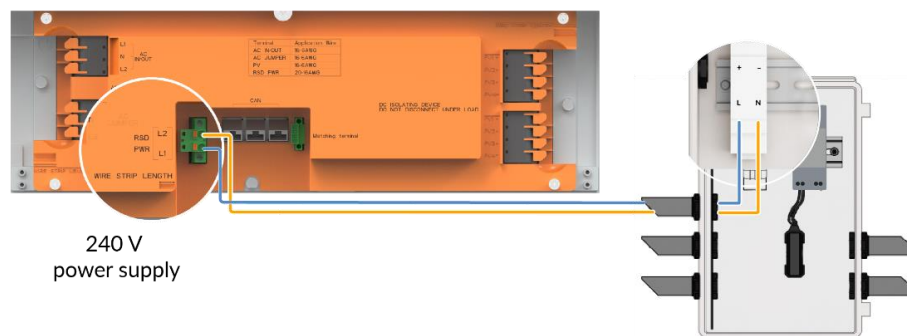

240 V power supply

- 2) Route all the PV power cables through the RSS transmitter-outdoor kit. Pass the four positive PV power cables through transmitter core per manufacturer’s instructions.

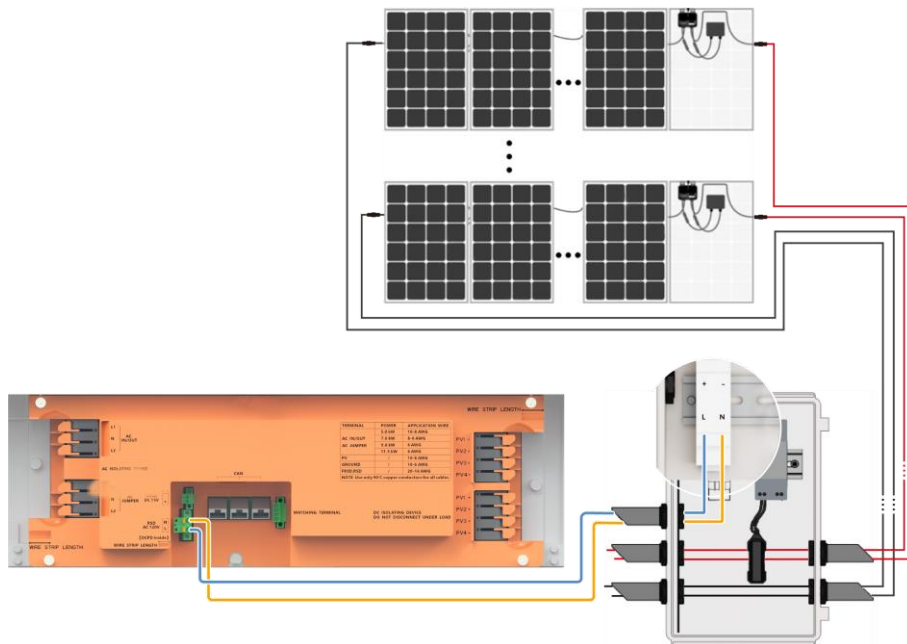

- 3) Strip the PV power cables and PV ground cable, then land the stripped ends on their respective terminals (PV+/- and PV GND).
 - a) Measure the wire strip length using either the groove on the control board cover’ corner or a dedicated wire stripping tool.



- b) Strip the wire insulation to 0.73-0.76 inches (18.5 to 19.3 mm).

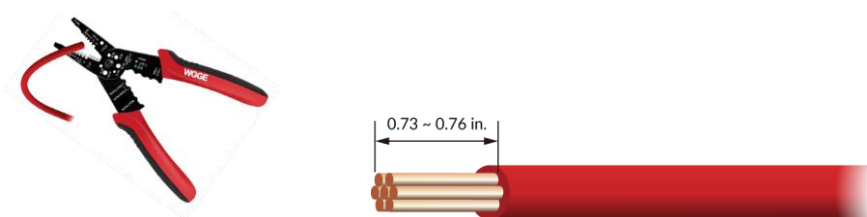

- c) Pass the PV power cable through the pull box. Lift the terminal levers to the fully open position and insert the wire until it reaches the bottom of the terminal.

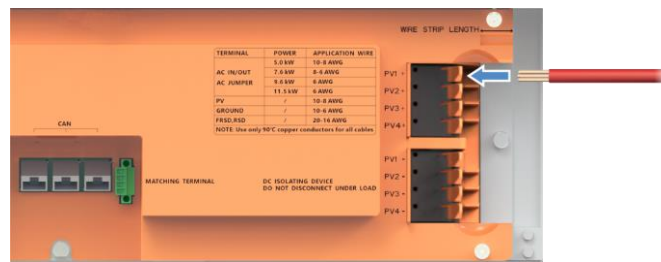

- d) Firmly press down the terminal levers. And perform a pull test to confirm the secure connections.

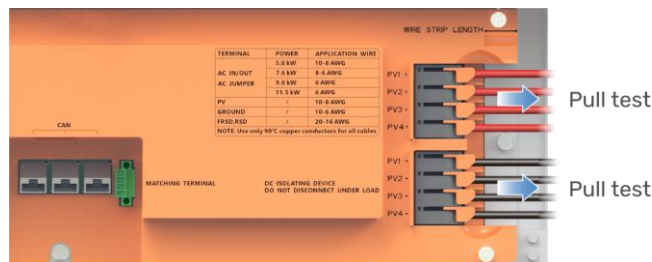

- e) Route the PV ground cable through the pull box, then use a 3 mm hex wrench to secure it to the PV GND terminal.

For multiple aPower S units installed, the installer shall prepare a corresponding number of RSS transmitter outdoor kits. Each aPower S must be paired with its own RSS transmitter-outdoor kit.

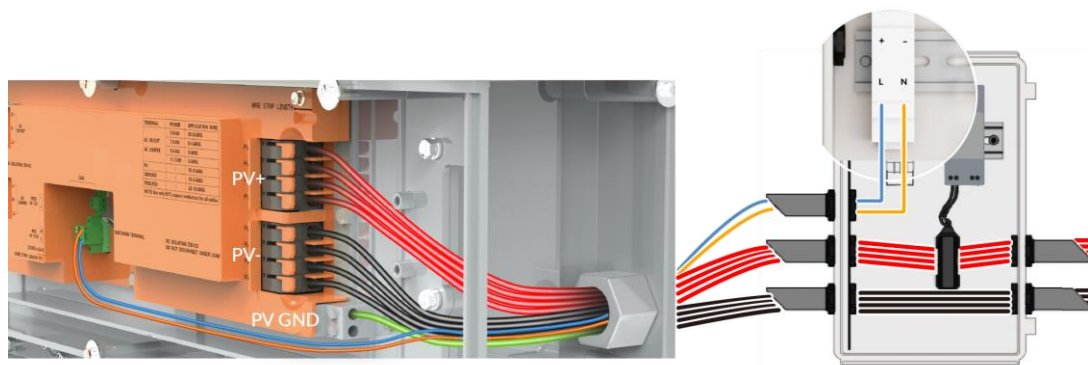

WARNING: Correct polarity must be followed.



Refer to the embossed symbols (PV+/PV-) next to the PV terminals, connect the positive PV power cables to the upper (+) terminals and connect the negative PV power cables to the lower (-) terminals.

Connect the aPower(s) to the aGate

Cable Requirements

For all aPower connections, use only copper conductors rated for 194° F (90° C). Choose power cables in the 10 AWG to 6 AWG range based on the aPower's rated power specified in the utility contract. Installers should select the appropriate wire gauge according to the AC power requirements. Refer to the table below for compliant cable specifications.

Terminal	Rated Power	Wire Gauge
AC IN/OUT	5 kW	10-8 AWG
	7.6 kW	
AC JUMPER	7.6 kW	8-6 AWG
	> 9.6 kW	6 AWG

Strip Length Specifications

- **aPower AC terminals/GND terminal:** 0.73-0.76 inches (18.5 to 19.3 mm)

You can use the large groove on the corner of the aPower orange control board cover to measure the wire strip length.

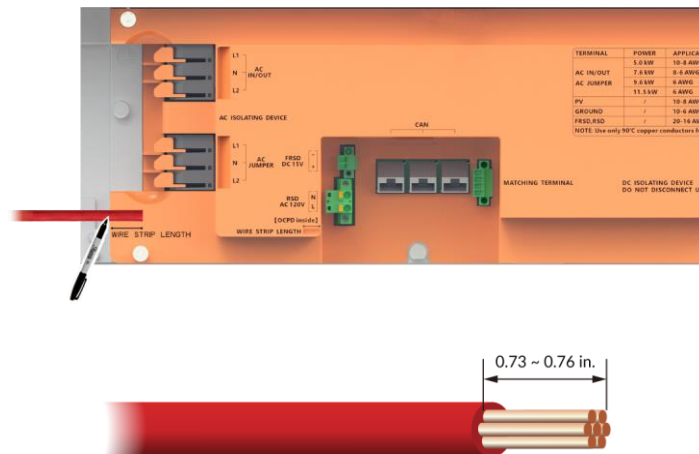

- **aGate terminals:** Varies by breaker configuration

Refer to [Wiring Requirements](#) for appropriate strip length.



WARNING: Ensure proper cabling, stripping, and secure connections to prevent equipment damage or fire hazards.

Fully insert the striped wire until it reaches the bottom of the terminal, then press down the terminal lever to secure the connection.

The **AC IN/OUT** and **AC JUMPER** terminals are functionally interchangeable. In case of a terminal failure, the alternate terminal may be used as a backup.

aGate Terminal Selection

When connecting aPower(s) to the aGate, it is necessary to select the appropriate terminals based on the number of installed aPower units: aPower terminals or backup loads terminals. Select appropriate circuit breakers or combiner box to ensure safe and compliant installation.

When using aGate backup load terminals for wiring, install the Backup Expansion Lugs on the aGate backup loads terminals. There are two sets of lugs: one set is designated for aPower input, and another set is intended for the backup main panel output.

Refer to [Table 5 aPower Breaker](#) for compatible breaker.

For configurations involving four or more aPowers units, consult FranklinWH for technical support.

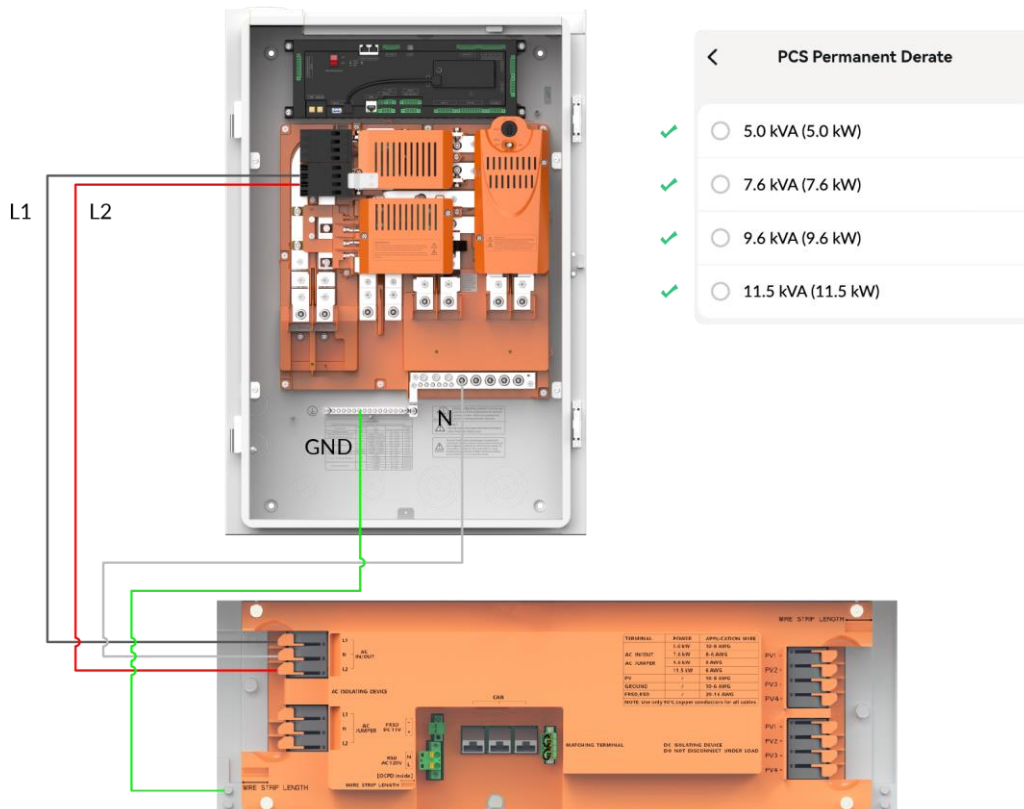

Wiring Torque to GND wire:
 6 AWG 45 lb·in (5.1 N·m)
 8 AWG 40 lb·in (4.5 N·m)
 10 AWG 35 lb·in (4.0 N·m)

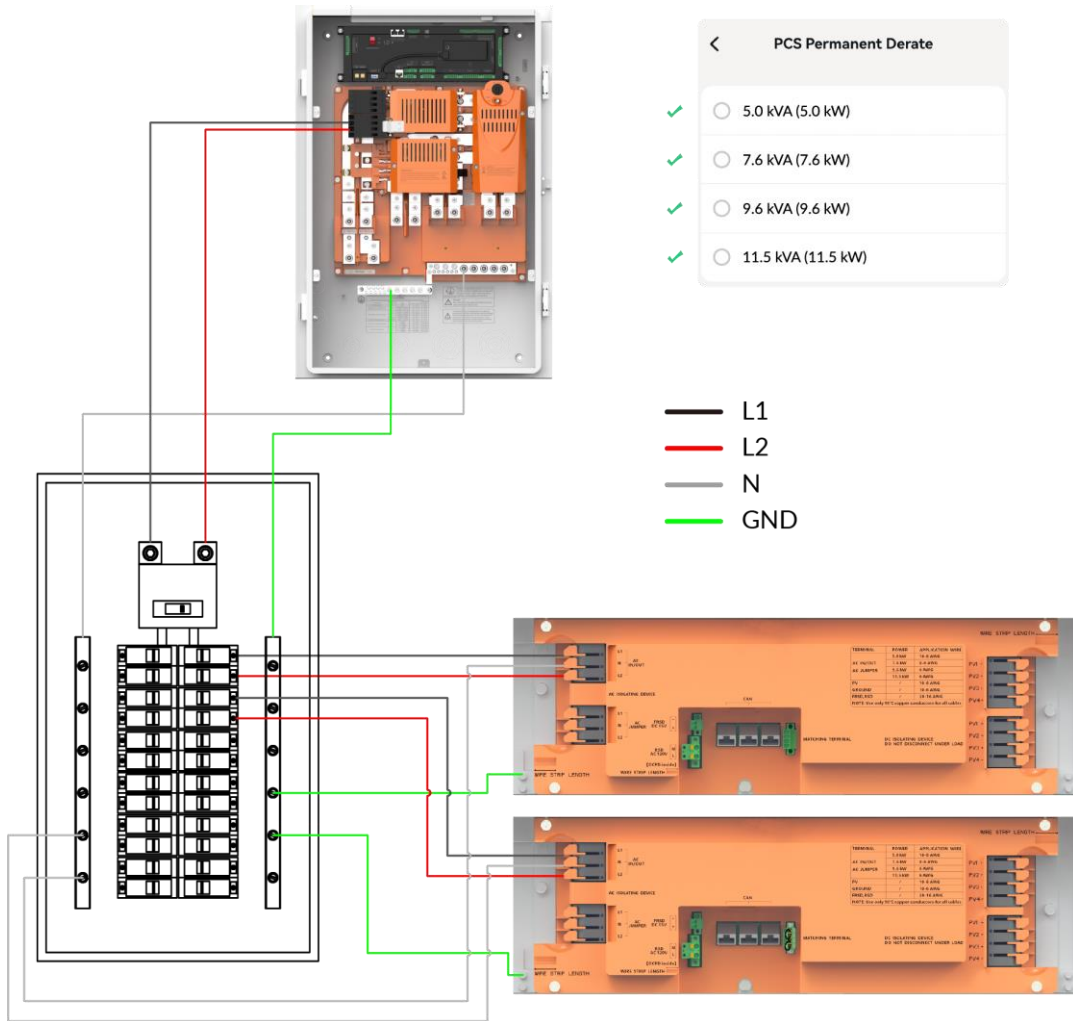

Wiring Torque to GND wire:
 6 AWG 45 lb-in (5.1 N·m)
 8 AWG 40 lb-in (4.5 N·m)
 10 AWG 35 lb-in (4.0 N·m)

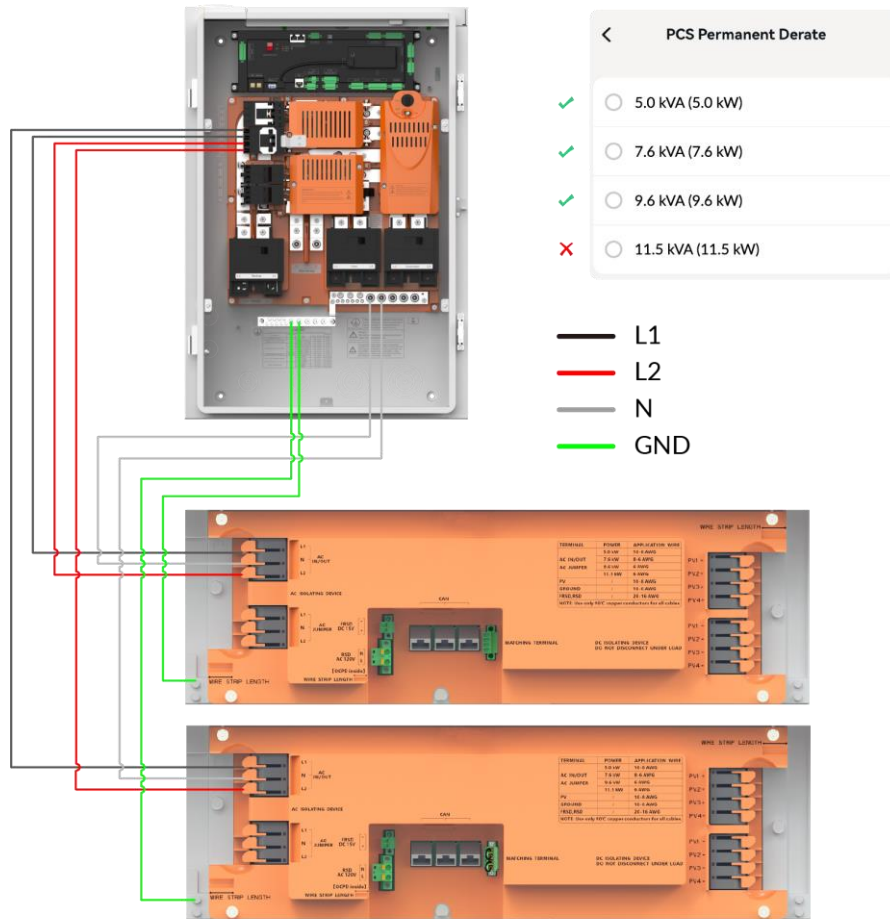

Wiring Torque to GND wire:
 6 AWG 45 lb-in (5.1 N·m)
 8 AWG 40 lb-in (4.5 N·m)
 10 AWG 35 lb-in (4.0 N·m)

NOTE



If a quad breaker is installed, limit the aPower output to ≤ 9.6 kW. The 11.5 kW setting requires a 60 A breaker.

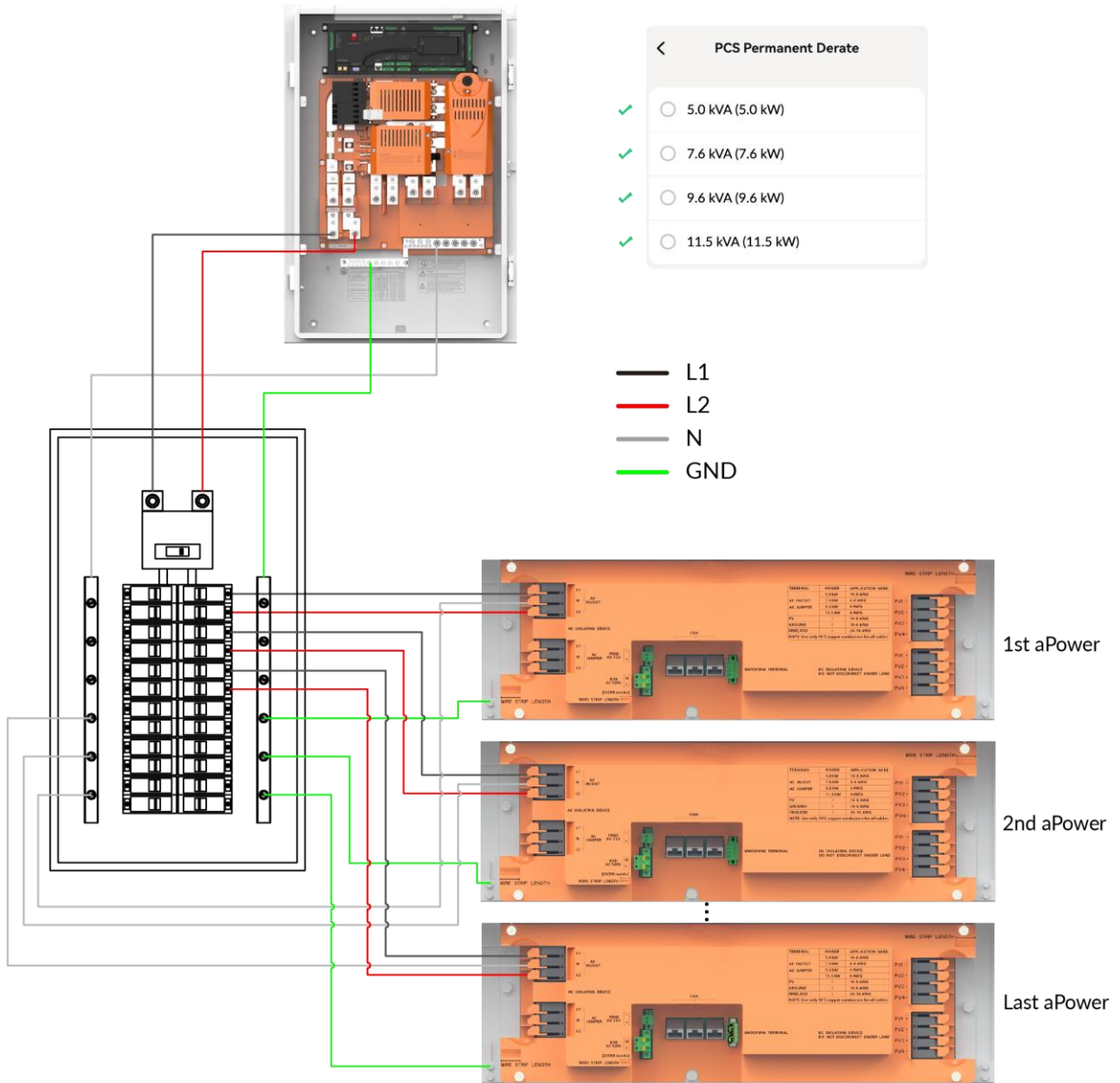

Wiring Torque to GND wire:

6 AWG	45 lb-in (5.1 N-m)
8 AWG	40 lb-in (4.5 N-m)
10 AWG	35 lb-in (4.0 N-m)

Mixed Configuration: aPower S, aPower 2, and aPower X 1.3 Wired in Parallel

The FranklinWH aPower S maintains backward compatibility with aPower 2 and aPower X 1.3, enabling seamless integration into existing installations to expand power and energy capacity.

The aPower S is compatible with aGate X 1.3 and above.

For mixed configurations involving four or more aPower S units, consult engineering@franklinwh.com for technical support.

Installation Requirements

- Calculate the cable gauge and circuit breaker ratings based on the total system capacity. All electrical installations must comply with applicable local codes and regulations.
- Use a combiner box or a compatible quadplex breaker to safely accommodate multiple hybrid unit connections.

WARNING



Before installation, ensure that all breakers are turned **OFF** and the system is fully de-energized.

Use a multimeter to verify 0 V at all terminals before proceeding.

Wear appropriate PPE for personal safety.

aGate Electrical Specifications (AGT-R1V2-US/AGT-R1V3-US)

- **aPower Terminals:** Maximum current 100 A, compatible with a 125 A circuit breaker.
- **Backup Loads Terminals:** Maximum current 160 A, compatible with a 200 A circuit breaker.

Determining Connection Terminal on the aGate for Hybrid Configuration

The four levels of aPower S output options are 10 kW/11.5 kW, 9.6 kW, 7.6 kW, and 5.0 kW. Configure the battery rated power according to the specific household load requirements. Then, calculate the total system output and select appropriate terminals on the aGate for hybrid system connection.

Total Battery Power Output	Connection Terminals
≤ 20 kW	aPower terminals
> 20 kW	Backup loads terminals

An additional combiner box or quadplex breaker may be required depending on site-specific conditions. Refer to [Table 5 aPower Breakers](#) for compatible circuit breakers.

All aPower S units must be installed and wired in accordance with the instructions outlined in previous chapters. The following diagram illustrates the parallel connection for hybrid units.

1*aPower 2 + 1*aPower S + Combiner box solution

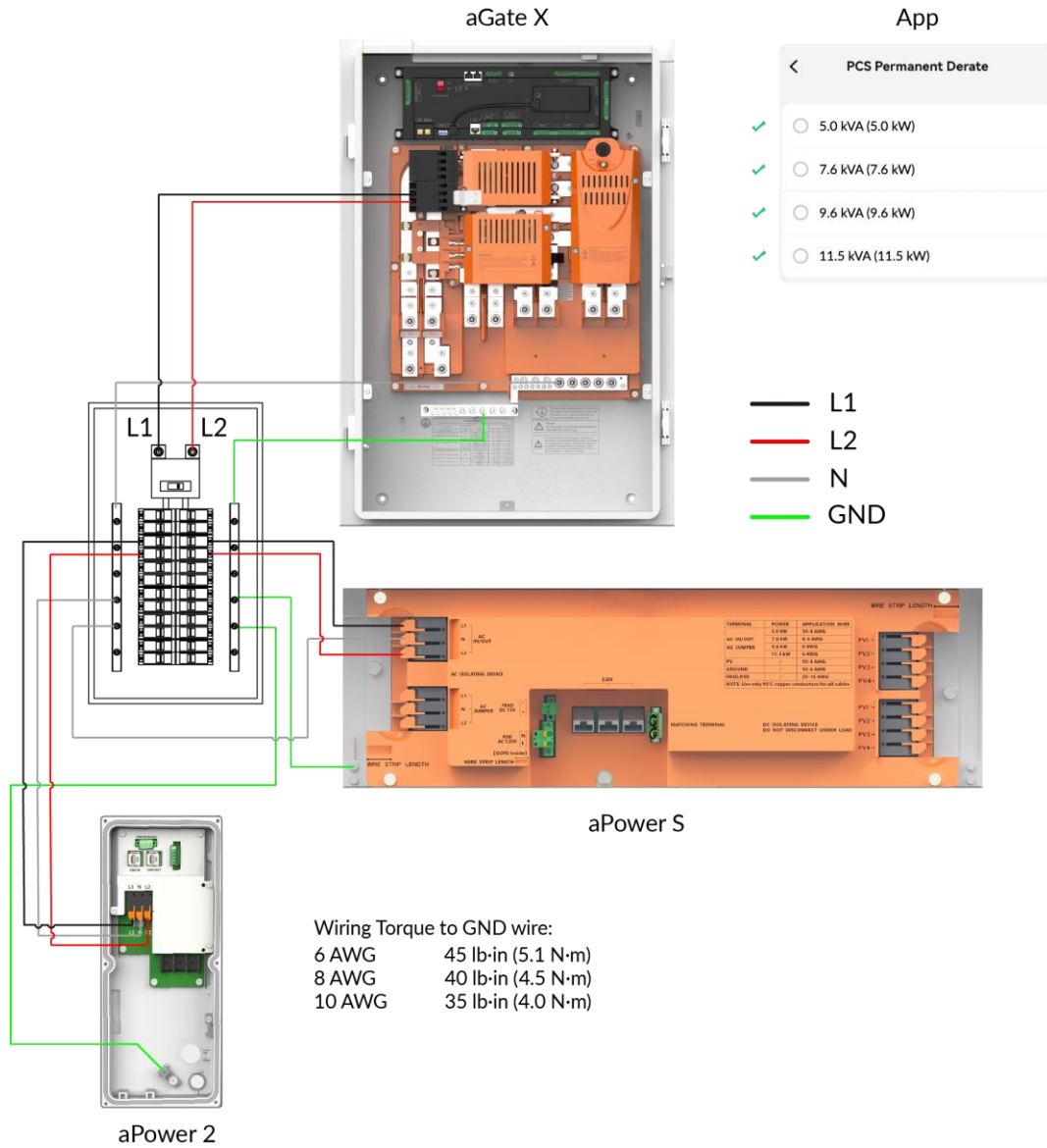

1*aPower 2 + 1*aPower S + Quad breaker solution

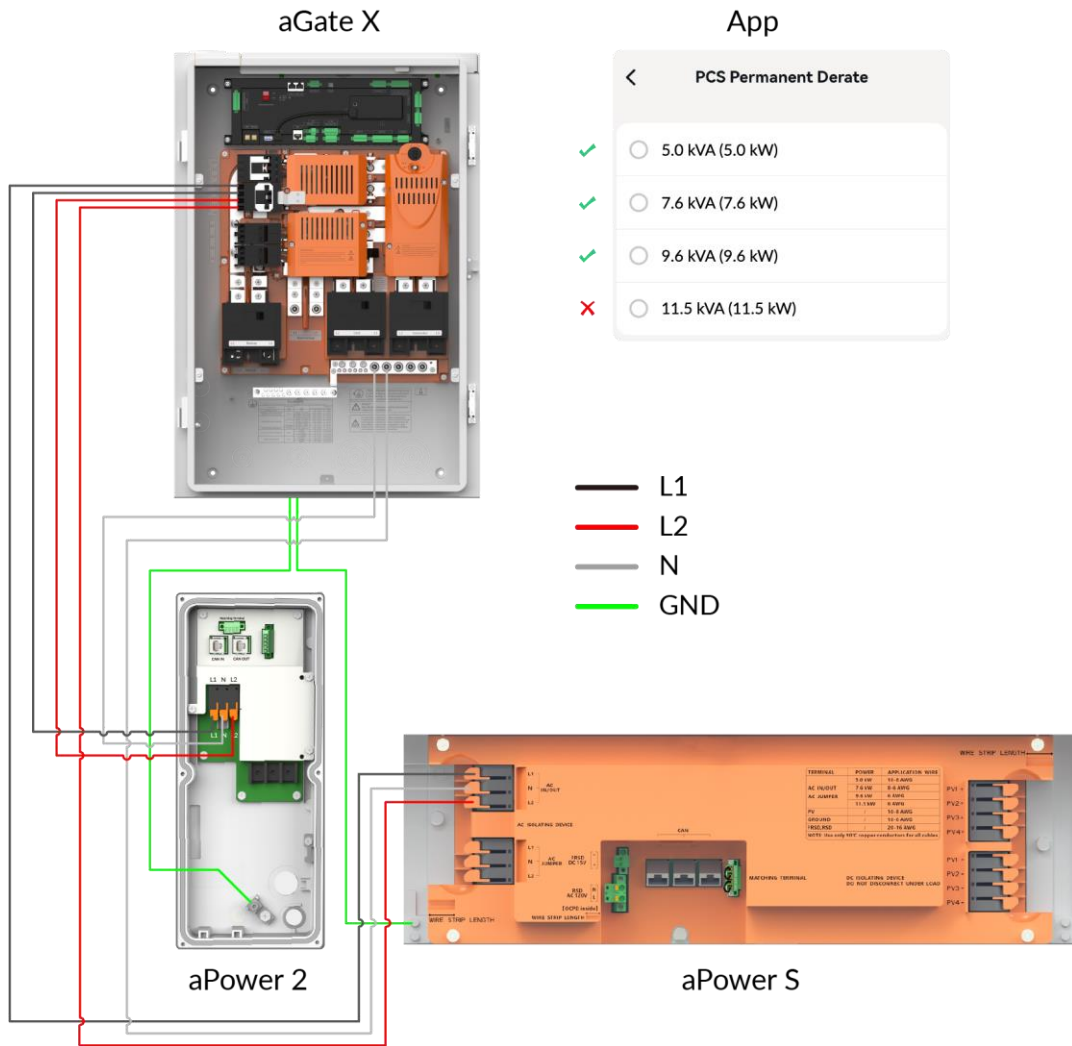

Wiring Torque to GND wire:
 6 AWG 45 lb-in (5.1 N·m)
 8 AWG 40 lb-in (4.5 N·m)
 10 AWG 35 lb-in (4.0 N·m)

NOTE



If a quad 50 A breaker is installed, limit the aPower output to 9.6 kW or less. The 11.5 kW setting requires a 60 A breaker.

More than 2 aPower units mixed

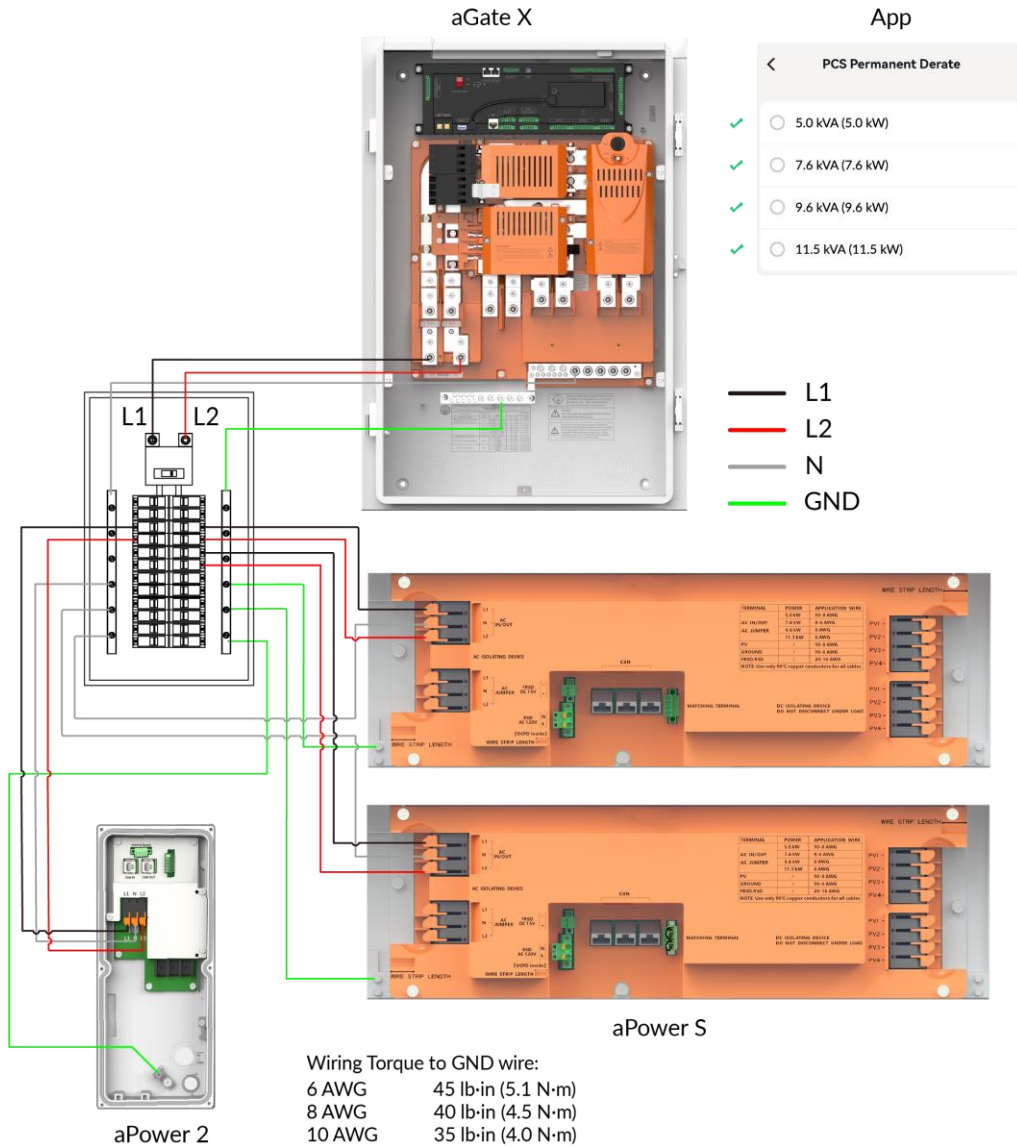

NOTE



Backup circuit breaker installation is not supported when the backup load terminals are in use for main power distribution wiring.

Wiring Requirements

aGate Terminal	Wire Gauge	Tool	Strip Length	Torque
Single-lug Terminal	4 AWG-250 MCM CU/AL	8 mm hex wrench 5/8-18 UNF Hex head screw	1 in	3/0 AWG-250 MCM, 275 LB-IN 4 AWG-2/0 AWG, 110 LB-IN
N bar	4 AWG-250 MCM CU/AL	8 mm hex wrench 5/8-18 UNF Hex head screw	1 in	3/0 AWG-250 MCM, 275 LB-IN 4 AWG-2/0 AWG, 110 LB-IN
	14 AWG-2/0 AWG CU/AL	5 mm hex wrench 7/16-20 UNF Hex head screw	1 in.	3 AWG-2/0 AWG, 110 LB-IN 14 AWG-4 AWG, 35 LB-IN
	14 AWG-4 AWG CU/AL	Straight screwdriver 1/4-28 UNF	0.6 in.	14 AWG-4 AWG, 26 LB-IN
G bar	14 AWG-2/0 AWG CU/AL	5 mm hex wrench Hex head screw: 7/16-20 UNF	0.8 in.	3 AWG-2/0 AWG, 110 LB-IN 14 AWG-4 AWG 35 LB-IN
	14 AWG-4 AWG CU/AL	Straight screwdriver 1/4-28 UNF	0.4 in./0.8 in.	14 AWG-4 AWG, 26 LB-IN

aPower Terminal	Rated Power	Wire Gauge	Strip Length
AC Terminal	5 kW	10 - 8 AWG	0.73 - 0.76 in. (18.5 to 19.3 mm)
	7.6 kW	8 - 6 AWG	
	> 9.6 kW	6 AWG	
PV Terminal	/	10 - 8 AWG	0.73 - 0.76 in. (18.5 to 19.3 mm)
GND	/	10 - 6 AWG	0.73 - 0.76 in. (18.5-19.3 mm)
RSD PWR	/	20 - 16 AWG	0.39 - 0.43 in. (10 to 11 mm)

NOTE



For aPower connection, use ONLY copper conductors, rated to a minimum of 194° F (90° C).

For aGate connection, use copper or aluminum wire, rated to a minimum of 167° F (75° C)

Install a Rapid Shutdown Switch

A Rapid Shutdown Device (RSD) switch may be installed on the aGate to protect against electrical hazards. Activating the RSD switch during installation or maintenance immediately shuts down the DC power from the solar panels to the aPower S. Initiating Rapid Shutdown powers down the storage batteries and triggers rooftop RSD devices.



The Power switch on the aPower S may be used as an RSD initiation switch. If the location of the aPower S complies with the requirements of the local AHJ, it is not necessary to install a separate switch.



Single aPower S unit within line of sight of the home's service entrance

- Ensure the RSD jumper in the aGate is in the factory-default position.
- The unit's ON/OFF switch can be used as the rapid shutdown initiator.

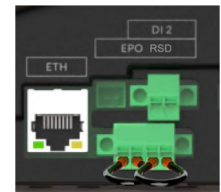

Multiple aPower S units or unit not within line of sight of the home's service entrance

- An External Switch is required.

Installers must procure and install RSD switch according to the local codes and regulations.



WARNING: The use of the RSD switch is strictly limited to installation and maintenance activities only.

Guidelines for RSD Switch Installation:

- RSD devices must be labeled properly according to NEC code.
- Must have an ON/OFF switch that maintains its position after being manually set to either status.
- Must have a clear indication of the ON/OFF positions.
- Must be outdoor rated (NEMA 3R or higher).
- The maximum length of the voltage wire between the RSD switch and the aGate should not exceed 150 feet (45.3 m).
- RSD switch type: Normally Closed (NC)
- The RSD shall have a rated voltage of 5 V or higher.

Installation Procedures

- 1) Make sure all breakers in the aGate and all switches connected to the aGate are disconnected. Wait at least five (5) minutes. Use a multimeter to check that the AC voltages at both input and output terminals of the aGate are zero (0), to ensure that all electrical equipment has been disconnected from the aGate.



WARNING: When the RSD switch is released, the RSD enters the OFF state, indicating that the RSD function has been activated. This ensures safe installation and maintenance work on the PV device.

- Remove the factory-installed jumper from the RSD terminal block connector on the EMS module.

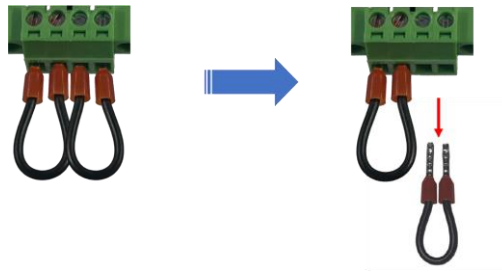

- Using wire rated at 24-16 AWG, connect an external RSD switch to the RSD terminal block (aGate X 1.3.1: AGT-R1V3-US) or DI1 terminal block (aGate X 1.3: AGT-R1V2-US).

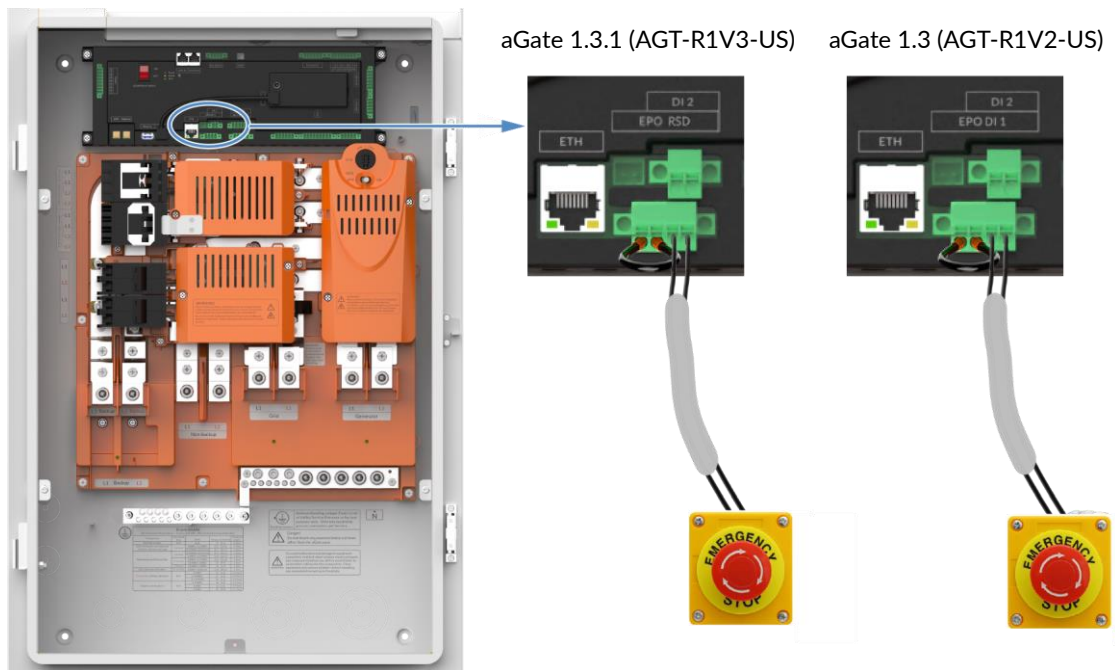

NOTE



For installations of aGate X 1.3 connected with aPower S, please use the DI1 terminal block to connect and engage the external RSD switch, which will activate the RSD.

- Make sure the RSD switch is OFF before operating the aPower.

Install an optional Emergency Power-Off Switch

When a system fault or abnormal condition occurs, such as thermal runaway, battery venting, or component failure, the user may manually press the emergency power off (EPO) switch button to power off the entire system, if it is safe to do so.



The external EPO switch is optional. Comply with all applicable codes and consult your local AHJ or utility before installation.

NOTE



If the external EPO switch is not connected to the FranklinWH System, keep the factory default configuration i.e., the factory-installed EPO terminal block connector on the EMS is short connected as shown in the right figure.

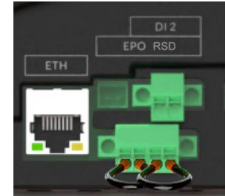

Guidelines for EPO Switch Selection and Installation:

- The notification and marking must be labeled as required by NEC section 706.15(C).
- Must have an ON/OFF switch that maintains its position after being manually set to either status.
- Must have a clear indication of the ON/OFF positions.
- Must be outdoor rated (NEMA 3R or higher).
- The maximum length of the voltage wire between the EPO switch and the aGate should not exceed 150 feet (45.3 m).
- EPO switch type: Normally Closed (NC)
- The EPO shall have a rated voltage of 5 V or higher.

Installation Procedures

- 1) Make sure all breakers in the aGate and all switches connected to the aGate are disconnected. Wait at least five (5) minutes. Use a multimeter to check that the AC voltages at both input and output terminals of the aGate are zero (0), to ensure that all electrical equipment has been disconnected from the aGate.

WARNING



When the EPO button is pressed, the EPO is in the OFF state. That means the EPO function has been activated to protect the system. At this time, the aPower(s) will be shut off and relays inside aGate (including the supply relay, the generator relay, the Smart Circuits relay, and the PV relay) will be disconnected. It also disconnects the utility grid and the backup port on aGate. Auxiliary power remains ON.

- 2) Remove the factory-installed jumper from the EPO terminal block connector on the EMS module.

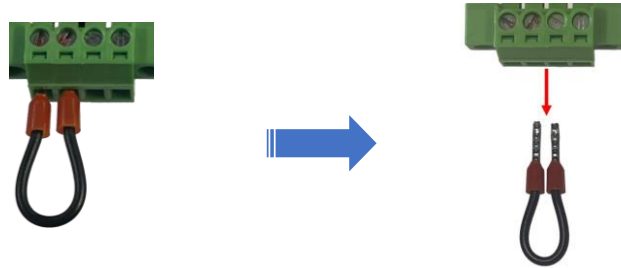

- 3) Using wire rated at 24-16 AWG, connect pins 3 and 4 (labeled EPO) to the C (common) and NC (normal close) of an external EPO switch.

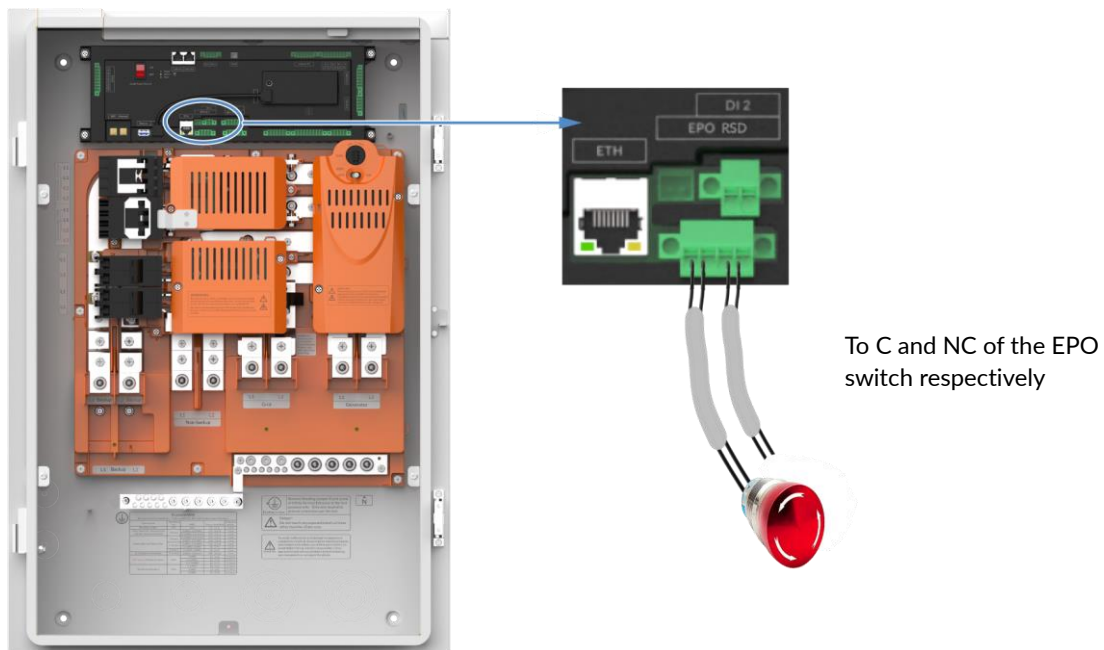

- 4) Paste the EPO Notice label to the aGate inner panel.

EPO Switch vs. RSD Switch Comparison

	EPO	RSD
Primary function	Emergency shutdown of all power sources and loads. Includes disconnection of utility grid.	Safety shutdown of PV, aPower, and generator/V2L sources while maintaining utility grid and load operation
De-energized	All power sources, plus backup and non-backup loads	PV AC, PV DC, generator/V2L, aPower
Remaining energized	None (full site shutdown)	Utility grid, line-side PV, all loads
Command type	Parent command	Child command
Relationship	Triggering EPO also triggers RSD functionality	Operates independently and does not interrupt the main grid circuit
Typical use case	Emergency full-site shutdown	PV installation, maintenance, or fault response while keeping the utility grid and loads energized

Usage Guidelines:

- Use **EPO** when you need a full site power shutdown (all sources and loads).
- Use **RSD** for PV-related installation or maintenance when grid/generator power should be preserved.

Complete Installation

Install the aPower Exterior Cover

1. After connecting the AC-side communications cable, power cable, and grounding wire, perform a pull test to verify secure connections. Then, bundle and secure all cables using the provided cable ties.

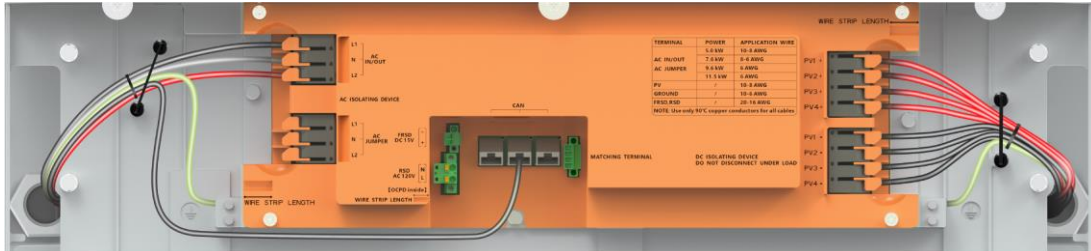

WARNING

To prevent damage, ensure all cables are properly bundled and secured.

2. Install the six front panel screws first, followed by the four screws on both sides of the aPower, tightening all the screws to a torque of 2.21 lb·ft (3 N·m).

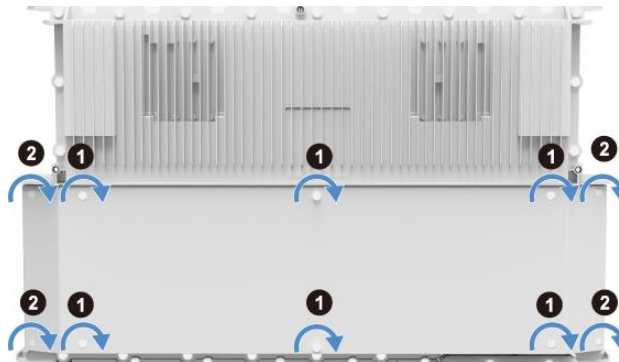

WARNING

Ensure all the ten screws are fully secured. Loose fasteners may lead to water intrusion and device failure.

3. Use diagonal pliers to remove the top or side knockout holes in accordance with the pull box position, wiring, and conduit layout.



4. Place the exterior cover close to the chassis for LED light strip's power cable connection.
 - a) Cut the cable tie that secures the LED light strip's power cable.



- b) Align the arrows on the male and female waterproof connectors, then insert the male head into the female one until a click sound.

NOTE

Two installers will be needed to complete the LED light strip power cables connection.

Make sure this connection achieves a NEMA 6P protection rating.

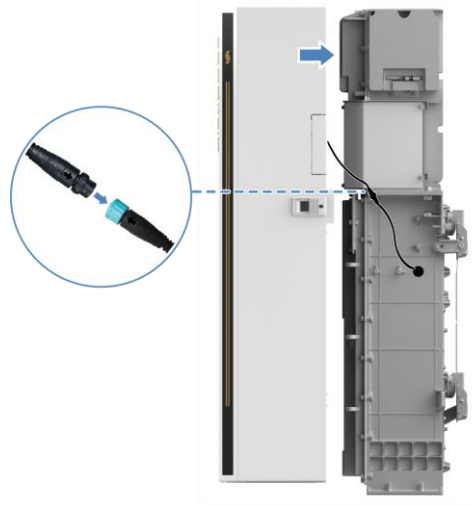

5. Insert eight locating pins on the exterior cover into the corresponding holes on the rear left and right side of the chassis. Securely fasten the four captive screws.

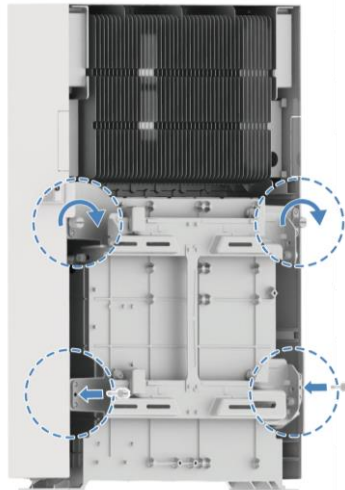

WARNING

To prevent potential safety hazards, do not place any item on top of the aPower S. Otherwise, item may fall through the heat dissipation holes onto the heating sink inside, possibly causing damage or creating safety risks.

- The installer shall provide a padlock to secure the aPower's On/Off switch after commissioning.

**WARNING**

Remove the cover film after the installation.

Re-Install the aGate Door and Inner Panel

- 1) Install the inner panel and fasten it by tightening the four original M5 x 12 combination bolts to 2.21 lb·ft (3.0 N·m).
- 2) Remove the knockouts on the inner panel for the installed breakers.

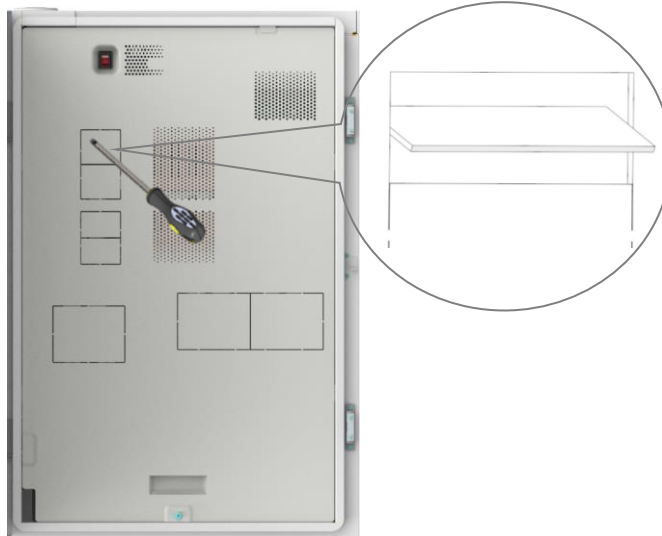

- 3) Attach the labels from the literature kit (bag with labels and accessories) onto the aGate inner panel to indicate circuit locations.
- 4) Re-install the aGate door.
- 5) Close the aGate door. Press the upper and lower latches to ensure that the door is tightly closed without any gaps.



WARNING

Gaps between the door and enclosure may cause water to leak into the aGate.

- 6) The installer shall provide a padlock to secure the aGate after commissioning.



Commissioning and Acceptance

The FranklinWH System installation is complete. For the commissioning and acceptance process, please refer to the *FranklinWH Commissioning Guide*.

Appendix 1: Allowed Breakers

Table 1 Grid Breakers

Grid Breaker			
S/N	Model	Current	Description
1	CSR2100	100 A	Eaton Circuit Breaker; 2-Pole, 25 kAIC, 100 A/240 V
2	CSR2125N	125 A	Eaton Circuit Breaker; 2-Pole, 25 kAIC, 125 A/240 V
3	CSR2150N	150 A	Eaton Circuit Breaker; 2-Pole, 25 kAIC, 150 A/240 V
4	CSR2175N	175 A	Eaton Circuit Breaker; 2-Pole, 25 kAIC, 175 A/240 V
5	CSR2200N	200 A	Eaton Circuit Breaker; 2-Pole, 25 kAIC, 200 A/240 V
6	BW2100	100 A	Eaton Circuit Breaker; 2-Pole, 10 kAIC, 100 A/240 V
7	BW2125	125 A	Eaton Circuit Breaker; 2-Pole, 10 kAIC, 125 A/240 V
8	BW2150	150 A	Eaton Circuit Breaker; 2-Pole, 10 kAIC, 150 A/240 V
9	BW2175	175 A	Eaton Circuit Breaker; 2-Pole, 10 kAIC, 175 A/240 V
10	BW2200	200 A	Eaton Circuit Breaker; 2-Pole, 10 kAIC, 200 A/240 V
11	BWH2100N	100 A	Eaton Circuit Breaker; 2-Pole, 25 kAIC, 100 A/240 V
12	BWH2125N	125 A	Eaton Circuit Breaker; 2-Pole, 25 kAIC, 125 A/240 V
13	BWH2150N	150 A	Eaton Circuit Breaker; 2-Pole, 25 kAIC, 150 A/240 V
14	BWH2175N	175 A	Eaton Circuit Breaker; 2-Pole, 25 kAIC, 175 A/240 V
15	BWH2200N	200 A	Eaton Circuit Breaker; 2-Pole, 25 kAIC, 200 A/240 V

***NOTE:** When opting for a 25 kAIC grid breaker, it is necessary to select a backup power circuit breaker with a matching 25 kAIC rating as well.

Table 2 Backup Port Breakers

Backup Port Breaker			
S/N	Model	Current	Description
1	CSR2100	100 A	Eaton Circuit Breaker; 2-Pole, 25 kAIC, 100 A/240 V
2	CSR2125N	125 A	Eaton Circuit Breaker; 2-Pole, 25 kAIC, 125 A/240 V
3	CSR2150N	150 A	Eaton Circuit Breaker; 2-Pole, 25 kAIC, 150 A/240 V
4	CSR2175N	175 A	Eaton Circuit Breaker; 2-Pole, 25 kAIC, 175 A/240 V
5	CSR2200N	200 A	Eaton Circuit Breaker; 2-Pole, 25 kAIC, 200 A/240 V
6	BW2100	100 A	Eaton Circuit Breaker; 2-Pole, 10 kAIC, 100 A/240 V
7	BW2125	125 A	Eaton Circuit Breaker; 2-Pole, 10 kAIC, 125 A/240 V
8	BW2150	150 A	Eaton Circuit Breaker; 2-Pole, 10 kAIC, 150 A/240 V
9	BW2175	175 A	Eaton Circuit Breaker; 2-Pole, 10 kAIC, 175 A/240 V
10	BW2200	200 A	Eaton Circuit Breaker; 2-Pole, 10 kAIC, 200 A/240 V
11	BWH2100N	100 A	Eaton Circuit Breaker; 2-Pole, 25 kAIC, 100 A/240 V
12	BWH2125N	125 A	Eaton Circuit Breaker; 2-Pole, 25 kAIC, 125 A/240 V
13	BWH2150N	150 A	Eaton Circuit Breaker; 2-Pole, 25 kAIC, 150 A/240 V
14	BWH2175N	175 A	Eaton Circuit Breaker; 2-Pole, 25 kAIC, 175 A/240 V
15	BWH2200N	200 A	Eaton Circuit Breaker; 2-Pole, 25 kAIC, 200 A/240 V

NOTE: When opting for a 25 kAIC Backup circuit breaker, it is necessary to select a grid circuit breaker with a matching 25 kAIC rating. If choose 10 kAIC Grid breaker, for 22KA short-circuit rating, the marked current rating shall be followed with the words "Max - see main circuit breaker rating."

Table 3 Generator Breakers

Generator Breaker			
S/N	Model	Current	Description
1	CSR2100	100 A	Eaton Circuit Breaker; 2-Pole, 25 kAIC, 100 A/240 V
2	CSR2125N	125 A	Eaton Circuit Breaker; 2-Pole, 25 kAIC, 125 A/240 V
3	CSR2150N	150 A	Eaton Circuit Breaker; 2-Pole, 25 kAIC, 150 A/240 V
4	CSR2175N	175 A	Eaton Circuit Breaker; 2-Pole, 25 kAIC, 175 A/240 V
5	CSR2200N	200 A	Eaton Circuit Breaker; 2-Pole, 25 kAIC, 200 A/240 V
6	BW2100	100 A	Eaton Circuit Breaker; 2-Pole, 10 kAIC, 100 A/240 V
7	BW2125	125 A	Eaton Circuit Breaker; 2-Pole, 10 kAIC, 125 A/240 V
8	BW2150	150 A	Eaton Circuit Breaker; 2-Pole, 10 kAIC, 150 A/240 V
9	BW2175	175 A	Eaton Circuit Breaker; 2-Pole, 10 kAIC, 175 A/240 V
10	BW2200	200 A	Eaton Circuit Breaker; 2-Pole, 10 kAIC, 200 A/240 V
11	BWH2100N	100 A	Eaton Circuit Breaker; 2-Pole, 25 kAIC, 100 A/240 V
12	BWH2125N	125 A	Eaton Circuit Breaker; 2-Pole, 25 kAIC, 125 A/240 V
13	BWH2150N	150 A	Eaton Circuit Breaker; 2-Pole, 25 kAIC, 150 A/240 V
14	BWH2175N	175 A	Eaton Circuit Breaker; 2-Pole, 25 kAIC, 175 A/240 V
15	BWH2200N	200 A	Eaton Circuit Breaker; 2-Pole, 25 kAIC, 200 A/240 V

*NOTE: The generator breaker may be installed outside the aGate depending on the site condition.

Table 4 PV Breakers

PV Breaker				
S/N	Description	Manufacturer Model 1	Manufacturer Model 2	Manufacturer Model 3
1	2-Pole, 10 kAIC, 30 A/240 V	Eaton #BR230	Siemens #Q230	Schneider #HOM230
2	2-Pole, 10 kAIC, 40 A/240 V	Eaton #BR240	Siemens #Q240	Schneider #HOM240
3	2-Pole, 10 kAIC, 50 A/240 V	Eaton #BR250	Siemens #Q250	Schneider #HOM250
4	2-Pole, 10 kAIC, 60 A/240 V	Eaton #BR260	Siemens #Q260	Schneider #HOM260
5	2-Pole, 10 kAIC, 70 A/240 V	Eaton #BR270	Siemens #Q270	Schneider #HOM270
6	2-Pole, 10 kAIC, 80 A/240 V	Eaton #BR280	Siemens #Q280	Schneider #HOM280
7	2-Pole, 22 kAIC, 30 A/240 V	Eaton #BRH230	Siemens #Q230H	N/A
8	2-Pole, 22 kAIC, 40 A/240 V	Eaton #BRH240	Siemens #Q240H	N/A
9	2-Pole, 22 kAIC, 50 A/240 V	Eaton #BRH250	Siemens #Q250H	N/A
10	2-Pole, 22 kAIC, 60 A/240 V	Eaton #BRH260	Siemens #Q260H	N/A
11	2-Pole, 22 kAIC, 70 A/240 V	Eaton #BRH270	Siemens #Q270H	N/A
12	2-Pole, 22 kAIC, 80 A/240 V	Eaton #BRH280	Siemens #Q280H	N/A
13	2-Pole, 10 kAIC, 2X15A/240 V	Eaton #BQC215215	Siemens #Q21515CT2	Schneider #HOMT215215
14	2-Pole, 10 kAIC, 2X20A/240 V	Eaton #BQC220220	Siemens #Q22020CT2	Schneider #HOMT220220
15	2-Pole, 10 kAIC, 2X30A/240 V	Eaton #BQC230230	Siemens #Q23030CT2	Schneider #HOMT230230
16	2-Pole, 10 kAIC, 2X40A/240 V	Eaton #BQC240240	Siemens #Q24040CT2	N/A
17	2-Pole, 10 kAIC, 2X15A/240 V	Eaton #BQ215215	N/A	N/A
18	2-Pole, 10 kAIC, 2X20A/240 V	Eaton #BQ220220	N/A	N/A
19	2-Pole, 10 kAIC, 2X30A/240 V	Eaton #BQ230230	N/A	N/A
20	2-Pole, 10 kAIC, 2X40A/240 V	Eaton #BQ240240	N/A	N/A

Table 5 aPower Breakers

aPower Breaker				
S/N	Description	Manufacturer Model 1	Manufacturer Model 2	Manufacturer Model 3
1	2-Pole, 10 kAIC, 30 A/240 V	Eaton #BR230	Siemens #Q230	Schneider #HOM230
2	2-Pole, 10 kAIC, 40 A/240 V	Eaton #BR240	Siemens #Q240	Schneider #HOM240
3	2-Pole, 10 kAIC, 50 A/240 V	Eaton #BR250	Siemens #Q250	Schneider #HOM250
4	2-Pole, 10 kAIC, 60 A/240 V	Eaton #BR260	Siemens #Q260	Schneider #HOM260
5	2-Pole, 10 kAIC, 70 A/240 V	Eaton #BR270	Siemens #Q270	Schneider #HOM270
6	2-Pole, 10 kAIC, 80 A/240 V	Eaton #BR280	Siemens #Q280	Schneider #HOM280
7	2-Pole, 10 kAIC, 90 A/240 V	Eaton #BR290	Siemens #Q290	Schneider #HOM290
8	2-Pole, 10 kAIC, 100 A/240 V	Eaton #BR2100	Siemens #Q2100	Schneider #HOM2100
9	2-Pole, 10 kAIC, 125 A/240 V	Eaton# BR2125	Siemen# Q2125	Schneider# HOM2125
10	2-Pole, 22 kAIC, 30 A/240 V	Eaton #BRH230	Siemens #Q230H	N/A
11	2-Pole, 22 kAIC, 40 A/240 V	Eaton #BRH240	Siemens #Q240H	N/A
12	2-Pole, 22 kAIC, 50 A/240 V	Eaton #BRH250	Siemens #Q250H	N/A
13	2-Pole, 22 kAIC, 60 A/240 V	Eaton #BRH260	Siemens #Q260H	N/A
14	2-Pole, 22 kAIC, 70 A/240 V	Eaton #BRH270	Siemens #Q270H	N/A
15	2-Pole, 22 kAIC, 80 A/240 V	Eaton #BRH280	Siemens #Q280H	N/A
16	2-Pole, 22 kAIC, 90 A/240 V	Eaton #BRH290	Siemens #Q290H	N/A
17	2-Pole, 22 kAIC, 100 A/240 V	Eaton #BRH2100	Siemens #Q2100H	N/A
18	2-Pole, 22 kAIC, 125 A/240 V	Eaton# BRH2125	Siemen# Q2125H	N/A
19	2-Pole, 10 kAIC, 2X30A/240 V	Eaton #BQC230230	Siemens #Q23030CT2	Schneider #HOMT230230
20	2-Pole, 10 kAIC, 2X40A/240 V	Eaton #BQC240240	Siemens #Q24040CT2	N/A
21	2-Pole, 10 kAIC, 2X50A/240 V	Eaton #BQC250250	N/A	N/A
22	2-Pole, 10 kAIC, 2X30A/240 V	Eaton #BQ230230	N/A	N/A
23	2-Pole, 10 kAIC, 2X40A/240 V	Eaton #BQ240240	N/A	N/A
24	2-Pole, 10 kAIC, 2X50A/240 V	Eaton #BQ250250	N/A	N/A

Table 6 Smart Circuit Breakers

Breaker for Smart Circuit 1 and 2 (1-Pole)			
S/N	Model	Current	Description
1	CH120	20 A	Eaton Circuit Breaker; 1-Pole, 10 kAIC, 20 A/240 V
2	CH130	30 A	Eaton Circuit Breaker; 1-Pole, 10 kAIC, 30 A/240 V
3	CH135	35 A	Eaton Circuit Breaker; 1-Pole, 10 kAIC, 35 A/240 V
4	CH140	40 A	Eaton Circuit Breaker; 1-Pole, 10 kAIC, 40 A/240 V
5	CH145	45 A	Eaton Circuit Breaker; 1-Pole, 10 kAIC, 45 A/240 V
6	CH150	50 A	Eaton Circuit Breaker; 1-Pole, 10 kAIC, 50 A/240 V
7	CHF130	30 A	Eaton Circuit Breaker; 1-Pole, 10 kAIC, 30 A/240 V
8	CHF135	35 A	Eaton Circuit Breaker; 1-Pole, 10 kAIC, 35 A/240 V
9	CHF140	40 A	Eaton Circuit Breaker; 1-Pole, 10 kAIC, 40 A/240 V
10	CHF145	45 A	Eaton Circuit Breaker; 1-Pole, 10 kAIC, 45 A/240 V
11	CHF150	50 A	Eaton Circuit Breaker; 1-Pole, 10 kAIC, 50 A/240 V
Breaker for Smart Circuit 1 + Circuit 2 (2-Pole)			
S/N	Model	Current	Description
1	CH230	30 A	Eaton Circuit Breaker; 2-Pole, 10 kAIC, 30 A/240 V
2	CH235	35 A	Eaton Circuit Breaker; 2-Pole, 10 kAIC, 35 A/240 V
3	CH240	40 A	Eaton Circuit Breaker; 2-Pole, 10 kAIC, 40 A/240 V
4	CH245	45 A	Eaton Circuit Breaker; 2-Pole, 10 kAIC, 45 A/240 V
5	CH250	50 A	Eaton Circuit Breaker; 2-Pole, 10 kAIC, 50 A/240 V
6	CHF230	30 A	Eaton Circuit Breaker; 2-Pole, 10 kAIC, 30 A/240 V
7	CHF235	35 A	Eaton Circuit Breaker; 2-Pole, 10 kAIC, 35 A/240 V
8	CHF240	40 A	Eaton Circuit Breaker; 2-Pole, 10 kAIC, 40 A/240 V
9	CHF245	45 A	Eaton Circuit Breaker; 2-Pole, 10 kAIC, 45 A/240 V
10	CHF250	50 A	Eaton Circuit Breaker; 2-Pole, 10 kAIC, 50 A/240 V

Breaker for Smart Circuit 3			
S/N	Model	Current	Description
1	CH230	30 A	Eaton Circuit Breaker; 2-Pole, 10 kAIC, 30 A/240 V
2	CH235	35 A	Eaton Circuit Breaker; 2-Pole, 10 kAIC, 35 A/240 V
3	CH240	40 A	Eaton Circuit Breaker; 2-Pole, 10 kAIC, 40 A/240 V
4	CH245	45 A	Eaton Circuit Breaker; 2-Pole, 10 kAIC, 45 A/240 V
5	CH250	50 A	Eaton Circuit Breaker; 2-Pole, 10 kAIC, 50 A/240 V
6	CH260	60 A	Eaton Circuit Breaker; 2-Pole, 10 kAIC, 60 A/240 V
7	CH270	70 A	Eaton Circuit Breaker; 2-Pole, 10 kAIC, 70 A/240 V
8	CH280	80 A	Eaton Circuit Breaker; 2-Pole, 10 kAIC, 80 A/240 V
9	CHF230	30 A	Eaton Circuit Breaker; 2-Pole, 10 kAIC, 30 A/240 V
10	CHF235	35 A	Eaton Circuit Breaker; 2-Pole, 10 kAIC, 35 A/240 V
11	CHF240	40 A	Eaton Circuit Breaker; 2-Pole, 10 kAIC, 40 A/240 V
12	CHF245	45 A	Eaton Circuit Breaker; 2-Pole, 10 kAIC, 45 A/240 V
13	CHF250	50 A	Eaton Circuit Breaker; 2-Pole, 10 kAIC, 50 A/240 V
GFCI breaker for Smart Circuit 1 + Circuit 2 (2 pole)			
S/N	Model	Current	Description
1	CHFN215EP	15 A	CH 2-Pole Equipment Protection Breaker, 15 A, Pigtail, 10 kAIC, 30 mA Equipment Protection, #14-3 AWG
2	CHFN220EP	20 A	CH 2-Pole Equipment Protection Breaker, 20 A, Pigtail, 10 kAIC, 30 mA Equipment Protection, #14-3 AWG
3	CHFN230EP	30 A	CH 2-Pole Equipment Protection Breaker, 30 A, Pigtail, 10 kAIC, 30 mA Equipment Protection, #14-3 AWG
4	CHFN240EP	40 A	CH 2-Pole Equipment Protection Breaker, 40 A, Pigtail, 10 kAIC, 30 mA Equipment Protection, #14-3 AWG
5	CHFN250EP	50 A	CH 2-Pole Equipment Protection Breaker, 50 A, Pigtail, 10 kAIC, 30 mA Equipment Protection, #14-3 AWG
GFCI breaker for Smart Circuit 3 (2 pole)			
S/N	Model	Current	Description
1	CHFN215EP	15 A	CH 2-Pole Equipment Protection Breaker, 15 A, Pigtail, 10 kAIC, 30 mA Equipment Protection, #14-3 AWG
2	CHFN220EP	20 A	CH 2-Pole Equipment Protection Breaker, 20 A, Pigtail, 10 kAIC, 30 mA Equipment Protection, #14-3 AWG
3	CHFN230EP	30 A	CH 2-Pole Equipment Protection Breaker, 30 A, Pigtail, 10 kAIC, 30 mA Equipment Protection, #14-3 AWG
4	CHFN240EP	40 A	CH 2-Pole Equipment Protection Breaker, 40 A, Pigtail, 10 kAIC, 30 mA Equipment Protection, #14-3 AWG
5	CHFN250EP	50 A	CH 2-Pole Equipment Protection Breaker, 50 A, Pigtail, 10 kAIC, 30 mA Equipment Protection, #14-3 AWG
6	CHFN260EP	60 A	CH 2-Pole Equipment Protection Breaker, 60 A, Pigtail, 10 kAIC, 30 mA Equipment Protection, #14-3 AWG

***NOTE:** NEC 2023 requires GFCI protection in kitchens, bathrooms, and outdoors. Must comply with all applicable codes and standards set by local AHJ.

Use GFCI breakers **only** for the aGate Smart Circuits Module. Do not connect them to an aPower, PV, or generator/V2L breaker position.

GFCI circuit breakers may not be suitable for the following home appliances: appliances using inverter technology, appliances with high inrush current, critical equipment with extremely high requirement for power continuity, and certain early-model or design-sensitive small appliances. Check the appliance manual for any specific instructions regarding GFCI compatibility.

Table 7 Breakers in a Combiner Box

S/N	aPower Rated Power	Recommended Breaker
1	5 kW	30 A
2	7.6 kW	40 A
3	9.6 kW	50 A
4	10 kW/11.5 kW	60 A

***NOTE:** If homeowners need capacity expansion, configure the circuit breaker and cables based on the maximum output of 11.5 kW.

Appendix 2: Datasheet

aPower S

BAT DC Terminal, Bi-Directional				
Nominal voltage (V)	51.2 V			
Max. charging current (A)	166 A			
Max. charging power (kW)	8 kW			
Max. discharging current (A)	201 A			
Max. discharging power (kW)	11.5 kW continuous			
- With PV Input	10 kW continuous			
- Battery Only				
AC Terminal, Bi-Directional (Grid-Tied)				
Nominal AC voltage	120/208 V, 120/240 V, 60 Hz			
Coupling	Hybrid-Coupled			
Phase	2 W+N+PE			
Nominal output power (AC)	5 kW	7.6 kW	9.6 kW	10 kW/11.5 kW
Maximum apparent power	5 kVA	7.6 kVA	9.6 kVA	11.5 kVA
Maximum continuous current	21 A	32 A	40 A	48 A
Overcurrent protection device	30 A	40 A	50 A	60 A
Maximum continuous input power	5 kW	7.6 kW	8 kW	8 kW
Power factor	±1	±1	±1	±0.87/±1
AC Terminal, Bi-Directional (Off-Grid)				
THDU	< 1%			
Voltage regulation accuracy	±1%			
Frequency accuracy	±0.1 Hz			
Maximum half-wave load capability	5 kW			
Maximum peak output power	15 kW @ 10 S			
Maximum transient load capacity	25 kW @ 1 S			
Load imbalance ratio	100%			
Load start capability	185 A LRA			
Solar Terminal				
PV DC input voltage range	60 - 600 Vdc			
Withstand voltage	600 Vdc			
PV DC MPPT voltage range	90 - 480 Vdc			
Maximum solar STC input	20 kW			
Maximum photovoltaic input power	15 kW			
Single photovoltaic input power	5 kW			
MPPTs	4			
Maximum current per MPPT (Imp)	15 A			
Maximum short circuit current per MPPT (Isc)	20 A			

Others	
Operation temperature range	-4° F to 122° F (-20° C to +50° C), derating above at +40° C
Storage temperature range	≤24 hours: -22° F to 140° F (-30° C to +60° C) ≤ 9 months: -4° F to 113° F (-20° C to +45° C) ≤ 12 months: -4° F to 95° F (-20° C to +35° C)
Ingress protection	IP67 (Battery Pack & Inverter) IP55 (Wiring)
Operating Humidity (RH)	Up to 100%, non-condensing
Storage Humidity (RH)	Up to 100%, non-condensing
Certificate	UL9540; UL9540A; UL1973; UL1741; UL1741 SB; UL1741 PCS; UL 1741 Multimode; UL 1741 CRD; UL 3141; UL1699B; UL1998; UN38.3; IEEE 1547; IEEE 1547.1; CSA 22.2 No.107.1;
Dimensions (H x W x D)	45.2 in. x 29.5 in. x 11.8 in. (1149 mm x 750 mm x 300 mm)
Weight	388 lbs. (176 kg)

aGate

(1) Grid Terminal, Bi-Directional	
Nominal AC Grid voltage (V)	120/208 V; 120/240 V, (L1, L2, N)
Nominal AC Grid frequency (Hz)	60 Hz
Nominal AC input current (A)	160 A
Nominal AC input power (kW)	38.4 kW
Max. Continuous AC input power (kVA)	38.4 kVA
Max. overcurrent protection (amps), circuit breaker ratings	200 A
(2) Generator Terminal	
Nominal AC input voltage (V)	120/240 V, (L1, L2, N)
Nominal AC input frequency (Hz)	60 Hz
Nominal AC input current (A)	160 A
Nominal AC input power (kW)	38.4 kW
Max. Continuous AC input current (A)	160 A
Max. Continuous AC input power (kVA)	38.4 kVA
Max. overcurrent protection (amps), circuit breaker ratings	200 A
(3) Non-Backup Output Terminal	
Nominal AC output voltage (V)	120/208 V; 120/240 V, (L1, L2, N)
Nominal AC output frequency (Hz)	60 Hz
Nominal AC output current (A)	160 A
Nominal AC output power (kW)	38.4 kW
Max. Continuous AC output current (A)	160 A
Max. Continuous AC output power (kVA)	38.4 kVA
(4) Backup Output Terminal	
Nominal AC output voltage (V)	120/208 V; 120/240 V, (L1, L2, N)
Nominal AC output frequency (Hz)	60 Hz
Nominal AC output current (A)	160 A
Nominal AC output power (kW)	38.4 kW
Max. Continuous AC output current (A)	160 A
Max. Continuous AC output power (kVA)	38.4 kVA
(5) PV inverter's Input Terminal	
Nominal AC input voltage (V)	120/208 V; 120/240 V, (L1, L2, N)
Nominal AC input frequency (Hz)	60 Hz
Nominal AC input current (A)	64 A
Nominal AC input power (kW)	15.36 kW
Max. overcurrent protection (amps), circuit breaker ratings	80 A
(6) aPower AC Terminal, Bi-Directional	
Nominal AC voltage (V)	120/208 V; 120/240 V, (L1, L2, N)
Nominal AC frequency (Hz)	60 Hz
Nominal AC current (A)	100 A
Max. overcurrent protection (amps), circuit breaker ratings	125 A

(7) AC Output Terminal, Smart Circuit 1, 2	
Nominal AC output voltage (V)	120/208 V; 120/240 V, (L1, L2, N)
Nominal AC output frequency (Hz)	60 Hz
Nominal AC output current (A)	40 A
Nominal AC output power (kW) (L-L)	9.6 kW
Max. Continuous AC output current (A) (L-L)	40 A
Max. Continuous AC output power (kW) (L-L)	9.6 kW
Nominal AC output power (kW) (L-N)	4.8 kW
Max. Continuous AC output current (A) (L-N)	40 A
Max. Continuous AC output power (kW) (L-N)	4.8 kW
Max. output overcurrent protection (amps), circuit breaker ratings	50 A
(8) AC Output Terminal, Smart Circuit 3	
Nominal AC output voltage (V)	120/208 V; 240 V, (L1, L2)
Nominal AC output frequency (Hz)	60 Hz
Nominal AC output current (A)	64 A
Nominal AC output power (kW) (L-L)	15.36 kW
Max. Continuous AC output current (A) (L-L)	64 A
Max. Continuous AC output power (kVA) (L-L)	15.36 kVA
Nominal AC output power (kW) (L-N)	7.68 kW
Max. Continuous AC output current (A) (L-N)	64 A
Max. Continuous AC output power (kVA) (L-N)	7.68 kVA
Max. output overcurrent protection (amps), circuit breaker ratings	80 A
(9) Busbar	
Max. AC current (A)	280 A
Others	
Operation temperature range	-4° F to 122° F (-20° C to +50° C)
Storage temperature range	-22° F to 140° F (-30° C to +60° C)
Enclosure Type	Type 3R
Operating Humidity (RH)	Up to 100%, non-condensing
Storage Humidity (RH)	Up to 100%, non-condensing
Weight	38.6 lbs. (17.5kg)
Dimensions (W*H*D, inch)	21.7 in. x 31.5 in. x 6.3 in. (550 mm x 800 mm x 160 mm)
Ingress protection	IP44
Certificate	UL1741, UL67, UL869A, UL916, FCC Part 15 Class B

Appendix 3: Revision History

REVISION	DATE	DESCRIPTION
V1.1.3	May 26, 2026	<ul style="list-style-type: none"> Added compatible dual-channel RSD receiver type Updated DI1 port for RSD switch connection Added “EPO Switch vs. RSD Switch Comparison” table Updated installation clearance between the aPower S and RSS transmitter outdoor kit Added compatible Eaton CH breakers on a Smart Circuits module
V1.1.2	April 29, 2026	<p>Deleted the following three warnings:</p> <ul style="list-style-type: none"> “The FranklinWH System is composed of one or more aGate controllers, one or more aPower battery units, and other electrical components which may be used separately.” “An aPower may only be connected to the aPower breaker on the aGate or to the backup load terminals on aGate.” “The inputs from grid and generators may only be connected to the respective reserved terminals on the aGate.”
V1.1.1	March 10, 2026	<ul style="list-style-type: none"> Updated the side wall clearance per revised spec in Certification of UL9540A. Updated an installation site warning for FranklinWH System. Added a warning to remove the cover film. Added mixed configuration for aPower S, aPower 2, and aPower X.
V1.1	February 13, 2026	<ul style="list-style-type: none"> Updated direct sunshine instructions Updated the mounting bracket anchor points requirement Updated clearance to 4 inches between adjacent aPowers
V1.0	January 23, 2026	Initial release