



FranklinWH aPbox

Remotely and automatically manage a solar system

With built-in meters and CTs, the aPbox measures PV production that is remote from the aGate and sheds off excess solar production when required by the FranklinWH System. Homeowners can include their remote solar panels into the system without major changes to their current PV system wiring. The aPbox also allows homeowners with fewer batteries to integrate otherwise oversized solar systems while optimizing their system performance.



aPbox

Features

Flexible Connection

Flexibly connect remote solar panels to the FranklinWH System with minimal wiring changes.

Simple Installation

Save project time and labor costs.

Easy control

Each aGate controls up to 2 aPbox units, with a maximum of 130 A controllable solar current.

Wide Compatibility

Sheds excess solar generation to secure smooth system operation, leaving more options for battery unit selection.

Specification

Electrical Specifications

Nominal Voltage	120/208 VAC; 120 / 240 VAC, split
Frequency	60 Hz
Nominal Rated Current, Output	1 circuit, max 80 A
Nominal Rated Current, Input	2 circuits, max 80 A total

Environmental Specifications

Operating Temperature Range	-4 °F to 122 °F (-20 °C to 50 °C)
Storage Temperature Range	-22 °F to 140 °F (-30 °C to 60 °C)
Operating Humidity (RH)	Up to 100%
Maximum Altitude	9843 feet (3000 meters)
Type of Enclosure	NEMA Type 3R

Mechanical Specifications

Dimensions (W x H x D)	11.8 in x 17.7 in x 5.9 in (300 mm x 450 mm x 150 mm)
Weight	21.2 lbs. (9.6 kg)
Mounting Options	Wall mount (Indoors / Outdoors)

Compliance Information

Compliance	UL 1741
Environment	California Proposition 65
Emissions	FCC Part 15 Class B, ICES 003

Enhancing PV Management (PV on the aGate Solar Meter Upstream)

When the PV system's total output power exceeds the aGate's internal PV interface rating, connecting PV directly to the aGate may exceed feeder limits in on-grid mode or cause photovoltaic over-generation in off-grid mode. Installing the aPbox in front of the aGate's PV interface splits the output line of the PV system into two, with one passing through the aPbox and then connecting to the aGate's PV interface. The aPbox can disconnect one PV input, reducing the power sent to the aGate. This prevents the need to shut down the entire PV system, ensuring continued operation.

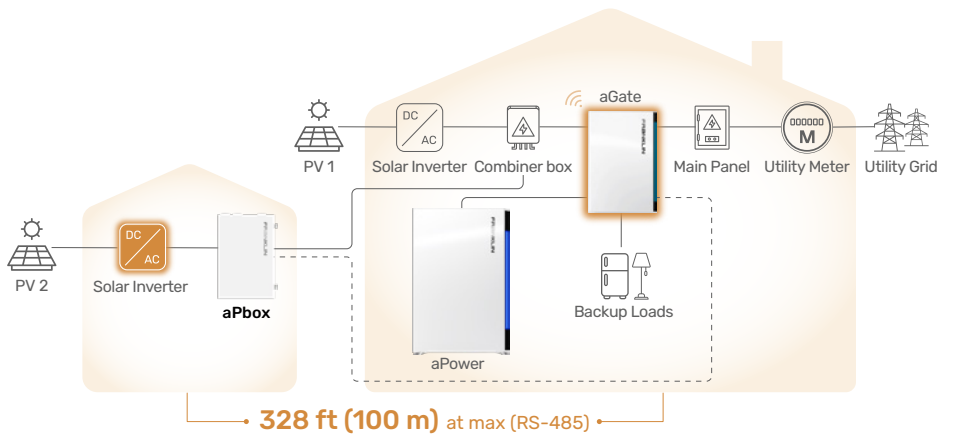

Enhancing PV Connectivity (PV on the line side)

Some solar AC connections are too distant for easy integration directly to the aGate. Adding an aPbox at the point of AC interconnection enables the aGate to include that PV system in its whole-home energy calculations.

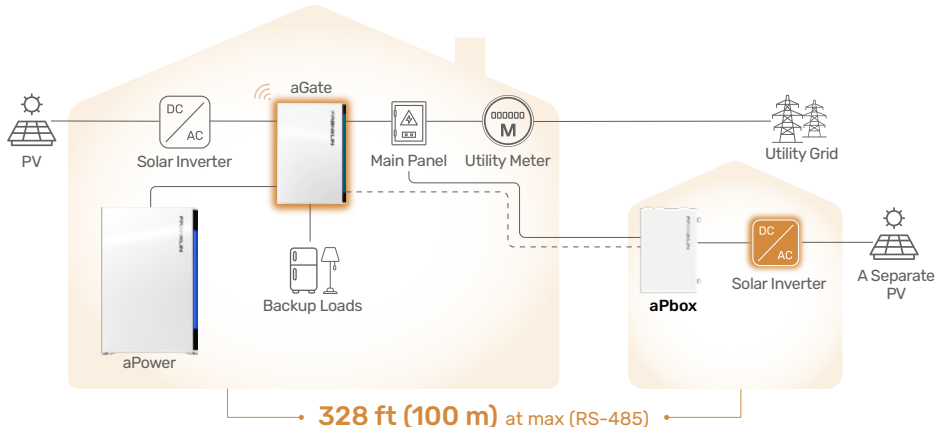

Oversized PV Retrofit (PV on the load side)

In some off-grid setups, a home's solar panels may output more energy during peak generating hours than the batteries are rated to offset with charging. Without an aPbox, this would require the users to add more battery storage to match the rate of solar production. The aPbox can selectively curtail excess solar generation so the customer can install fewer batteries and optimize the system performance.

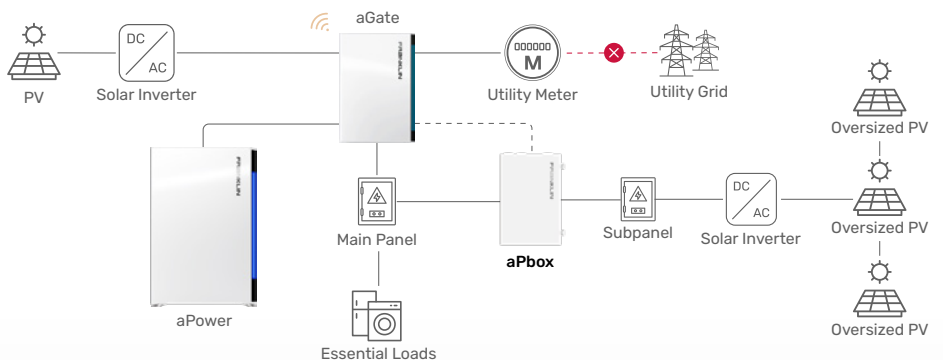

Address: 1731 Technology Dr., Suite 530 San Jose, CA 95110 Telephone: +1 888-837-2655 Email: info@franklinwh.com Website: www.franklinwh.com

Copyright 2025 FranklinWH Energy Storage Inc. All rights reserved. The Franklin logo, FranklinWH, and other trademarks or service names are the trademarks of FranklinWH Energy Storage Inc. The document is for informational purposes only, data subject to change. 2025-04-14

