



FranklinWH System User Manual

aPower 2, SKU: APR-10K15V2-US

aPower 1.3, SKU: APR-05K13V1-US

aGate X, SKU: AGT-R1V2-US; AGT-R1V3-US

©2026 FranklinWH Energy Storage Inc. All rights reserved.

All information in this Manual is subject to the copyright and other intellectual property rights of FranklinWH Energy Storage Inc. This manual may not be modified, copied or reproduced, in whole or in part, without the prior written permission of FranklinWH Energy Storage Inc.

Please visit [FranklinWH Support](#) for the latest FranklinWH documents.

All brands and trademarks mentioned in this document are the property of their respective owners, and their use in this document does not imply the sponsorship or recognition of their products or services.

Please read this document carefully to ensure the best reliability of the product and your warranty eligibility. For further information about the warranty, please refer to the **FranklinWH Limited Warranty**.

Information or recommendations in this document constitute any express or implied warranty.



Please read this document carefully before installing or using the FranklinWH equipment. Failure to follow any instructions or warnings in this document may result in damage to the equipment, personal electric shock, severe injury, or even death.

Product Information

FranklinWH system is composed of aPower, aGate and other electrical components, and this document applies only to the following products: aPower 1.3, aPower 2 and aGate X.

FranklinWH Energy Storage Inc. (FranklinWH) reserves the right to make any improvements to the product, and the contents in this document shall be subject to updates without further notification.

All images and pictures provided in this Manual are only for demonstration purposes and may differ in detail from the product, based on the product version.

Feedback

If you have any questions or comments, please send us an email at: service@franklinwh.com

Disposal of Scrapped Products

Scrapped products (including their internal chemicals and electrical materials) should not be disposed of with household waste. Please refer to your local laws and regulations regarding disposal.

FCC Compliance

This equipment has been tested and found to comply with the limits for a Class B digital device, pursuant to part 15 of the FCC Rules. These limits are designed to provide reasonable protection against harmful interference in a residential installation. This equipment generates, uses and can radiate radio frequency energy and, if not installed and used in accordance with the instructions, may cause harmful interference to radio communications. However, there is no guarantee that interference will not occur in a particular installation. If this equipment does cause harmful interference to radio or television reception, which can be determined by turning the equipment off and on, the user is encouraged to try to correct the interference by one or more of the following measures:

- Reorient or relocate the receiving antenna.
- Increase the separation between the equipment and receiver.
- Connect the equipment into an outlet on a circuit different from that to which the receiver is connected.
- Consult the dealer or an experienced radio/TV technician for help.

MPE caution (if an FCC certified RF module is inserted in and the separation distance is indicated in the FCC grant of RF module)

To satisfy FCC / IC RF exposure requirements, a separation distance of 8in. (20 cm) or more should be maintained between the antenna of this device and persons during device operation.

To ensure compliance, operations at closer than this distance is not recommended.

This device complies with part 15 of the FCC Rules. Operation is subject to the following two conditions: (1) this device may not cause harmful interference, and (2) this device must accept any interference received, including interference that may cause undesired operation.

L'émetteur/récepteur exempt de licence contenu dans le présent appareil est conforme aux CNR d'Innovation, Sciences et Développement économique Canada applicables aux appareils radio exempts de licence. L'exploitation est autorisée aux deux conditions suivantes :

- 1) L'appareil ne doit pas produire de brouillage;
- 2) L'appareil doit accepter tout brouillage radioélectrique subi, même si le brouillage est susceptible d'en compromettre le fonctionnement.

Any Changes or modifications not expressly approved by the party responsible for compliance could void the user's authority to operate the equipment.



CONTENT

Safety Statements.....	1
Important Information	1
Safety Symbols	1
Safety Instructions.....	2
Warranty Statement	5
Service and Maintenance	6
Service.....	6
Maintenance	6
System Overview	7
System Design	7
System Components	9
Operating Modes	14
Key Functions.....	15
System Operation	25
Startup Steps.....	25
Remote Operation and Monitoring Using FranklinWH App.....	27
Common Problems and Solutions.....	28
Technical Support	30
Emergency Response.....	32





Safety Statements

Important Information

Both the aGate and aPower are electrical devices. Please read this entire document to ensure the proper use of the FranklinWH system. Failure to follow this may void the warranty. Please strictly follow the safety instructions in this Manual during operation, otherwise it may result in equipment malfunction, electrical shock, serious injury or death.

Safety Symbols









This Manual contains the following safety symbols, as shown below.

	<p>DANGER: This indicates a hazardous situation which, if not avoided, may result in death or serious injury.</p>
	<p>WARNING: This indicates a situation where failure to follow instructions may be a safety hazard or cause equipment malfunction. Use extreme caution and follow instructions carefully.</p>
	<p>NOTE: This indicates information that is important for optimal system operation. Closely follow instructions.</p>
	<p>ELECTRONIC DEVICE: DO NOT THROW AWAY! All scrapped products (including their internal chemicals and electrical materials) should not be disposed of with household wastes. Please refer to your local laws and regulations regarding disposal.</p>

* The DANGER, WARNING, and NOTE alerts are supplemental to the safety instructions and are not exhaustive.

Safety Instructions

General Information

	The aGate and aPower are electrical equipment that, when used improperly, can present a risk of electrical shock and fire, and misuse may void the warranty. Only FranklinWH Certified Installers should install, maintain or replace aGate and aPower equipment or wiring. They must wear personal protective equipment (PPE) during operation.
	If the aPower battery is leaking electrolyte, smoking, or on fire, if it is safe to do so, disconnect the AC power from the FranklinWH system and turn off the aPower switch on the side of the aPower to stop the aPower from charging and discharging.
	It is strictly forbidden to install, maintain or handle FranklinWH equipment outdoors during bad weather such as thunder, rain, snow and high winds.
	It is strictly forbidden to work on or operate the FranklinWH equipment alone. For safety, make sure that there is someone around you who can help.
	During use, storage, and transport, ensure that the ambient temperature of an aPower does not exceed 122 °F (50 °C), that it is not near flammables, and that the cooling system and vents are not blocked.
	During the transport and handling of aGate and aPower units, extreme care is required to avoid dropping, bumping, kicking, or inverting the equipment.
	Only use parts or accessories purchased from FranklinWH or a FranklinWH-certified party.
	Do not paint any part of an aPower or aGate unless the paint surface of the equipment housing is accidentally damaged during transport, installation or maintenance. The damaged part can be repaired with paint or topcoat of the same color.
	If any equipment failure occurs, please contact your installer or after-sales service provider for support. Do not attempt to take apart, repair and/or modify an aGate or aPower without the authorization of FranklinWH. Otherwise, it may lead to safety hazards and void your warranty.



Do not use the aPower or aGate if there is functional or cosmetic damage noticed after unboxing (except for slight paint damage). Contact after-sales service for support.



The operation of the FranklinWH system requires an internet connection. Extended offline operation may result in a voided warranty. Please refer to *FranklinWH Support* for information.









Add lightning protection measures to the FranklinWH equipment according to NFPA 780, UL96A, and LPI-175.



The installation, wiring, maintenance, transportation, and handling of each aGate and aPower should follow local laws, regulations and standards, and the Safety Instructions in this Guide serve as supplementation to the laws, regulations and standards.

During use, storage, and transport of FranklinWH equipment:

	DANGER: Keep away from flammable and explosive materials.
	DANGER: Additional protective measures should be taken to protect equipment from access by children.
	WARNING: Keep away from dust and smoke.
	WARNING: Do NOT put any sundries on the top of the aPower.
	WARNING: Keep away from water sources including downspouts, sprinklers, faucets and liquid containers.
	WARNING: This product can expose you to lead, which is known to the State of California to cause cancer and birth defects or reproductive harm. (For more information go to www.p65warnings.ca.gov).

Warranty Statement

To meet warranty requirements, the FranklinWH system must be installed and operated properly according to the instructions in related FranklinWH documents.

To secure the full warranty (aGate: 12 years, aPower 1.3: 12 years, aPower 2: 15 years), the FranklinWH system must be reliably connected to the internet to access remote services provided by FranklinWH. If an internet connection is not established or is interrupted for an extended period, and FranklinWH is unable to contact you, the warranty may be limited to less than 5 years.

Please visit us at [FranklinWH Support](#) to learn more about the warranty.

Service and Maintenance

Service

- Keep leaves and other foreign materials away from the aPower batteries. Especially keep them from the top and between the units and the back wall.
- Keep the aPower away from direct sunlight.
- Keep all FranklinWH equipment in an environment with acceptable temperature and humidity.
- Clean the equipment surface using a soft cloth. If water is needed, please make sure the cloth is slightly damp (water only) and the equipment is completely de-energized.
- Don't block the vents.
- Keep all units away from flammable, explosive, and/or poisonous materials.
- Keep the equipment operating within the allowed power range and avoid overloading.
- Make sure all cables are wired reliably, and all connectors are free of stress.
- Keep the equipment away from hazardous zones and potential risks.
- A nearby smoke detector is recommended if the equipment is installed indoors.

Maintenance

- Please check the running status of your equipment on your mobile app. If an alarm is found, please contact the qualified service group.
- Please regularly check that the aPower button status is consistent with the FranklinWH App setting.
- Never attempt to repair the system by yourself. Contact the professionals qualified by FranklinWH.

System Overview

The FranklinWH system is a whole home energy solution for residential users. The two key components are the aGate, an energy management unit for whole-home power control, and the aPower, an energy storage battery with a built-in inverter. Users can monitor and operate their FranklinWH systems remotely via the FranklinWH mobile phone app.

System Design

The FranklinWH system backup options include whole-home backup and partial backup. Load selection for different options must be completed during the system design phase.

Whole-home Backup

In the whole-home backup option, all household loads, except for Smart Circuit loads, are connected via the Main Panel to the backup port of the aGate. If the grid fails, the FranklinWH system power can support all household energy loads.

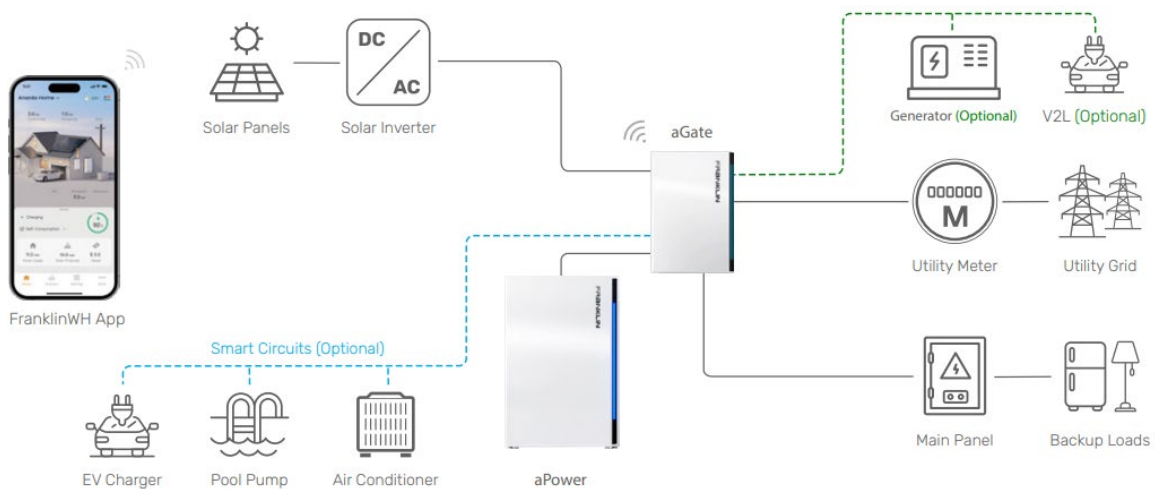

Partial Backup

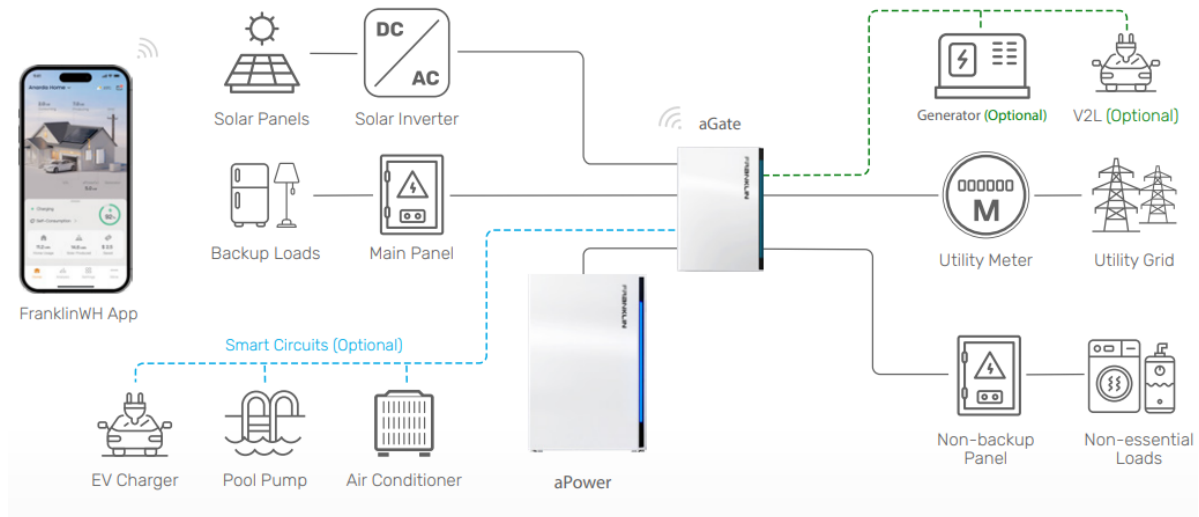

If you select a partial backup configuration, you need to identify backup loads during system configuration. Connect the backup loads (except for the Smart Circuit loads) to the backup port of the aGate, and connect the non-backup loads (non-essential loads) to the non-backup ports of the aGate. If the grid fails, the FranklinWH system will only power the backup loads during the outage.





NOTE

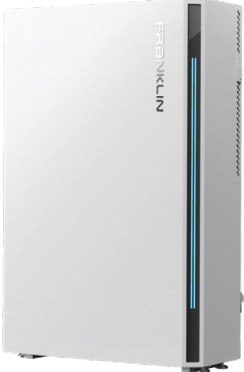

A combiner box is required for multiple aPower units' installation, except when 2 aPower units are installed with Quadplex breakers.

System Components

Component	Description	SKU
<p>aGate</p> 	<p>The aGate controls system operations with a built-in Energy Management System (EMS), power distribution and communications modules, and optional Smart Circuits and generator modules, providing power management and backup power for household loads.</p>	<p>AGT-R1V2-US; AGT-R1V3-US</p>
<p>aPower 1.3</p> 	<p>The aPower batteries store a charge provided by photovoltaic systems, the grid, or generators. They use an integrated inverter to convert AC power into stored DC, then convert the energy back to AC for use in a two-way energy flow. aPower batteries are modular, and can be scaled from a single battery to fifteen batteries controlled by a single aGate.</p>	<p>APR-05K13V1-US</p>
<p>aPower 2</p> 		<p>APR-10K15V2-US</p>

<p>aPbox (Optional)</p> 	<p>The aPbox can be used to measure the amount of electricity generated by a PV system, and can also be used as a disconnect to sever the connection to the PV system when the photovoltaic over-generation is triggered. It supports access to up to two PV systems with a total current of no more than 65A.</p>	<p>ACCY-RCV1-US</p>
<p>Split CT Kit (Optional)</p> 	<p>In some home wiring situations, the solar (PV) panels or electrical load sub-panels are connected in a way that does not allow the aGate to properly measure the power flow through the internal CTs. FranklinWH provides a Split CTs solution to aggregate the sub-panel metering into the FranklinWH system.</p>	<p>ACCY-CT200V2-US</p>

aGate Built-in Optional Parts

Component	Description	SKU
<p>Smart Circuits Module</p> 	<p>The FranklinWH system can use the Smart Circuits Module to provide homeowners with direct control of three unique circuits. The Smart Circuits Module is an optional component of the aGate.</p>	<p>ACCY-SCV2-US</p>
<p>Generator Module</p> 	<p>The FranklinWH system can connect to a household backup power generator. This connection is an optional component of the aGate.</p> <p>When the FranklinWH system is working off-grid, the generator may serve as a backup power source for the household load and to recharge the aPower. The combination of a generator and the FranklinWH system can provide uninterrupted power to homes for a long time period, lowering the fuel consumption over time of the generator.</p>	<p>ACCY-GENV2-US</p>
<p>Main Load Relay</p> 	<p>When the optional Main Load Relay is installed, the system will automatically disconnect load-side electrical appliances, so that the PV will only charge the aPower battery, significantly improving black start success rate. Without the module, you will need to</p>	<p>ACCY- MRV2 - US</p>

	<p>manually disconnect electrical appliances.</p>	
<p>Backup Expansion Lug Kit</p> 	<p>The aGate has one (1) set of backup load terminals reserved to meet the needs of most households. When there are many household backup loads, they are scattered, or when the number of connected aPowers are greater than the capacity of the aPower interface, it is necessary to group the loads or connect the excess aPowers to the backup port. The FranklinWH system provides an optional Backup Expansion Lugs to meet your needs.</p>	<p>ACCY- BLV2 - US</p>

DANGER:



- Shutting down or disconnecting a device remotely, via the FranklinWH App, does NOT mean it has been physically powered off. Therefore, any maintenance and before connecting any new load to the system, the circuit breaker on the Smart Circuits Module needs to be disconnected in advance.
- Do not touch the output ports of Smart Circuits Module directly or indirectly through conductive material, before disconnecting the circuit breakers.

NOTE



If the FranklinWH system is likely to work off the grid for a long time (e.g., due to any adverse weather condition, inspection, or intentional shutting down the grid power supply when the house is idle), it is necessary to connect the high-power devices that may automatically start up, such as an EV charger, to the Smart Circuits.

NOTE



If the Expansion Lugs are not installed, there is only one (1) pair of backup load lugs, and the circuit breaker can be added. If an Expansion Lugs is installed, the backup load port is divided into two sets of lugs, which is suitable for scattered loads, but a circuit breaker can't be added. It is necessary to install a circuit breaker in the sub-backup panel. The total current may not exceed 200A.

aGate Overview

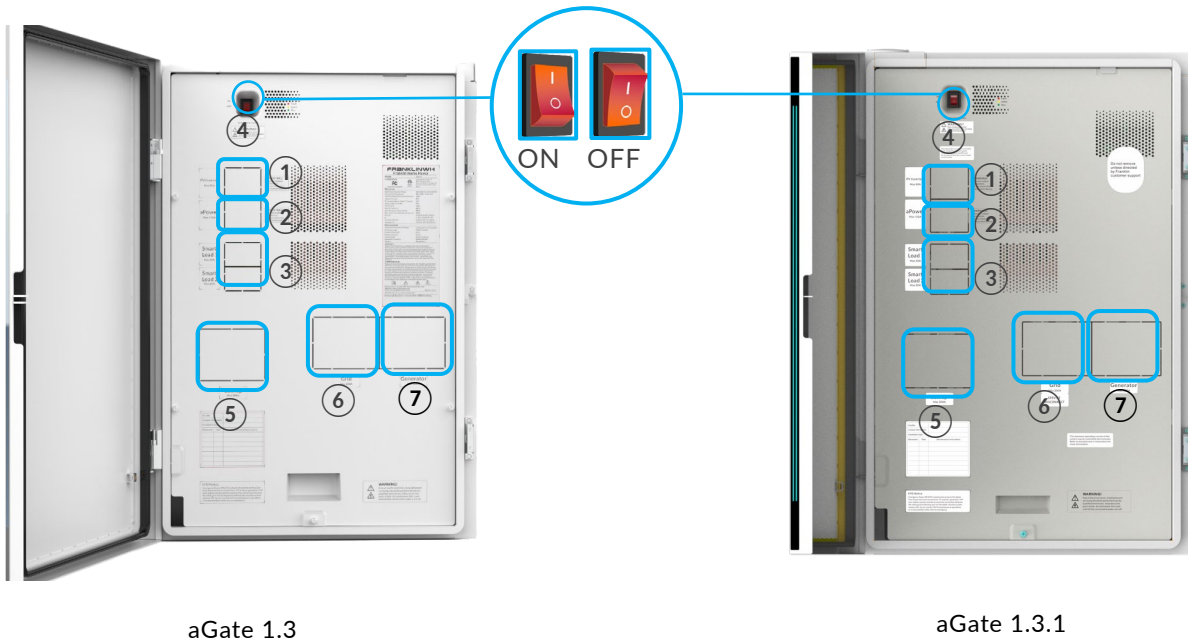

aGate 1.3

aGate 1.3.1

- ① PV Breaker
- ② aPower Breaker
- ③ Smart Circuit Breakers
- ④ aGate Power Switch
- ⑤ Backup Breaker
- ⑥ Grid Breaker
- ⑦ Generator Breaker

Note: The circuit breaker are optional parts and must be provided by the installer.

aPower 2 Overview

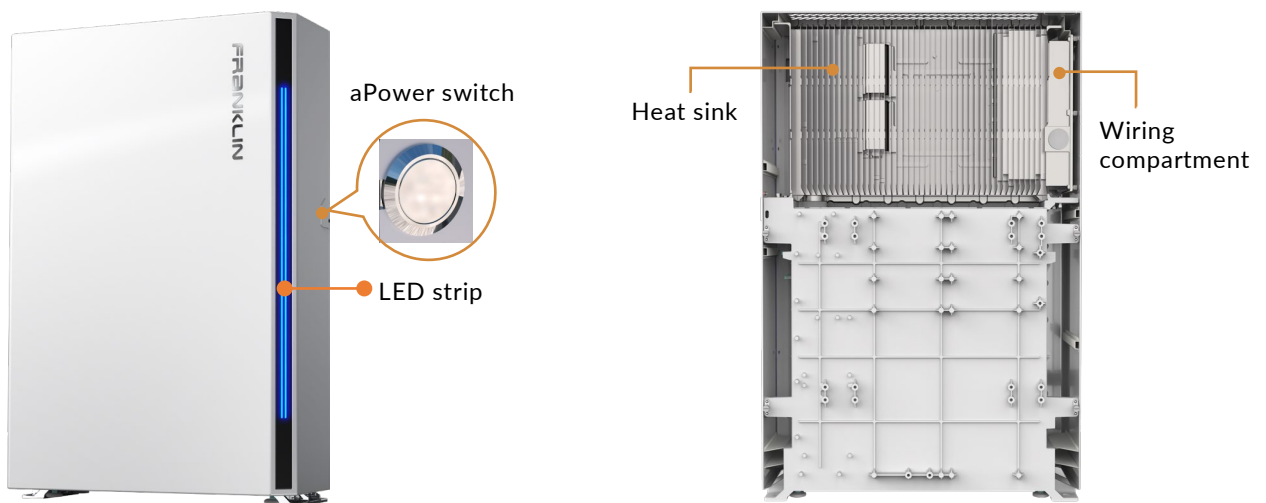

aPower 1.3 Overview

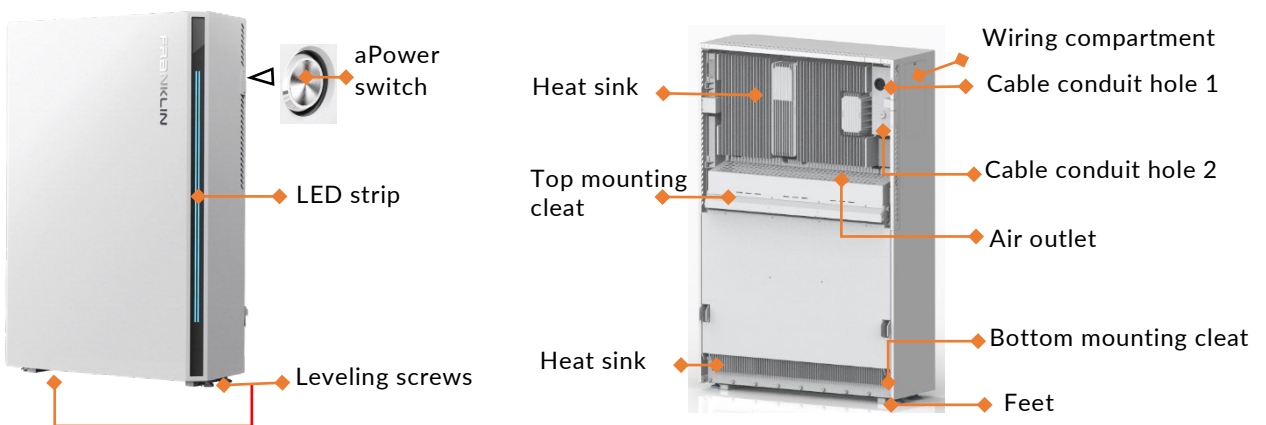

- aPower switch: Starts up or shuts off aPower power transfer.
- LED strip: Turns on when the aPower is started, indicates the battery power level.
- Leveling screws: Keeps the equipment leveled when the floor is not.
- Heat sink: Used to cool the aPower components.

- Top/Bottom mounting cleat: Must be snapped onto the mounting bracket to support the aPower body.
- Wiring compartment: The location for electric terminals and communications cable terminals.
- Cable conduit hole 1: Used to keep the power cables in position. A 1" electrical conduit may be used if the hole-plug 1 is removed.
- Cable conduit hole 2: Used to keep the signal cables in position. A ½" electrical conduit may be used if the hole-plug 2 is removed (If a signal cable hole is needed).
- Air outlet: Outlet where heat is removed, it must NOT be blocked.
- Feet: Support the aPower.

NOTE:

According to the requirements of NEC 706.15, a lockable cover needs to be added for the aPower power switch.



Users need to provide their own padlock. Please select an appropriate lock based on the lock hole diameter (d= 0.31 in. (7.87 mm)) and the available space to ensure smooth installation.

It is recommended for users to choose an outdoor waterproof lock and to keep the key secure.

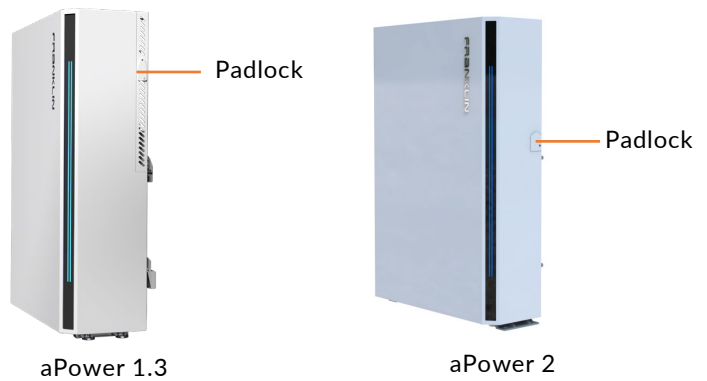

Operating Modes

The FranklinWH system supports several operating modes, including Emergency Backup, Self-Consumption, and Time of Use.

Emergency Backup Mode

When the FranklinWH system operating mode is set to the Emergency Backup, the FranklinWH system will prioritize charging the aPower battery to 100 % State of Charge (SOC) from solar and the utility grid.

In the event of a grid failure, the aPower battery will automatically power the household loads. As soon as the grid is restored, the system will automatically return to charging the aPower battery.

Self-Consumption Mode

When the FranklinWH system operating mode is set to the Self-Consumption, the FranklinWH system stores the excess electricity generated by the solar system after powering for the household loads in real-time. If the solar production is insufficient to power all the household loads, the FranklinWH system will discharge as a supportive power source, thus reducing the amount of electricity imported from the grid.

If the SOC value of the backup reserve is set 100 %, the FranklinWH system will start charging to full power (aPower battery actual SOC value = 100 %) from solar and does not discharge. In the event of a grid failure, the FranklinWH system will power the household loads.

Time of Use Mode

If the electricity rate in the homeowner's area changes throughout the day, based on demand, the homeowner can select the Time of Use mode to customize the on-peak and off-peak times according to the electricity rate. The FranklinWH system will select solar and aPower battery power during peak rate periods. During the off-peak periods, the system will use power from the grid, the PV system, and the batteries in balance according to household loads.

If the SOC value of the backup reserve is set 100 %, the FranklinWH system will start charging to full power (aPower battery actual SOC value = 100 %) from solar on off-peak period and does not discharge. In the event of a grid failure, the FranklinWH system will power the household loads.

Key Functions

Storm Hedge

When the Storm Hedge function is enabled, the FranklinWH App will receive a weather forecast from the local authority about a serious weather event, and send a warning message via the app. Then the FranklinWH system will automatically enter emergency backup mode to power household loads during the weather event. When the extreme weather passes, the FranklinWH system will automatically revert to the previous settings.

NOTE



The Storm Hedge function may be enabled under both the Self-Consumption and Time of Use modes.

Emergency Stop

In an emergency, manually turn off the external Emergency Power Off (EPO) switch, if installed. Otherwise remove the EPO plug. The FranklinWH system shuts down after the EPO is triggered.

NOTE



After the emergency shutdown, the home will lose power. When the emergency issue has passed, reset the EPO switch/plug to restore home power supply.

On-grid to Off-grid

When the grid fails or is abnormal (for example, under-voltage “brownout,” overvoltage, or abnormal frequency), the FranklinWH system automatically switches to the off-grid mode. When off-grid, the solar, generator (if connected) and FranklinWH system will power the household loads.

Off-grid to On-grid

The FranklinWH system automatically switches to the on-grid mode when the grid is restored. The grid, solar system, generator (if connected) and FranklinWH system will power the household loads.

Photovoltaic Over-Generation Protection

If the FranklinWH system is connected to the grid but is not allowed to export solar production to the grid, or when the home is off-grid, the photovoltaic over-generation protection function will be enabled when the photovoltaic output power is greater than the sum of the absorbable and load power of the FranklinWH system. The photovoltaic system will automatically be disconnected. When the photovoltaic output power is lower than the sum of the recharging power and load power of the FranklinWH system, the photovoltaic system will automatically be reconnected to the FranklinWH system.

Full Charge Protection

When the FranklinWH system is off-grid, the solar system will automatically disconnect as soon as one aPower battery in series is full (SOC = 100 %). After the FranklinWH system meets the recovery conditions, the solar system automatically connects to it and outputs power.

Black Start

When solar power is insufficient, the grid power is unavailable, and the aPower battery available power is exhausted, the Smart Circuits will be automatically disconnected and the system enters sleep mode, waiting for a black start attempt.

Automatic Black Startup

The system will automatically start at specified times every day. If the solar energy supply is sufficient, the electricity generated by the photovoltaic system will charge the aPower battery. If the solar power is insufficient, the system will re-enter sleep mode, waiting for the next automatic startup.

Manual Black Startup

When the solar energy supply is sufficient, you can manually start the system instead of waiting for the automatic black startup. Manually turn off the round button switch on the side of the aPower, turn it back on 20 seconds later, and the system will be started.

NOTE



- Repeated startup attempts may result in system lockdown. In order to increase the success rate of black startup, please make sure that the heavy electrical loads have been turned off, until the aPower is charged to 20 % SOC or higher.
 - If the grid is restored when the system is in sleep mode, the system will start immediately.
-

Smart Circuits

The FranklinWH system provides three Smart Circuits which can be controlled with the FranklinWH App based on their personalized needs. This helps minimize household expenses while on-grid and saves battery consumption while off-grid.

On-grid

Based on local peak-valley settings and personal habits (such as pumping water into the swimming pool or charging the EVs), users may set a time plan for economic power usage through the FranklinWH App. One or two time periods may be set for every 24 hours, to achieve the most economical use of electricity for Smart Circuits.

Off-grid

Users may control the on/off status of Smart Circuits by creating a time plan and setting a State of Charge (SOC) threshold. Users may set a SOC threshold (between 6 % and 100 %) based on the backup sustainability of the Smart Circuits on the FranklinWH App, where a lower SOC value means a longer backup period for the Smart Circuit. When the actual SOC falls below the set threshold, or the time is outside the time period set in the time plan, the Smart Circuit will be turned OFF. When the aPower actual SOC rises above the threshold, the aGate will reconnect with the Smart Circuit.

The Smart Circuits will not be reconnected until the aPower actual SOC is 5 % higher than the SOC threshold. For example, if the SOC threshold is set to 25 %, regular backup loads will be connected when the SOC reaches 25 %, but the Smart Circuits will not be reconnected until the SOC reaches 30 %.

Manual Control

Users may control the on/off status of the Smart Circuits through the FranklinWH App. The manual control of the Smart Circuits on/off status has higher operation priority, so that the current time schedule can be overridden, disabled, and reactivated in the next time period.

The Smart Circuits Module can remotely control the on/off status of three Smart Circuits, which may be set and controlled separately. Smart Circuit 1 and Smart Circuit 2 may be set flexibly based on user needs and the configuration on the FranklinWH App, choosing two 1-pole breakers or one 2-pole breaker, while Smart Circuit 3 must work with one 2-pole breaker. Smart Circuit 3 is only used for 240V loads without neutral wire. No device requiring a neutral wire should be connected to Smart Circuit 3.

Generator compatibility

The aGate connects the generator module with the FranklinWH App to provide an intelligent generator-based power backup system. The FranklinWH system supports Manual and Auto mode configuration parameters.

Auto Mode

In Auto Mode, generator access and disconnection can be controlled by a preset state of charge (SOC) value or can be controlled intelligently by setting up the time periods.

SOC Control

The generator will be activated automatically when the FranklinWH system is working in off-grid mode and after battery SOC falls below the set level (20 % default. Adjustable between 10 % and 80 %). The system will activate the generator to power the load, with the surplus power generated sent to charge the aPower.

When there is power supply from the grid or the FranklinWH system battery level reaches the upper SOC (80 % default, adjustable 20-100 %), the generator will be automatically shut off and other sources will power the loads.

Charging Schedule

Based on their own habits, users may set up a charging schedule through the FranklinWH App for the time periods when power supply from the grid is interrupted. The settings allow up to three non-overlapping time periods in a single calendar day. Once the charging schedule is enabled, when the generator is activated to power the loads, it also charges the aPower. When the charging period ends, the generator will be shut off.

Manual Mode

When the power supply from the grid is interrupted, users may manually start/shutdown the generator. For example, when a power outage occurs, the user may start the generator manually before leaving, to charge the FranklinWH system in advance, and may shut off the generator via the app before they return home, so that the FranklinWH system will take over as the power source. This helps to manage the noise produced by the generator, so that customers may enjoy a quieter home environment.

Vehicle to Load (V2L)

With a Generator Module installed, the aGate unlocks versatile V2L functionality, allowing users to power home appliances directly from the vehicle's battery in emergency situations, which is literally compatible with any 240 V V2L EV model.

**NOTE: The support is currently limited to the Ford F-150 Lightning. The expansion of compatibility to include additional electric vehicle (EV) brands and models is expected to be announced.*

aPbox Application

While the aGate has a PV breaker as an optional component, there are some situations in which the PV system cannot be connected through the breaker or where there are multiple PV connections needed. In those instances, an aPbox can be used to connect the solar source to the aGate or the grid.

There are two scenarios that define how the external connections with an aPbox are connected.

PV on the load side of the FranklinWH system

Installation of an aPbox is required to meter the production of and cutoff the connection to an individual PV system installed on the load side of the FranklinWH system due to:

- Existing constraints, such as the location of the PV system and the aGate, preventing the PV system connection to the aGate internal PV interface.
- Multiple PV systems on-site prevent a distinct PV system from being connected to the aGate.
- The total PV system output power exceeds the power rating of the aGate internal PV interface.
- The total amount of the PV production exceeds the aPower energy capacity.

One aGate supports up to two aPbox connections on the load side. The FranklinWH system controls the PV system connection according to whether the photovoltaic over-generation in the off-grid mode.

PV on the line side of the FranklinWH system

The installation of an aPbox is to monitor the generation of the PV system and provide data to the FranklinWH system.

In this scenario, one aGate only supports one aPbox connection.

NOTE



When there is a grid outage, the line side separated PV system will disconnect from the grid and shut down.

PV on the aGate Solar Meter Upstream

When the total amount of power generated by the PV system installed upstream of the aGate solar meter exceeds the aPower energy capacity, connecting the PV system directly to the aGate internal PV interface may result in exceeding the feeder limit in on-grid mode or the photovoltaic over-generation in off-grid mode. In this scenario, installing an aPbox in front of the aGate PV interface can split the output line of the PV system into two, one of which passes through the aPbox and then connects to the aGate PV interface.

When the PV system output power is too high, the aGate can control the aPbox to disconnect one PV input to reduce the PV power connected to aGate. The benefit of this is that the FranklinWH System can avoid directly cutting off the operation of the entire PV system and ensure that the PV system can continue to be used normally.

Heating blanket (Cold temperature performance)

The operating temperature range for the aPower 2 and aPower S is -4° F to 122° F (-20° C to 50° C). The aPower unit is rated IP67 and designed for both indoor and outdoor installation. Low cell temperatures impact charging performance more significantly than discharge performance. Each aPower 2 and aPower S unit includes an integrated 380 W heating blanket (2 × 190 W), optimized to support performance across the wide temperature range.

This enables dependable operation in outdoor installations, even in harsh environments, without compromising efficiency. The heating blanket helps mitigate temperature-related deration by maintaining optimal cell temperatures. For regions with prolonged extreme cold, indoor installation is recommended to maximize performance.

LED Light Strip Color Settings (for aPower 2)

You can customize the color and brightness of the LED light using the FranklinWH App.

Download FranklinWH App and sign in with your FranklinWH account, then go to **Settings > aPower LED**.

- **LED switch:** Turn on or off the LED lights of all the aPowers in parallel.
- **Light-on schedule:** Schedule a time period to turn on the LED lights. (The time period must be less than 24 hours.)
- **LED settings:** Adjust the color and brightness of the LED lights. The default color of the LED lights is blue.



The 42 LED beads of the light strip indicate the SOC ranging from 0% to 100%, lighting up in a bottom-to-top sequence.

Status	LED light behavior	Descriptions
Charging	Slow breathing	$5\% < SOC \leq 100\%$: The LEDs breathe at a 10 second cycle proportionally to the SOC.
Discharging/ Standby	Solid on	$5\% < SOC \leq 100\%$: The LEDs are illuminated in proportion to the SOC.
	Flash	$SOC \leq 5\%$: The last two LEDs flash at a 2.5 second cycle. The remaining LEDs are off.
Sleep	Off	All the LEDs are off.
Error	Fast breathing	All the LEDs breathe simultaneously every second.

LED Light Strip Lighting (for aPower 1.3)

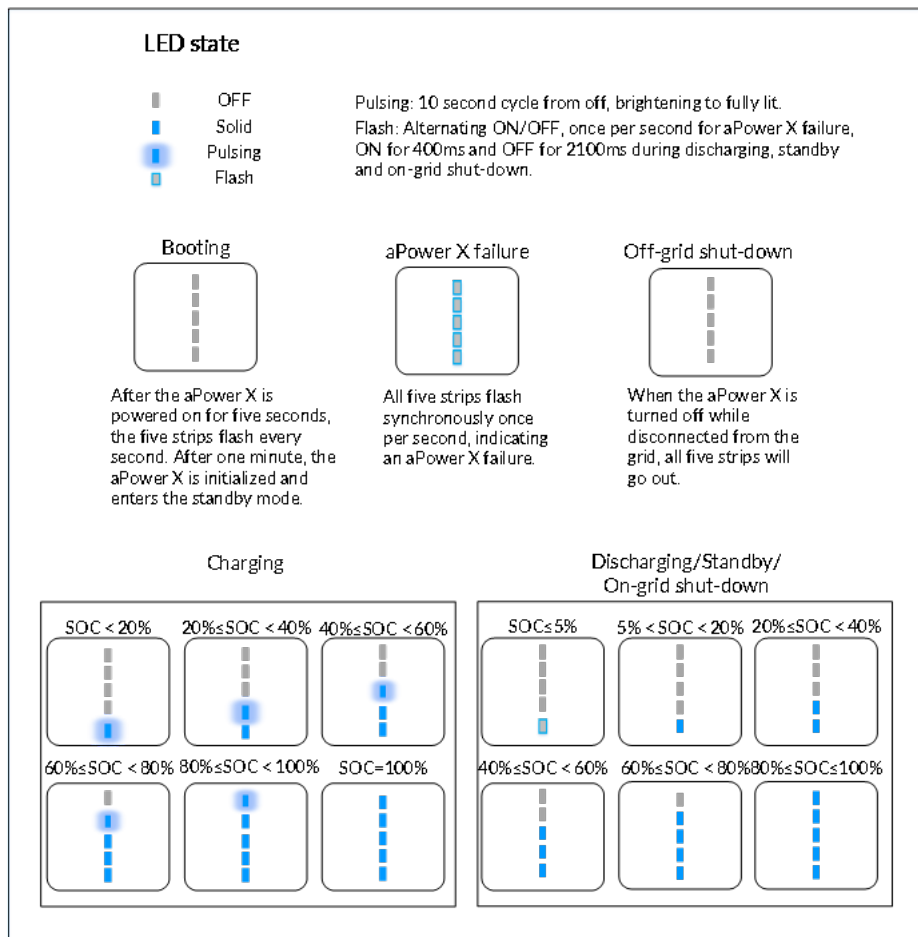
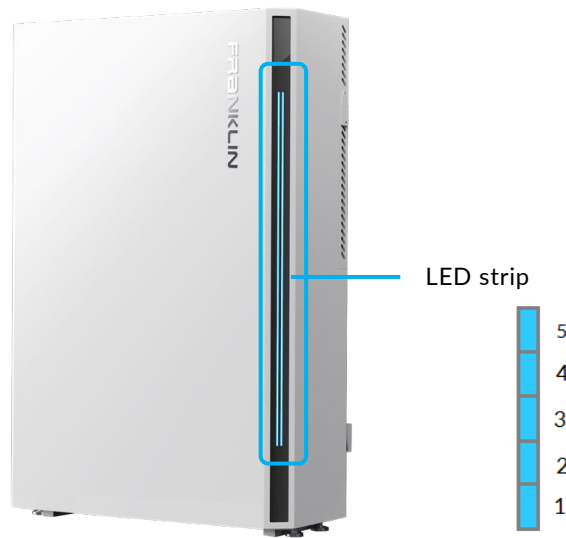

Fault Recording

The software records real-time voltage and current data in the RAM for a specific duration. In case of a fault, the RAM data is securely stored in flash memory, ensuring that voltage and current waveform data can still be retrieved both before and after the fault, even if the load has been powered off.

Multiple Power Setting Options(for aPower 2 only)

In on-grid mode, the rated power of a single aPower can be configured. The available options are: 10 kW, 9.6 kW, 7.6 kW, 5 kW.

System Operation

The FranklinWH system can be operated locally or remotely, but local operation is preferred for maintenance and inspection. It is recommended that the FranklinWH system be restarted and maintained locally. During maintenance or inspection, local operation must be used to ensure circuit safety.

Startup Steps

1. Ensure that the grid breaker, the generator breaker, the backup breaker, and the solar breaker are all in the OFF position (for initial use).
2. Ensure that the aGate power switch on aGate is in the ON position.
3. Turn on the aPower breaker.
4. Press the aPower switch to ensure that the switch is on. When the aGate power switch indicator on the aGate lights up, wait until the bottom of the LED strip on the aPower lights up, which indicates that the aGate is successfully powered without connecting to the grid.
5. After about 60 seconds, the photovoltaic relay turns on automatically. If the aPower has power output, that indicates that the aPower has successfully started without connecting to the grid.
6. If the grid is normal, turn on the aGate grid breaker. After the grid relay is turned on, the grid icon  on the FranklinWH App homeowner home screen will light up, indicating that the aPower is successfully connected to the grid.
7. Turn the generator breaker (if the Generator Module is installed) and solar breaker to the ON position.
8. Turn on the Smart Circuit breakers (if the Smart Circuits Module is installed), the backup breaker and the breakers in the load panel.

NOTE



The initial startup process includes steps 1 to 8, while the general restart process is as follows: turn off the aGate power switch and the aPower switch, wait for 5 seconds after the LED strip on the aPower goes out, then turn on the aGate power switch, and follow the instructions in steps 3 to 8.

Shutdown Steps

1. Turn off the grid breaker if connected to the grid.
2. Press the aPower switch on all aPower batteries to the OFF position (extended, flush with the case), and each LED strip will go out.
3. Turn off the aPower breaker.
4. Turn off the PV breaker.
5. Turn off the generator breaker if connected to a generator.
6. Turn off the Smart Circuits and backup breakers if applicable.
7. Turn off the aGate power switch inside the aGate.

NOTE



If the family plans to be gone for a long time, please keep the grid or PV power, aPower breaker, aPower switch and aGate power switch on. Otherwise, the energy stored in aPower will eventually be depleted, resulting in a startup failure.

Remote Operation and Monitoring Using FranklinWH App

The FranklinWH App provides remote operation and monitoring of the whole house energy system at anytime from anywhere. It allows personalized household electricity plans to make your life easier.

The home screen of the FranklinWH App displays real-time data from the FranklinWH system to help you understand the working status of your home power system. Please refer to the *Energy Data* at <https://www.franklinwh.com/support/overview/energy-data> for more information.

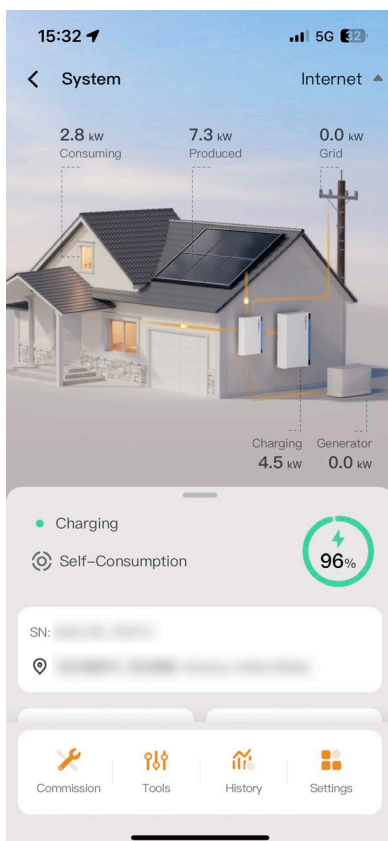

***Note:** If the generator is disabled, the generator icon will not appear.

Common Problems and Solutions

No.	Problems	Solutions
1	aPower LED on the aPower keeps flashing once per second.	<p>Check if the aGate EMS module is working normally:</p> <ul style="list-style-type: none"> i. Check that the aGate power switch is ON (closed) and the indicator is lit. ii. Check if the aGate is connected to an external EPO (Emergency Power Off) switch. If yes, check that the EPO switch is closed. iii. Check that the aPower breaker on the aGate is in the ON position.
2	aPower starts off-grid and fails to discharge.	<p>Check whether the aPower breaker on the aGate is in the ON position. If not, flip it on and then check the aPower status after 1 minute. If aPower discharges properly, the equipment is back to normal.</p>
3	After startup, the aGate failed to activate the Wi-Fi access point (AP).	<p>Turn off the aGate power switch and turn it on after 10 seconds. Scan for the aGate hotspot on your mobile phone. If your mobile phone is connected to it, the Wi-Fi access point has returned to normal.</p>
4	"Device offline" is displayed on mobile app.	<p>Check whether the aGate communication network is normal:</p> <ul style="list-style-type: none"> i. If the aGate is communicating via hard-wired ethernet, please check the network connectivity. ii. If the aGate is communicating via Wi-Fi, please check the signal strength. The aGate does not currently support 5GHz Wi-Fi network connection. Please ensure that a 2.4GHz Wi-Fi network is available. iii. If a 4G cellular network is used, please check the network conditions at the aGate location. If the signal strength is poor, contact your installer to purchase a 4G cellular network enhancement option.

No.	Problems	Solutions
5	A prompt of “Low battery, black start attempts” is displayed on the mobile app.	<p>Check whether the grid power is down and whether the solar system is out of operation or there is insufficient sunlight.</p> <ul style="list-style-type: none"> i. Low battery and black start indicate that the battery capacity is very low, the backup power and auxiliary power will be disconnected, and the system will enter sleep mode. Once the system enters sleep mode, it will automatically recover and charge the batteries the next day if there is sufficient sunlight. ii. By default, the system black start times are approximate 10:00, 12:00 and 14:00. There may be some deviations in time in sleep mode. iii. During black start, please turn off all household loads to ensure that FranklinWH system can be started normally. iv. Manual black start is also an alternative to automatic. Manual Start: Turn off the aPower switch on the side of aPower (extended, flush with case), and turn it back on (depressed) 20 seconds later. The system will start up. v. Black start will consume the reserve capacity, it is recommended to attempt a manual start only when there is enough solar production. Otherwise, the system may lock.
6	A prompt message of “Black start failed” is displayed on the mobile app.	<ul style="list-style-type: none"> i. Check if there are household electrical devices running when the system attempts to start. Ensure that all the household electrical devices are shut down, to help the system successfully start. ii. Check whether the solar system is operating normally and whether there is sufficient sunlight.

No.	Problems	Solutions
7	"Off-grid overload" is displayed on the mobile app.	<ol style="list-style-type: none"> i. Check if the grid is available. ii. Check if there are large electrical devices running. If yes, shut down the unessential devices to allow the system to operate normally. iii. Due to the special characteristics of the battery, the system power is slightly reduced at temperatures below 50 °F (10 °C) to guarantee the service life of the battery. If an off-grid overload occurs in this case, shut down the large electrical devices to allow the system to operate normally. iv. If the system experiences an off-grid overload during multiple aPower units starting, turn off all electrical devices and turn them back on in sequence after the aPower units have been successfully started.
8	The system shuts down after an air conditioner or a pump is started.	<ol style="list-style-type: none"> i. Check if the grid is available. ii. During a grid outage, due to the power required to start the air conditioner or pump, the system may shut down while other large electrical devices are running when trying to start the air conditioner or pump. Because of this, it is recommended that you shut off other large electrical devices and restart them after the air conditioner or pump has been successfully started.

Technical Support

For further support, please contact the installer or FranklinWH service team at: [FranklinWH Support](#). Please be prepared to provide the following information before you contact FranklinWH:

- Owner name
- Your preferred desired contact method (name, phone number, email)
- The serial number of your aGate and aPower
- A brief description of your problem

aGate X serial number

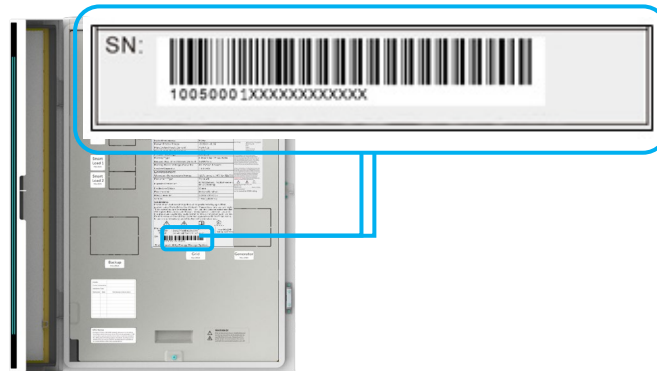

aGate 1.3

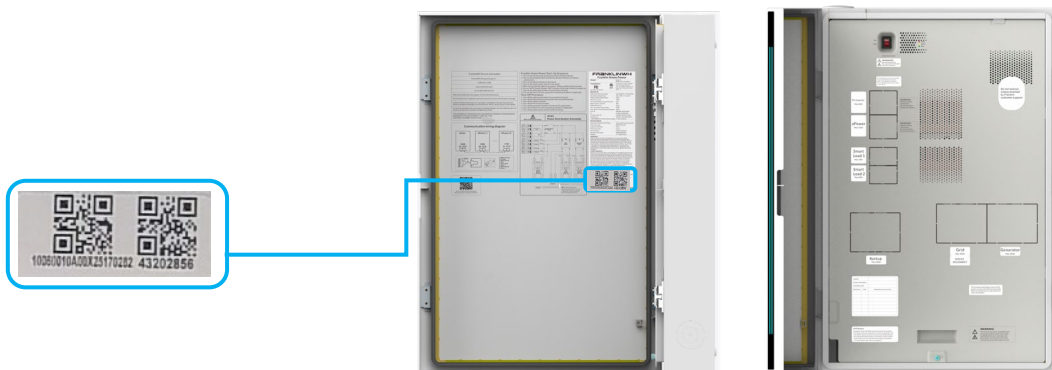

aGate 1.3.1

aPower 1.3 serial number

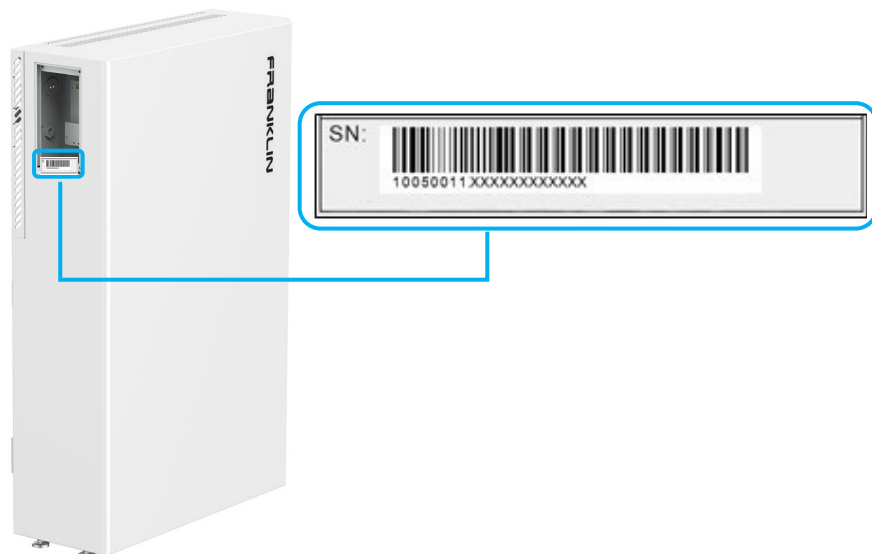

aPower 2 serial number

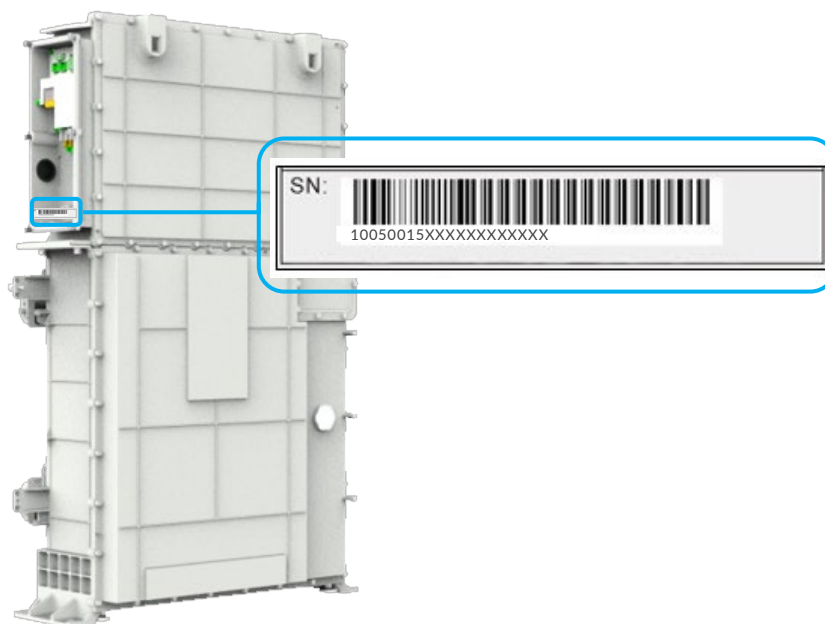

Emergency Response

In any hazardous situation that may damage health and cause serious injury, follow the recommended actions:

- Evacuate to a safe area.
- Contact 911 as soon as it is safe to do so.

In case of fire

- Shut off the aPower breaker on the aGate, when it is safe to do so.
- Evacuate to a safe area.
- Contact 911 as soon as it is safe to do so.
- Use approved fire extinguishing devices, if it is safe to do so.

In case of flooding

- If the wiring sections of an aGate or aPower are submerged, please keep away from the water. It is an electrocution hazard.
- Drain the water to protect your FranklinWH equipment, if it is safe and possible.

- If water reaches the battery, please call your installers for an inspection. If the water level is below the battery, please completely dry the site and your FranklinWH equipment before use.

In case of abnormal noise, odor or smoke

- Check to ensure the air vent of the aPower is not blocked.
- Keep the installation site well ventilated.
- Call your installer for support.

Appendix: Revision History

REVISION	DATE	DESCRIPTION
V1.0.1	April 30, 2026	Updated the heating blanket feature
V1.0	December 30, 2024	Initial release