



FranklinWH System Installation Guide

Version 1.2.07

©2026 FranklinWH Australia Pty Ltd. All rights reserved.

All information in this Manual is subject to the copyright and other intellectual property rights of FranklinWH Australia Pty Ltd. This manual may not be modified, copied or reproduced, in whole or in part, without the prior written permission of FranklinWH Australia Pty Ltd.

Please visit [FranklinWH Support](#) for the latest FranklinWH documents.

All brands and trademarks mentioned in this document are the property of their respective owners, and their use in this document does not imply the sponsorship or recognition of their products or services.

Please read this document carefully to ensure the best reliability of the product and your warranty eligibility. For further information about warranty, please refer to the **FranklinWH Limited Warranty**.

This document is intended for use by professional installation and maintenance service providers only and no statements, information or recommendations in this document constitute any express or implied warranty.



Please read this document carefully before installing or using the FranklinWH equipment. Failure to follow any instructions or warnings in this document may result in damage to the equipment, personal electric shock, severe injury, or even death.

Product Information

The FranklinWH system is composed of aGate, aPower, and other electrical and software components.

FranklinWH Australia Pty Ltd. ("FranklinWH") reserves the right to make any improvements to the product, and the contents in this document shall be subject to updates without further notification.

All images and pictures provided in this Manual are only for demonstration purposes and may differ in detail from the product, based on the product version.

Feedback

If you have any questions or comments, please send us an email at: service-au@franklinwh.com

Disposal of Scrapped Products

Scrapped products (including their internal chemicals and electrical materials) should not be disposed of with household wastes. Please refer to your local laws and regulations regarding disposal. These certification labels are for information only.



CONTENT

Safety Statements	1
Safety Symbols	1
Safety Instructions for Operation	2
Safety Instructions for Installation Site.....	5
Fire and Other Emergency Situations	7
FranklinWH System Overview	8
Whole-Home Backup System	8
Partial Backup System	9
Installation Preparations	10
Site Planning	10
Tools.....	15
Materials	17
Installation	19
Moving.....	19
aPower Installation.....	19
Unboxing and Transporting the aPower	19
Mount the Bracket	21
Drill Cable Inlet Holes on The Wall (if needed).....	28
Mount the aPower in the Bracket	30
Adjust the Floor Mounted aPower Level	32
aGate Installation.....	33
Unbox the aGate.....	33
Remove the Door and Inner Panel from the aGate	34
Prepare aGate Cable Inlets.....	36
Enlarging or Drilling New Holes (if necessary).....	37
Install Optional Module(s)	38







Install Breakers as Needed	47
Mount the aGate on the Wall	50
Electrical Conduits and Wiring.....	54
Electrical Conduits.....	54
Communications Wiring.....	57
Electrical Wiring.....	64
Completing Installation.....	80
Re-Install the aPower Wiring Compartment Cover and Install Grilles.....	80
Re-Install the aGate Door and Inner Panel	81
Appendix 1: Electrical Parameters.....	83

Safety Statements











WARNING: This Guide includes important information about the FranklinWH system. Please read this Guide carefully before installation, maintenance or use. Failure to follow any instruction in this Guide may lead to risks of equipment damage, electric shock, severe personal injury and even death, and may also void the warranty ([FranklinWH Support](#)).













The DANGER, WARNING, and NOTE alerts are supplemental to the safety instructions and are not exhaustive.





Safety Symbols

	<p>DANGER: This indicates a hazardous situation, which if not avoided, could result in serious injury or death.</p>
	<p>DANGER: There are fire risks in the battery packs.</p>
	<p>WARNING: This indicates a situation where failure to follow instructions may be a safety hazard or cause equipment malfunction. Use extreme caution and follow instructions carefully.</p>
	<p>NOTE: This indicates information important for optimal system operation. Follow instructions carefully.</p>
	<p>PROTECTIVE GROUNDING TERMINAL: This indicates the position of grounding connection on the equipment.</p>
	<p>WAIT TIME: It means there are electric shock risks inside the equipment, please wait 5 minutes before proceeding.</p>
	<p>ELECTRONIC DEVICE: DO NOT THROW AWAY. Scrapped electronic products and batteries cannot be disposed of together with household wastes. Please consult your local laws and regulations for further information.</p>











Safety Instructions for Operation





	<p>DANGER: The installation, wiring, maintenance, transportation, and handling of each aGate and aPower should follow local laws, regulations and standards, and the Safety Instructions in this Guide serve as supplementation to the laws, regulations and standards.</p>
	<p>DANGER: Before any electrical operation starts, please turn off the grid power supply switch, generator input switch, the solar input switch, the load switch, and lock the switches. If the switches cannot be locked, please lock the distribution box where the switches are installed. A warning sign Out of Operation, Do NOT Turn On should be hung.</p>
	<p>DANGER: Both aPower and aGate are electrical equipment, and improper operation may lead to electric shock, energy hazards, or chemical hazards. Please do NOT open the cabinet or disassemble without express direction from the FranklinWH service team.</p>
	<p>DANGER: Only FranklinWH certified and qualified technicians can install, maintain or replace aGate and aPower equipment or wiring. They must wear personal protective equipment (PPE) during operation.</p>
	<p>DANGER: It is strictly forbidden to work on or operate the system alone. For safety, make sure that there is someone around you who can help.</p>
	<p>DANGER: It is strictly forbidden to install, maintain, or handle the system outdoors during bad weather conditions, such as lightning, thunder, rain, snow, or strong winds.</p>
	<p>DANGER: In case of a battery fire, please take actions as instructed in the Safety Data Sheet.</p>
	<p>DANGER: The aPower must be carefully handled and installed using lifting equipment to avoid injury to installers or the aPower.</p>
	<p>DANGER: During the transport and handling of aGate and aPower units, extreme care is required to avoid dropping, bumping, stomping, or inverting the equipment. To prevent potential damage, please keep all aPower units in their packaging until ready to install.</p>
	<p>DANGER: During use, storage, and transport, ensure that the ambient temperature of an aPower does not exceed 50 °C, that it is not near flammables, and that the cooling system and vents are not blocked.</p>

	<p>DANGER: Do not attempt to take apart, repair and/or modify an aGate or aPower without the authorization of FranklinWH. And it is prohibited to open the battery pack chamber in any situation. Otherwise, it may lead to safety hazards and void the warranty.</p>
	<p>DANGER: To prevent accidental operation, ensure that the upstream and downstream switches are disconnected and padlocked during installation or maintenance.</p>
	<p>DANGER: If an aPower or aGate is found damaged (except for minor defects in exterior painting) after it is unboxed or malfunctioning on installation, please do NOT operate it and contact your after-sales service provider for support.</p>
	<p>DANGER: Before any installation and commissioning of an aPower, please keep the round switch button on the right part of aPower off (extended, flush with the case) and prevent the ON/OFF switch from being operated by mistake.</p>
	<p>DANGER: If the aPower battery is leaking electrolyte, smoking, or catching fire, if it is safe to do so, please disconnect the AC power from the FranklinWH system, and turn off the aPower switch to stop charging and discharging the battery.</p>
	<p>DANGER: The installation of FranklinWH system must comply with all applicable requirements of AS/NZS4777.1 and AS/NZS5139.</p>
	<p>DANGER: Both electric connection and electric isolation need to comply with the local standards and AS/NZS 3000, AS/NZS 4777.1.</p>
	<p>DANGER: The installer needs to provide suitable conduits and cables, and complete the installation process in accordance with the local regulations.</p>
	<p>WARNING: For maintenance purposes, do NOT use any parts or fittings that are not listed in this Guide or that are purchased from any source other than FranklinWH or its recognized dealers.</p>
	<p>WARNING: Measures should be taken to prevent foreign objects from entering any aPower or aGate.</p>
	<p>WARNING: Do NOT use paint on any part of an aPower or aGate, whether internal or external, especially on the protective cover except for exterior paint that has been worn out or damaged in the transportation, installation, or maintenance process. The damaged part can be repaired with paint or topcoat of the same color.</p>
	<p>WARNING: Do NOT connect an aPower directly to the solar inverter.</p>

	WARNING: Before installation, do not place an aPower on site for more than one month. After installation, do not turn on the aPower before connecting the PV and grid, otherwise the battery will be depleted due to a long period of time without charging.
	WARNING: FranklinWH system is composed of an aGate, and one or more aPower units, and other electrical components which cannot be used separately.
	WARNING: An aPower may only be connected to the aPower breaker on the aGate.
	WARNING: The inputs from grid and generator may only be connected to the respective reserved terminals on the aGate.
	WARNING: The operation of the FranklinWH system requires an Internet connection. Extended offline operation may result in a voided warranty. Please refer to FranklinWH Support for information.

Safety Instructions for Installation Site

	DANGER: The installation site of aPower and aGate units should be protected from access by children, or additional protective measures should be taken to protect the FranklinWH equipment from misoperation and contact by children.
	DANGER: The installation site of aPower and aGate units should be kept away from heating devices, or any source of heat and/or fire.
	DANGER: The aPower and aGate installation area should be well-ventilated to maintain the ambient temperature between -20°C and 50°C and the relative humidity between 5 % and 100%. The altitude should be lower than 4,000 m. If an aPower or an aGate is to be installed in a confined area, forced ventilation must be in place.
	DANGER: The aPower and aGate installation area should be protected from flooding and standing water.
	DANGER: The aPower and aGate installation area should be away from flammable and explosive materials.
	DANGER: Where the installation site for an aPower is internal to a structure, consideration should be given to adding a suitable fire detection device in the vicinity of the installation that meets the Standards and interconnecting this device to the existing Home Fire Detection Systems
	WARNING: Before the installation starts, engineers should check and locate the embedded electric wires and water pipes to avoid potential property damage and personal injury during the installation process.
	WARNING: aPower units may be installed on the floor or on walls, a floor installation is recommended. If wall-mounted, the wall should be able to provide sufficient bearing capacity.
	WARNING: The aPower and aGate installation area should be protected from dust and smoke.
	WARNING: The aPower and aGate installation site should be protected from direct exposure to sunshine, and snow.
	WARNING: The aPower and aGate installation site should have no water source above it or in the vicinity, including water pipes, shower, faucet, and containers of liquids.

	WARNING: The installation site should be properly leveled and hardened if the aPower is floor mounted. If there is grass nearby, a layer of cement or slab stone must be placed on the projection area of the equipment to block grass growth and prevent the equipment from collapsing.
	WARNING: Do NOT clean aPower and aGate units with cleaning agents or expose them to flammable or irritant chemicals or their vapors.
	WARNING: The noise factor (< 45 dB) must be taken into account when selecting the installation site for each aPower. Selection of the site must involve consent of local residents.
	WARNING: It is required that internet connectivity is provided at the aGate installation site. A hardwired connection is more reliable but Wifi and 4G connections are possible.

Fire and Other Emergency Situations

Fire:

- Shut off the aPower breaker on the aGate, if it is safe to do so.
- Evacuate to a safe area.
- Contact Emergency Services as soon as it is safe to do so.
- Use approved fire extinguishing devices, if it is safe to do so.

Flood:

- Shut off the aPower breaker on the aGate, if it is safe to do so.
- If the wiring sections of aPower or aGate are submerged, please stay away from the water. Electric leakage may result in electric shock.
- Drain the water to protect the system, if it is safe and possible.
- If water rises to the battery level, please call your installers for inspection. If water level is below the battery chamber, please allow the site to completely dry.

Abnormal noise, odor or smoke:

- Shut off the aPower breaker on the aGate, if it is safe to do so.
- Check and ensure your aPower is well ventilated and not blocked.
- Keep the installation site well ventilated.
- Call your after-sales service for support.

FranklinWH System Overview

FranklinWH system is a whole-home energy solution for residential users. The two key components are the aGate, an intelligent power management unit for whole home power control, and the aPower, an energy storage battery unit with built in battery management system (BMS) and inverter. Users can monitor and operate their systems remotely via the FranklinWH App. With AC coupling and energy management technologies, the FranklinWH system provides a reliable household backup and load control solution for homes.

The FranklinWH system backup options include whole-home backup and partial backup. Load selection for different options must be completed during the system design phase.

The aPower stores energy from the grid, solar systems and generators, and can power the home during grid outages, during peak rate periods, or at night (for solar self-generation).

Whole-Home Backup System

In the whole-home backup system, all household loads, except for Smart Circuit loads, are connected via the Main Panel to the backup port of the aGate. If the grid fails, the FranklinWH system power can support all household energy loads.

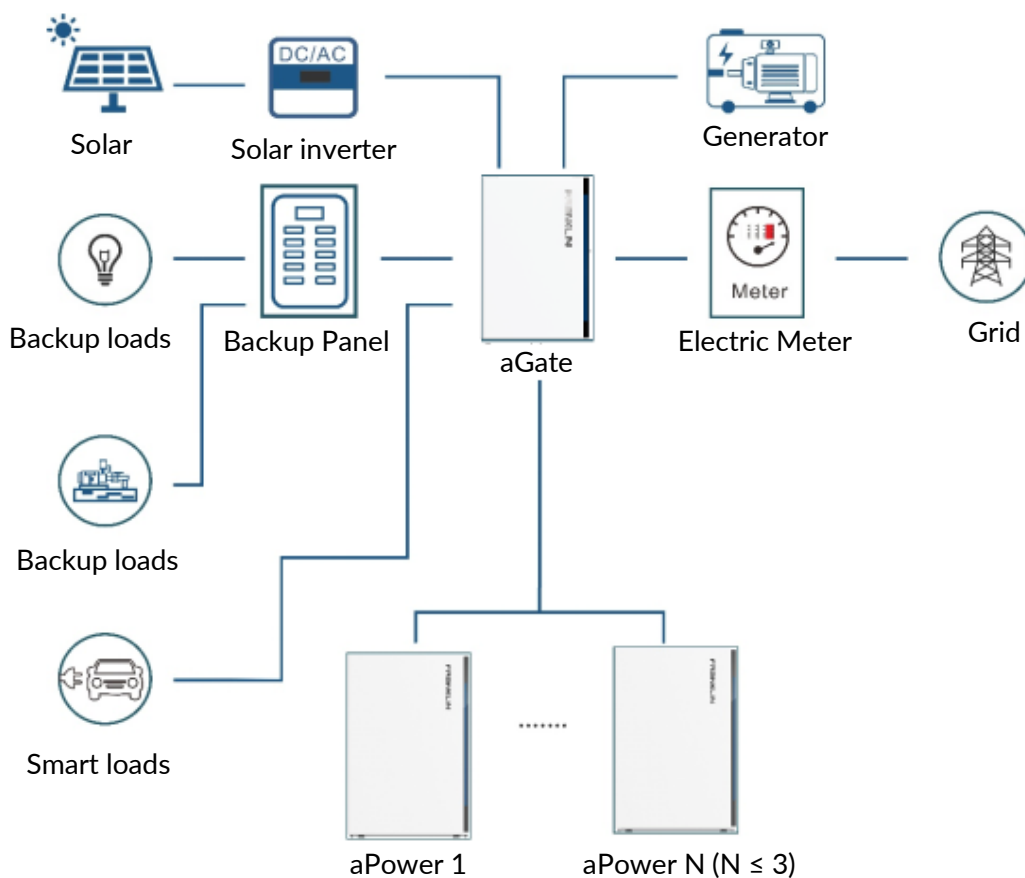

Partial Backup System

If you select a partial backup configuration, you need to identify backup loads during system configuration. Connect the backup loads (except for the Smart Circuit loads) to the backup port of the aGate, and connect the non-backup loads to the non-backup ports of the aGate. If the grid fails, the FranklinWH system will only power the backup loads during an outage.

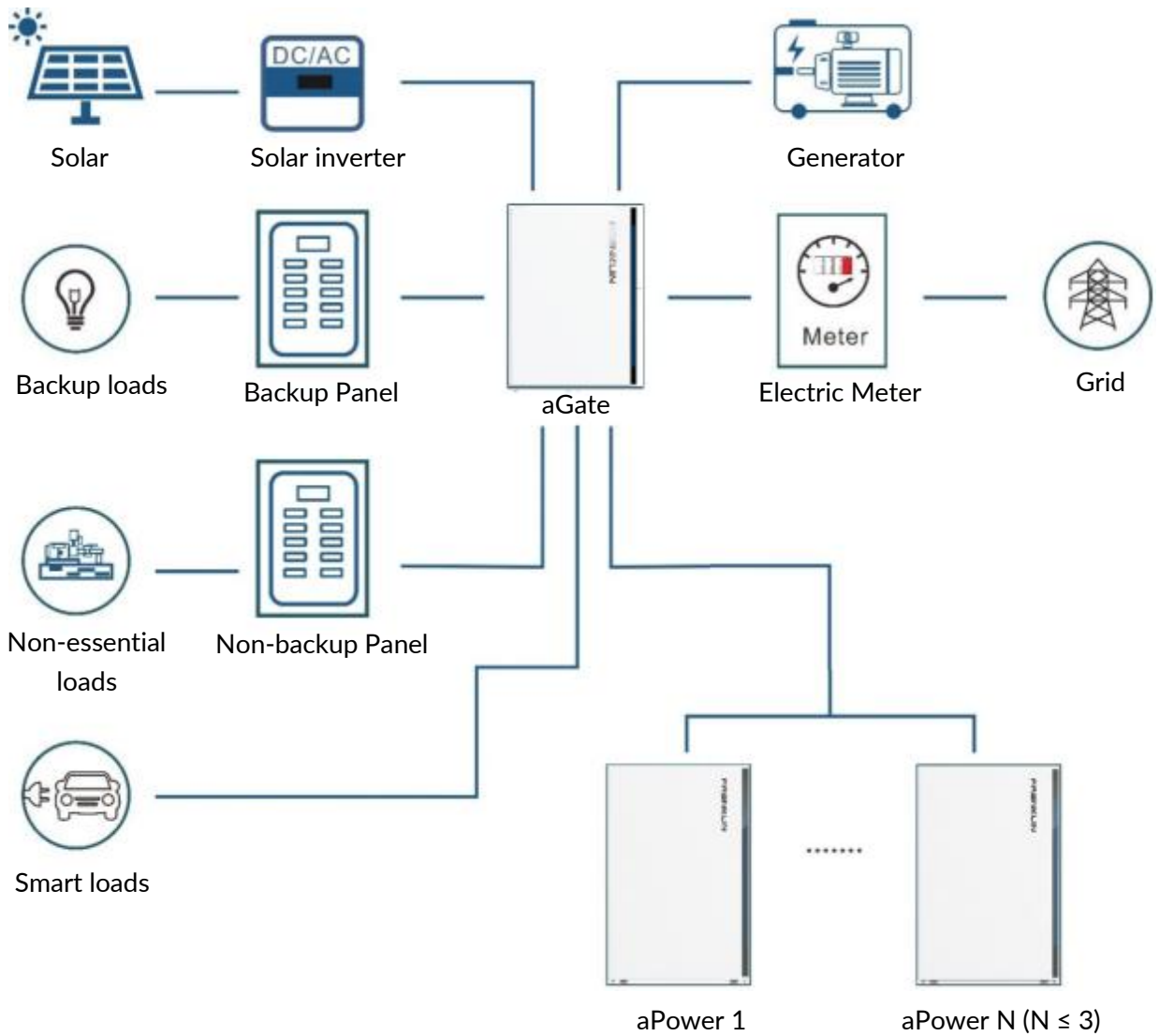

Installation Preparations

Site Planning

Plan installation position

NOTE:



The selection of installation location must avoid water and power conduits. Refer to all applicable local codes and standards.

- The details below are general guidelines for spacing and may not be applicable. Please consult AS/NZS 5139 and finalize the spacing in accordance with the specific site conditions.
 - aGate:

The recommended distance between the bottom of aGate and the ground is 1100 mm to 1350 mm, and greater than 150 mm between the top of the aGate and the ceiling. Please finalize the installation height in accordance with the specific site conditions.

There should be at least 600 mm of clearance in front of aGate.
 - aPower:

There should be a minimum clearance of 150 mm from the top of the aPower to the ceiling.

When an aPower is mounted on the wall, the maximum distance between the bottom of the aPower and the ground is 1100 mm.

The minimum distance between multiple aPower units is 110 mm.

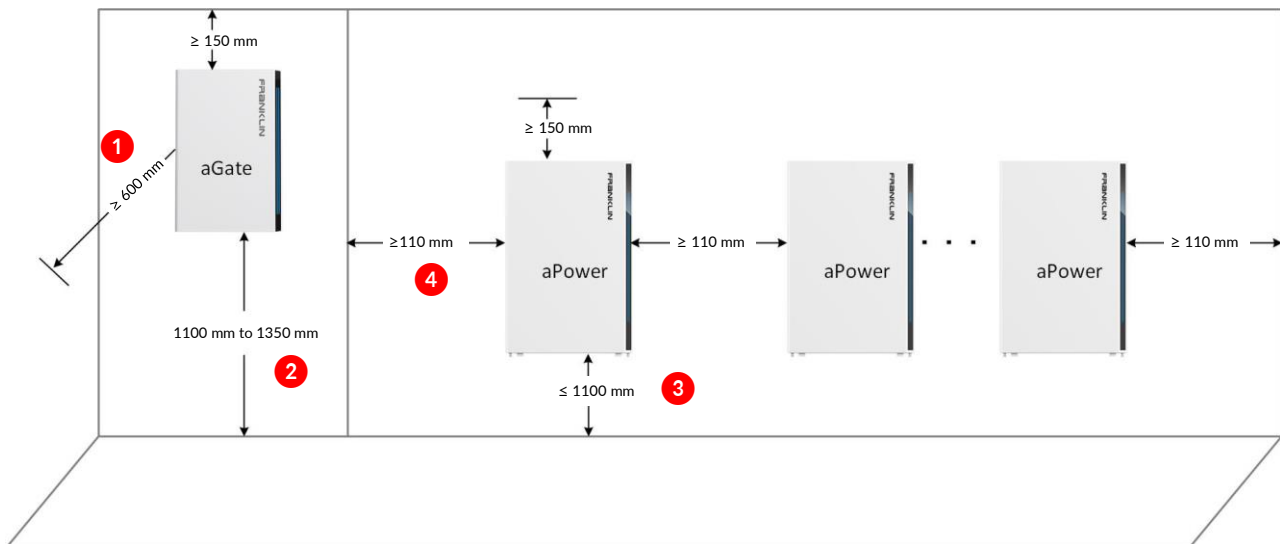

- ① Minimum as per AS3000
- ② Minimum and Maximum should comply with the requirements for switchboards as per AS3000
- ③ Maximum to ensure the On/Off switch on the aPower is Readily Accessible.
- ④ This is a minimum spacing for convection cooling. Please consider access for connection when spacing.

- The FranklinWH system requires an internet connection. All signal transfers between aPower and aGate units, the generator, and the router are realized by a CAN bus, network cables or other signal transmission cables. Long distances will likely adversely affect the quality and speed of communications, negatively impacting equipment operations. The installer or system designer will need to factor in the recommended maximum cable lengths, listed below, when laying out the FranklinWH system installation.

Cable	Maximum cable length
aPower to aGate	30 m
aGate to Generator	30 m
aGate to Router	100 m
aGate to PV CT	3 m

Plan the positions of equipment inputs and outputs

- aPower

The positions of inputs and outputs on an aPower are as shown below. The following scenarios offer variations on the cable inlets and outlets of an aPower to accommodate variations in the existing residential wiring layout.

Scenario 1: The electrical conduits and aPower share the same side of the wall.

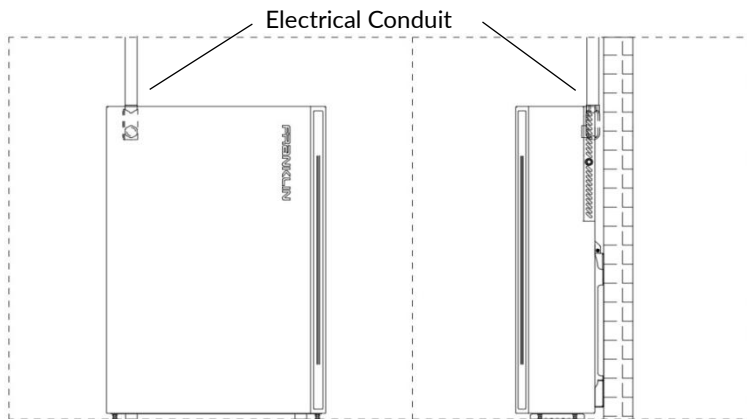

Gasketed conduit adaptors and sealing rings must be used to ensure the tightness of the wiring compartment. The cable inlets on the wiring compartment of an aPower are 35 mm and 28.5 mm in diameter, and the conduit adaptors that work with them have thread size of 32 mm and 25 mm.

Scenario 2: The cables will connect to the aPower from inside or through the electrical conduits through the wall.

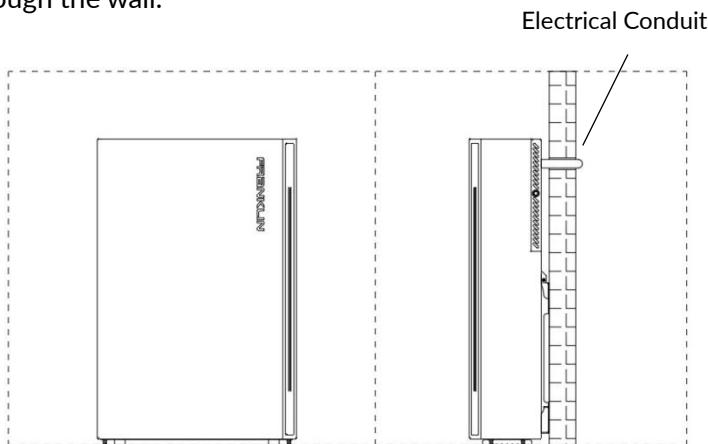

Sealing rings must be used. A good seal must be guaranteed between the electrical conduits and the wiring compartment, which can be achieved by using a conduit Plain to Screwed Adaptor sealing rings, or caulk. The cable inlets on the wiring compartment of aPower are 35 mm and 28.5 mm in diameter.

- aGate

The positions of inputs and outputs on an aGate are as shown below. The following scenarios offer variations on the cable inlets and outlets of an aGate to accommodate variations in the existing residential wiring layout.

Scenario 1: aGate and electrical conduits share the same side of the wall.

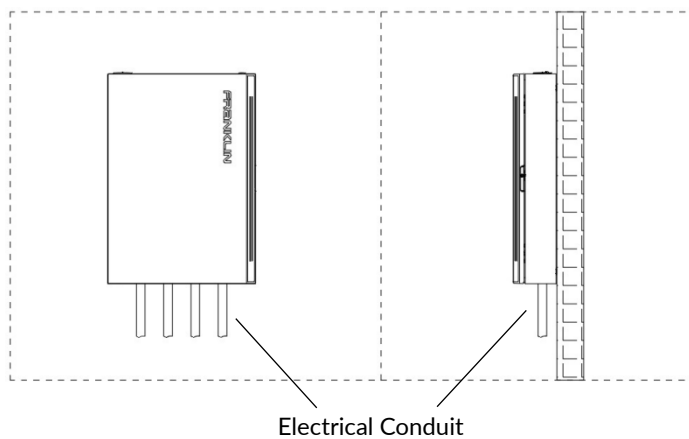

If the aGate is installed outdoors, the electrical conduit is connected to the aGate through the cable inlet on the upper panel. Water-proof sealant or caulk should be used between the reducing fitting, Adaptor, electrical conduit, and the aGate to enhance the watertightness. In other cases, a Plain to Screwed Adaptor is needed to ensure the IP grade of the aGate. The electrical conduit diameter varies by the type of conduits. The knockout holes on the lower panel of the aGate are 20 mm and 40 mm. If the knockout holes do not match the electrical conduits in size, additional reducing fittings will be needed to achieve the required IP grade.

Scenario 2: Cables are run in electrical conduits and enter aGate from inside or through the wall.

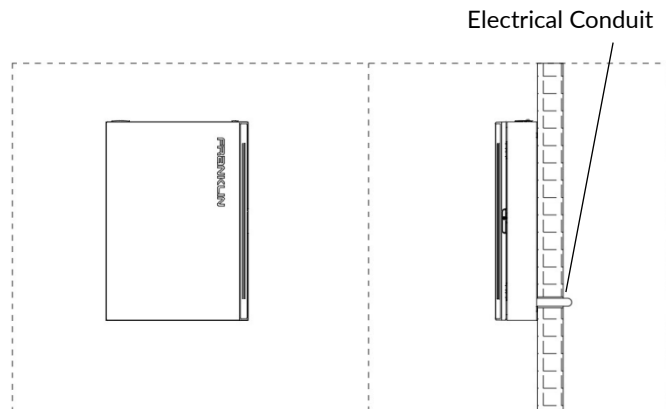

In this case, a conduit adaptor will be needed to ensure the IP rating of the aGate. The electrical conduit diameter varies by the types of conduit. The knockout holes on the back and lower panel of the aGate are 20 mm and 40 mm in diameter. If the knockout holes do not match the conduit diameter, additional reducing fittings will be needed to achieve the required IP grade.

Plan protection for aGate's input connections

The aGate serves as the entrance to the FranklinWH system. Proper lightning protection measures are advised. Over current protection measures are also required. A circuit breaker of up to 80A may be installed at the grid input connection and the generator input connection. Please refer to [Install Breakers as Needed](#) in this Guide for the recommended models of circuit breakers inside aGate.

Plan the types, sizes and routes of cable and electrical conduits

- Please refer to [Electrical Wiring](#) for recommended cable types and wire diameters for electric connections and communication connections.
- As cables run through the electrical conduits, the current-carrying capacity of the cables needs to be reduced. Please refer to the applicable information in AS/NZS 3000 or AS/NZS 3008.1.1.
- The relationship between wire diameters, cable numbers, and inner diameters of conduits should be taken into consideration as cables run through the electrical conduits. Please refer to Appendix C6 of AS/NZS 3000 for the list of maximum numbers of cables of the same size in the electrical conduits and pipelines.
- It is recommended that the electrical conduit be a combination of medium duty electrical PVC and a corrugated conduit. This is preferred for home cable installation and can provide effective mechanical protection as well as maintaining IP Ratings

Plan the Fire Control and Extinguishing System

The selection and installation of fire control and extinguishing systems on power storage systems must comply with the requirements of AS/NZS 5139 and local fire authorities.

Tools

- Personal Protection Equipment (PPE) (goggles, gloves, protective shoes, anti-dust respirator, etc.) to protect the personal safety.
- Drill
 - Use 4 mm Brad Point bits or 4 mm Auger bits to drill pilot holes in wooden walls.
 - Use 13 mm, 20 mm, 25 mm, 40 mm, 50 mm sized wood bits to create holes in wooden walls.
 - Use 13 mm, 20 mm, 25 mm, 40 mm, 50 mm sized hole saw bits to create holes in metal walls.
- Hammer drill
 - Use 13 mm, 10 mm Masonry bits to create pilot holes on concrete or brick walls.
 - Use 13 mm, 20 mm, 25 mm, 40 mm, 50 mm Diamond core bits to create holes in concrete or brick walls.
- Electric screwdriver and cross screw bits to tighten the fastening screws
- Torque wrench and bent-handle ratchet wrench
 - Use 8 mm, 9 mm, 10 mm, and 11 mm hex sockets, to tighten and check the torque of outer hexagonal bolts.
 - Use 5 mm and 6 mm inner hexagon screwdriver bits to fasten cables at circuit breakers and pressure connectors and to check the torque.
 - Use 5 mm, 6 mm straight screwdriver bits to fasten cables at circuit breakers and connectors and to check the torque.
 - Use PH2, PH3 cross screwdriver bits to fasten cables at circuit breakers and to check the torque.
 - Use 150 mm Phillips head extension.
- Flat head screwdriver (3 x 100 mm, 6 x 100 mm) to fasten signal terminals and take wooden boxes apart.
- Phillips head screwdriver (#2 x 100 mm, #3 x 100 mm) to tighten fasteners.
- Claw hammer to break knockout holes and to release locks on wooden box.
- Utility knife to cut open cartons.
- Needle nose, vise grip, wire stripper, wire cutter, utility wire shear, and other cable preparation tools.
- Wire crimper, network cable testers, wire tracker, and other network cable preparation tools.

- 14 mm open-end wrench to operate aPower leveling screws and to adjust the height of aPower.
- Induction electroprobe to detect the cables in walls to avoid short circuits when drilling.
- Multimeter to measure voltage, current and other electric parameters.
- Loop resistance tester to measure the wiring resistance and to detect poor connection of cables.
- Task light to illuminate the area when power supply is off.
- Spirit level to check whether the equipment is level.
- Steel measuring tape to measure lengths.
- Markers to make drilling marks.
- Camera to record the installation process.
- Deep cut band saw to cut thin-wall steel conduit or PVC conduit.
- The aPower is heavy. Several well-trained workers are required to maneuver the unit. Use of a lift is recommended to avoid potential injury.
- Knockout tool kit to drill holes for conduits on the distribution box case.
- Wooden block, size: 44.4 mm x 680 mm x 60 mm. *(If front add if not using supplied template a Wooden Block)*
- Adjustable wrench, size: 0-50 mm.

**NOTE:**

Battery-powered or hand tools are preferred because there may not be any power source at the site.

Torque Requirements

Screws and torques		
Screw Type	Cross head screwdriver	Tightening torque
M4	PH2	1.4 Nm
M5	PH2	3.0 Nm
M6	PH3	6.0 Nm

Materials

• aPower and Accessories Provided

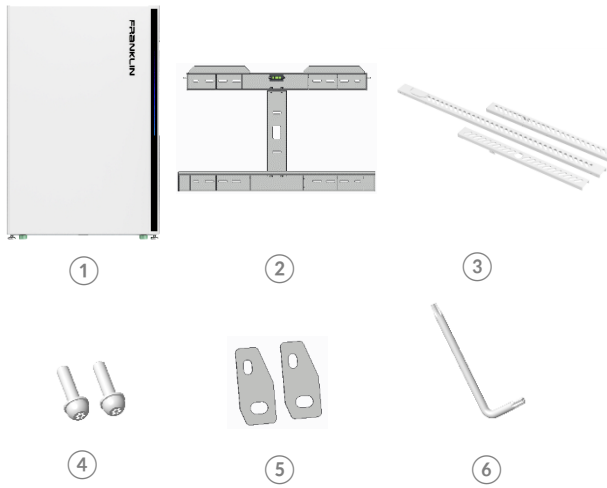

No.	Item	Quantity
1	aPower	1 PC
2	Mounting bracket	1 PCS
3	Grilles	1 Set
4	M5x20 screws	2 PCS
5	Retainer plates	2 PCS
6	Wrench	1 PCS

• aGate and Accessories Provided

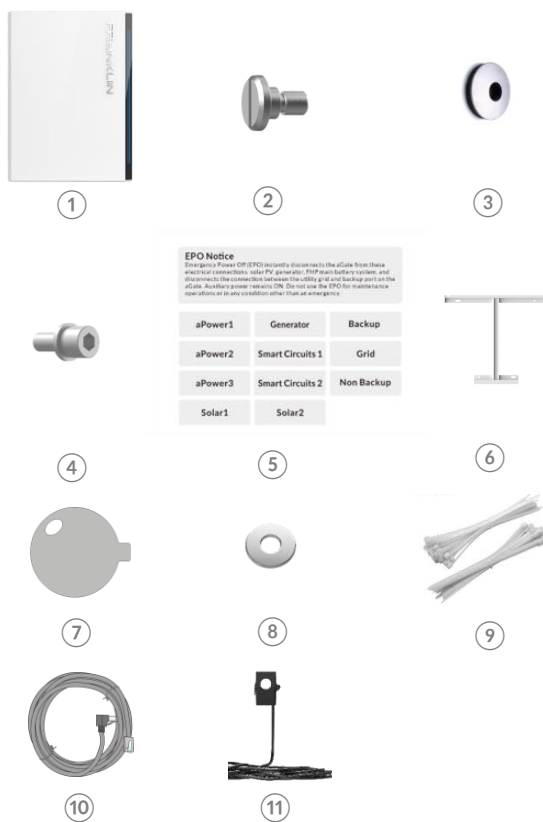

No.	Item	Quantity
1	aGate	1 PC
2	Slotted screws	3 PCS
3	Water-tight washers	2 PCS
4	Hexagon socket screws	2 PCS
5	Switch tag	1 Set
6	Mounting bracket	1 PC
7	Grid relay reset handle toggle	1 PC
8	Large flat washers	4 PCS
9	Cable ties	10 PCS
10	5 m communication cable	1 PC
11	CT	1 PC

The list of accessories is for smart demonstration purposes only. Depending on product version, details may appear slightly different.

• Materials Provided by Installers



No.	Item
1	Electrical conduit, conduit adaptors and fittings
2	Copper cables
3	Antioxidant conductive paste (if using aluminum conductors)
4	Screws and M6 spacers for wall installation
5	Circuit breakers. For details, refer to Install Breakers as Needed for circuit breaker models
6	External PV and grid CTs (three-phase solution)
7	Conduit fitting washers
8	Sealant (for use on outdoor conduits)
9	A suitable barrier material as per AS/NZS 5139 to level walls
10	Network cable and registered jacks

Installation

Moving

DANGER:



Special care must be taken to protect personal safety. Reinforced toe shoes must be used to protect the installers in case equipment tilts and falls.



- Compare and confirm the equipment delivered against the order information.

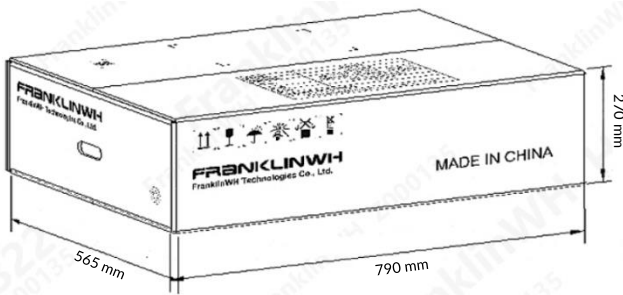

aGate

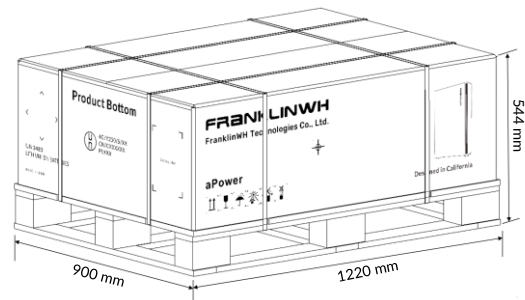

aPower

aPower Installation

Unboxing and Transporting the aPower

- 1) Visual inspection for damages, collision, or scratches, etc.

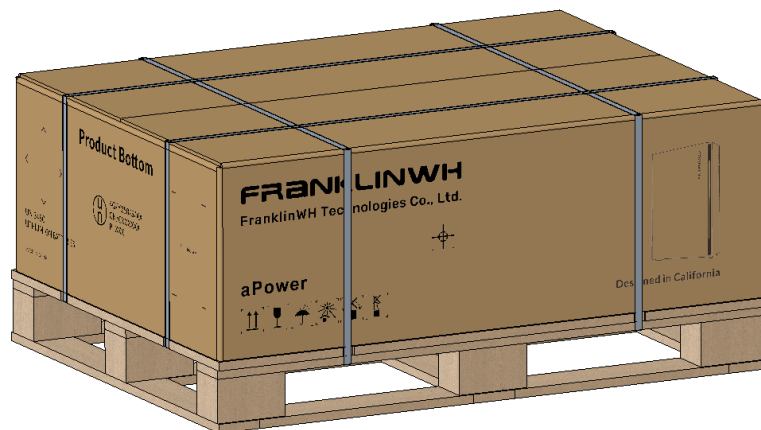

- 2) Cut the sealing tape and lift up the cardboard cover. Remove the protective carton and top foam.

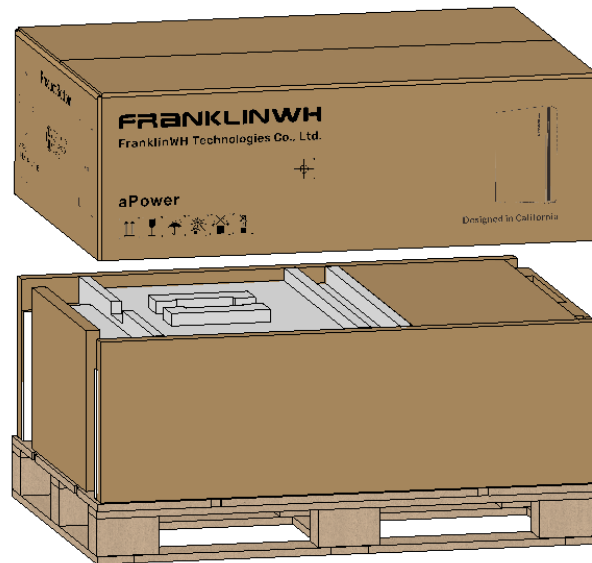

- 3) Stand up the aPower (logo faces up). Several installers should work together to protect the equipment from falling.
- 4) Move the aPower to the installation site. A lift is recommended to transport the aPower to the installation site.

NOTE:

Please wrap the aPower in a protective blanket and keep the aPower well fastened during the transportation and handling process to avoid scratches or damage.

It is advisable to unscrew the feet of the agate prior to standing up. This will allow for the trolley with protective measures to be inserted and removed from under the aPower. It is easier to wind the feet in to lower the unit to level than wind the feet out to raise.

Mount the Bracket

- Before mounting

- A mounting bracket is required for both floor and wall mounting. The mounting bracket should be fastened to the wall at a minimum of 4 points, one on each arm.

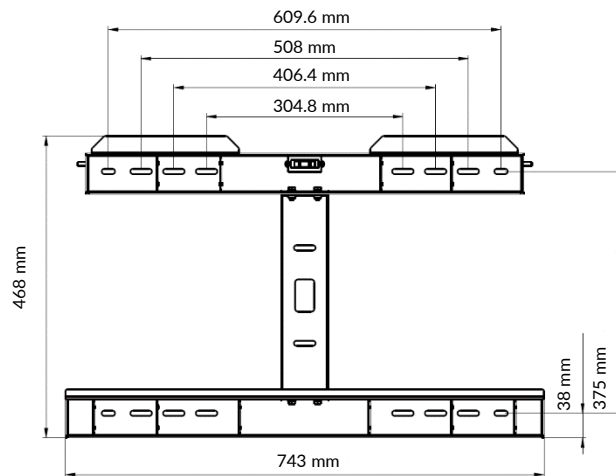

- Examine the smoothness of wall. If the wall is not smooth and straight to the floor, a suitable barrier material should be installed to level the surface and ensure all parts of the mounting bracket are well supported by the wall.

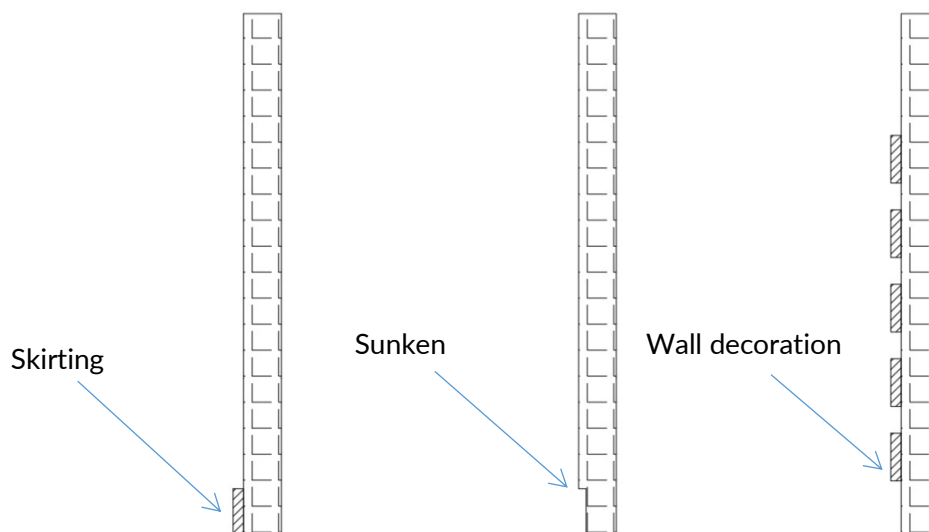

➤ Special Wall/Baseboard Installation

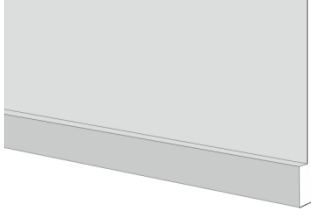
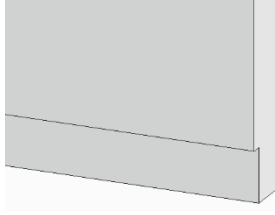
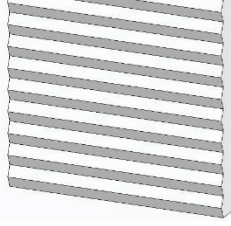
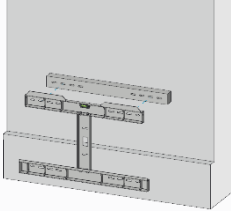
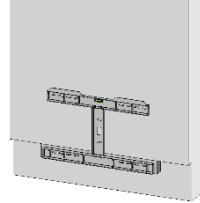
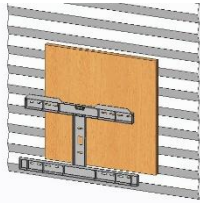
<p>Case 1: Protruding Baseboard Height > 152 mm or the thickness of the bulge > 25 mm (Floor mount)</p>	<p>Case 2: Concave Baseboard Height > 152 mm (Floor mount)</p>	<p>Case 3: Uneven Wall</p>
		
<p>Solution Use wooden or steel spacers on the upper part of the bracket (to keep it flush with the baseboard).</p>	<p>Solution Use wooden or steel spacers on the indented part of the baseboard (to make it flush with the wall).</p>	<p>Solution Use suitable barrier material to level the wall. The recommended thickness is 13 mm.</p>
		

***NOTE:** These materials are prepared by the installer.

- Mounting the bracket on a wall

- Choose the fasteners and installation holes depending on the type of wall. Ensure the installation location can bear the weight of aPower and bracket.

**NOTE: When the bracket is attached in the outdoor, windy area, at least 12 M6 screws (3 at each corner) should be used to mount the bracket.*

- There are two ways to determine bracket mounting points.

Method 1: Use the cardboard positioning template to mark the mounting points.

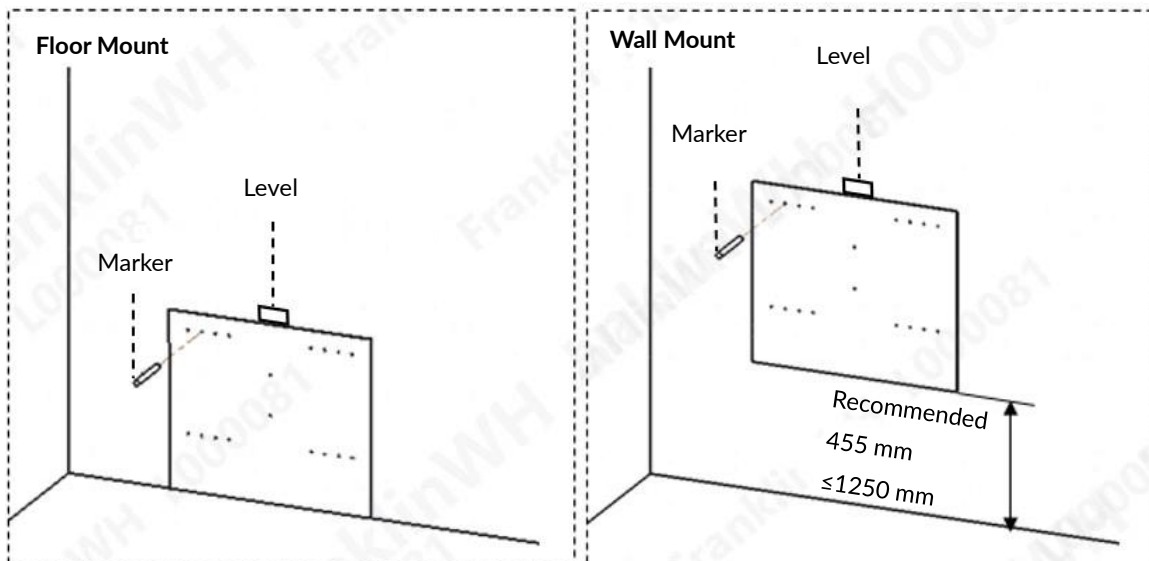

- ① Place it against the wall in the planned installation position according to the orientation of the cardboard text (the bottom of the cardboard is on the ground when it is installed on the ground).
- ② Use a level to adjust the installation angle.
- ③ Make marks through the mounting holes where the fasteners will be used.

Method 2: Use the bracket to mark the mounting points.

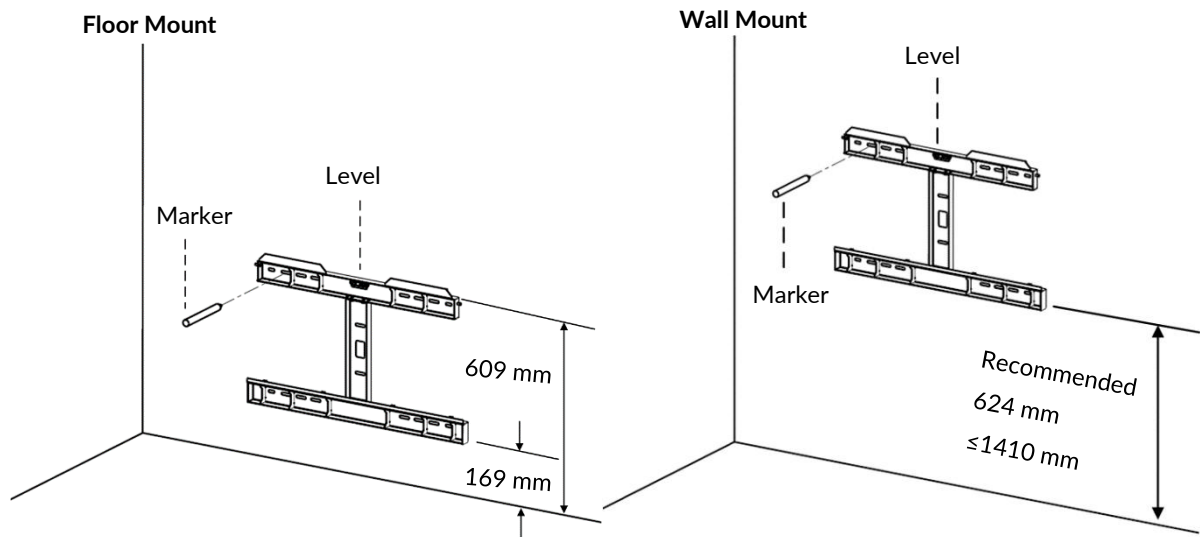

Floor mount

- ① Place the mounting bracket at the planned installation position and support the mounting bracket using a 169 mm thick wood block.
- ② Use the built-in level to adjust the installation angle.
- ③ Make marks through the mounting holes where the fasteners will be used.

Wall mount

- ① Two installers will be needed to complete the installation. One installer supports the mounting bracket, keeping the bracket at the desired position on the wall. Adjust the bracket angle using the level.
- ② The other installer marks the mounting holes where the fasteners will be used.

➤ Mount on wooden beams

The following are the basic steps for installing the bracket on wooden beams:

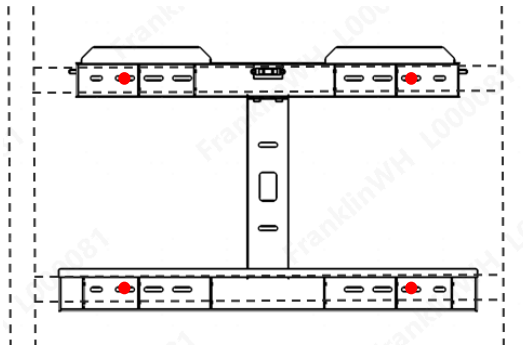

At least 4 M6 stainless steel wood screws with large flat washers (1 at each corner), at least 64 mm of each screw inserted into the wooden beam.

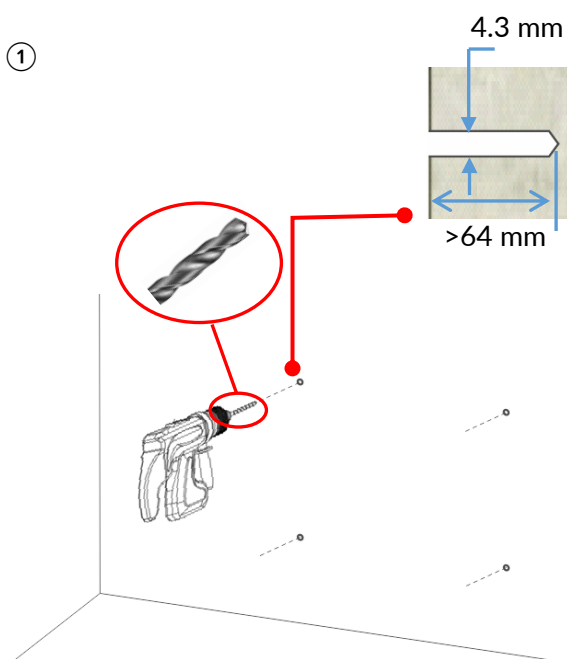

① Select an appropriate drill bit to drill holes at the marked points. The diameter of the holes should be 4.3 mm and the depth of the holes should be at least 64 mm. Remove debris from the hole.

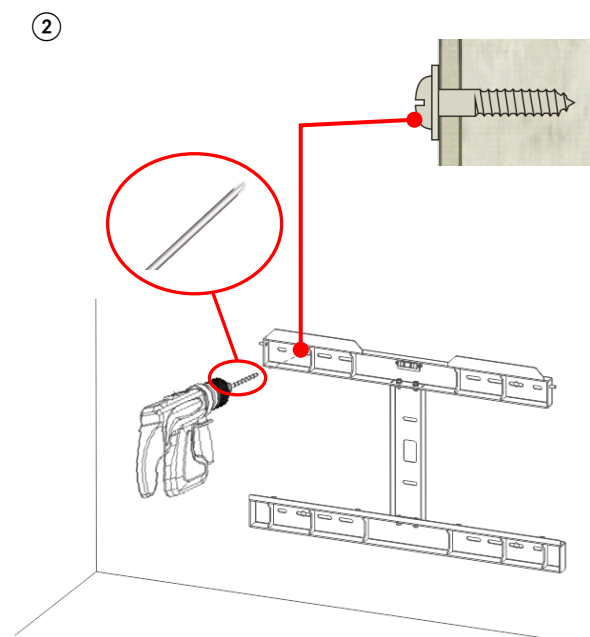

② Use a wood screw with a large flat washer to ensure secure installation.

➤ Mount on steel beams

The following are the basic steps for installing the bracket on steel beams:

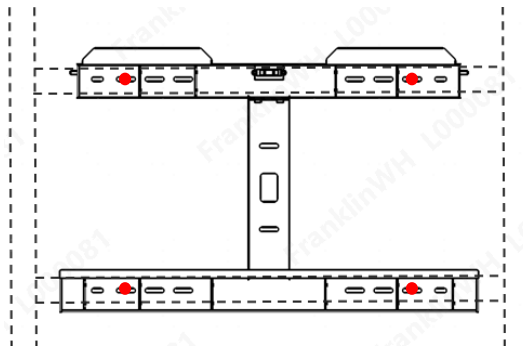

Use at least 4 M6 stainless steel hexagon screws (1 at each corner) with spring washers, large flat washers and nuts to secure the bracket to the steel beam.

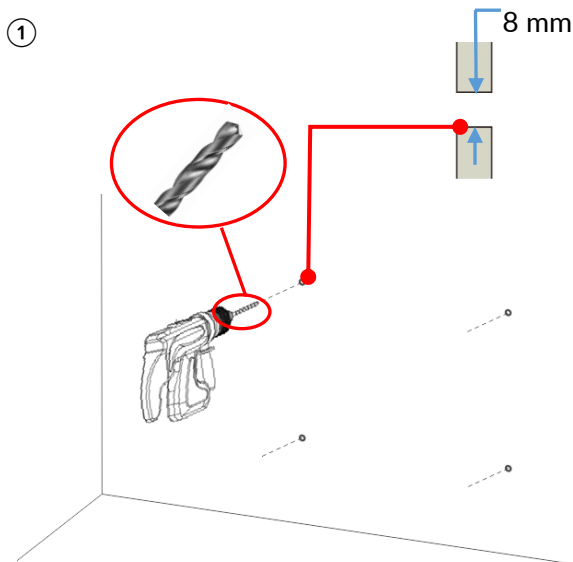

① Select a suitable drill bit to drill holes at the marked points. The diameter of the holes should be 8 mm and the depth of the holes should be through the steel beam. Remove debris from the hole.

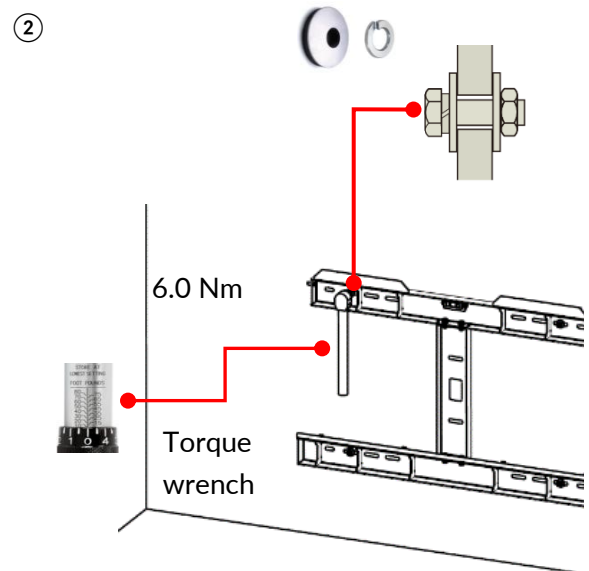

② Use M6 stainless steel hexagon screws with spring washer and large flat washer and hexagon nuts to fix the support to the steel beam holes. Tighten to 6.0 Nm.

- Mount on concrete or brick walls

The following are the steps for installing the bracket on concrete or brick:

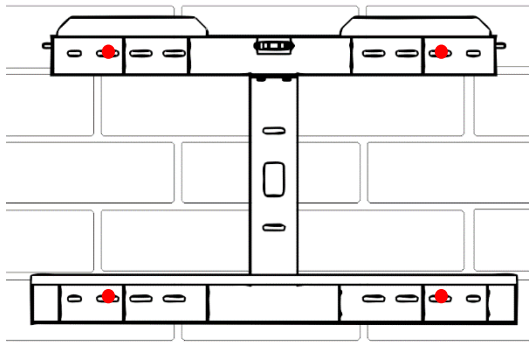

Use at least 4 M6 expansion bolts of a suitable material for the location (1 at each corner) with spring washers and large flat washers and at least 40 mm length embedded in the wall. Place screws at least 40 mm away from brick edge.

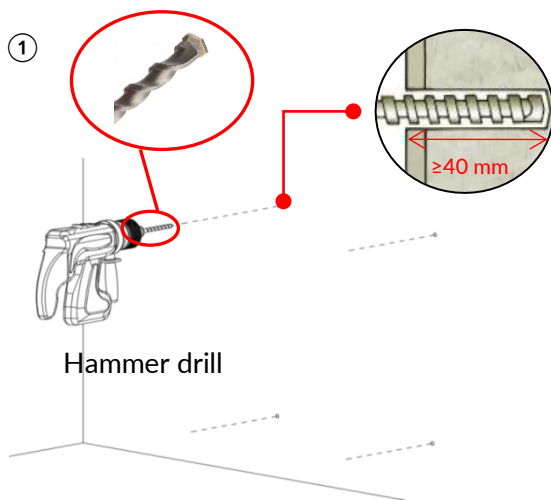

① Using an appropriate drill bit for the type of wall, drill holes the same diameter as the anchor diameter, and at least 40 mm deeper than the expected embedment. Ensure that all fasteners are at least 40 mm away from the edges of masonry blocks or bricks. Remove debris from the holes.

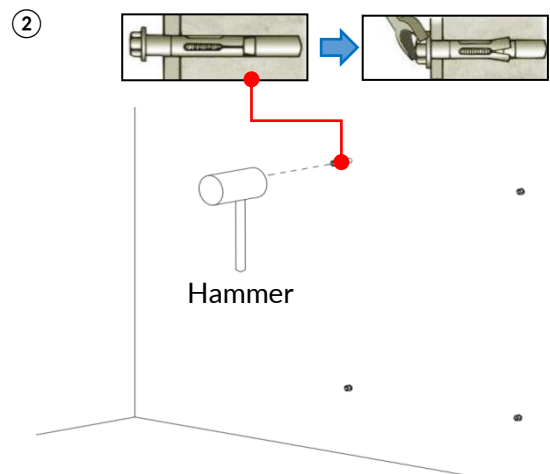

② Set the nut flush with the top of the sleeve anchor. Use a hammer to drive the sleeve anchor into the hole in the base material until the washer and nut are tight against the fixture. Tighten the anchor by turning the nut three to four turns with an appropriate tool.

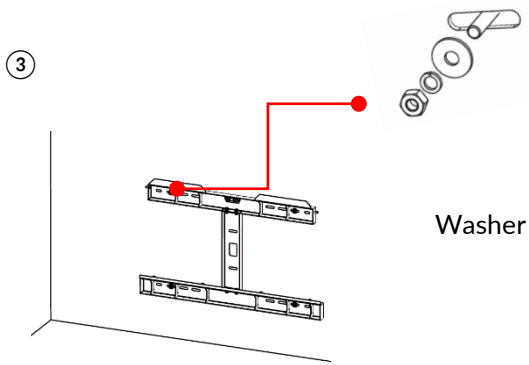

③ Use an 11 mm wrench to turn the nut in the opposite direction, and remove the nut, spring washer, and flat washer from the sleeve anchor. Set the mounting bracket at the sleeve anchor points.

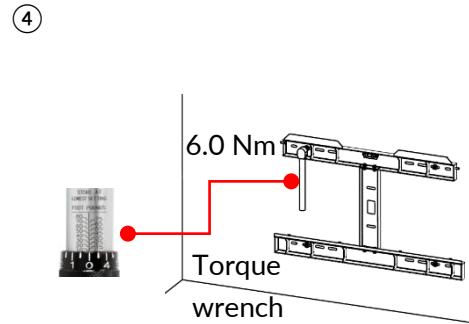

④ Use an 11 mm wrench to attach the mounting bracket by turning the nut until the torque is 6.0 Nm.

Drill Cable Inlet Holes on The Wall (if needed)

As shown below, the positions of holes in the wall depend on the positions of the mounting bracket. If there is any metal or wooden supporting structure in the drilling area, necessary adjustments are required to avoid it.

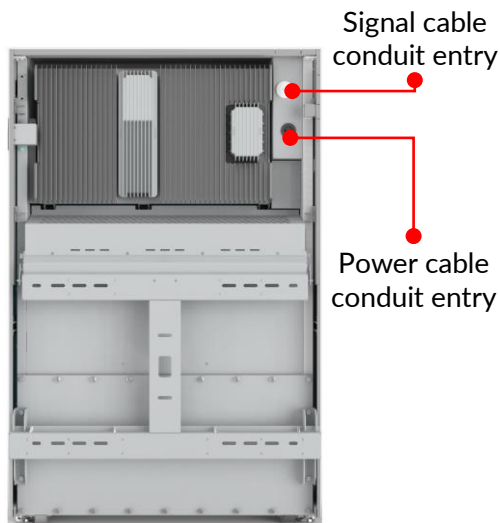

aPower rear view

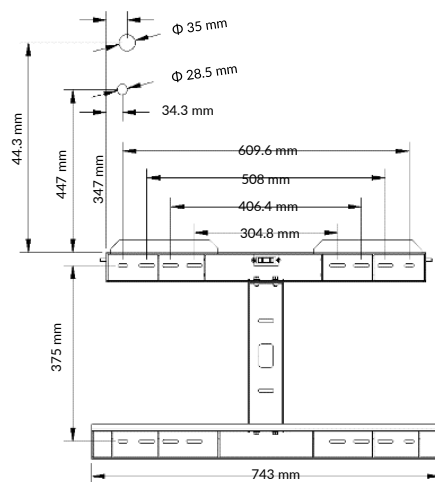

Positions of mounting bracket and conduits entry holes on the wall.

***NOTE:** The size of holes depends on the size of the electrical conduits.

DANGER:

- Avoid drilling holes in water pipes and cables in the wall.
- PPE must be used in the operation.

WARNING:

If any drilling is conducted over the aPower when installed, cover all ventilation grills to protect from gravel dust or other foreign objects

**Wooden wall**

Electric drill and 25 mm, 32 mm wood bits are recommended to create holes for running cable through wooden walls.

It is important that the drill bit be kept perpendicular to the wall when drilling.

**Concrete or brick wall**

Hammer drill and 25 mm, 32 mm diamond tipped core bits are recommended to create holes for running cables through concrete or brick walls. Wet the wall and HEPA vacuum the dust, to protect the drill bits from overheating.

It is important that the drill bit should be kept perpendicular to the wall when drilling.

**Metal wall or metallic studs**

Electric drill and 25 mm, 32 mm hole saw are recommended to create holes for running cables through metal plate and metallic studs.

It is important that the drill bit should be kept perpendicular to the installation surface when drilling.

Mount the aPower in the Bracket



DANGER:

Special care must be taken to protect personal safety. Reinforced toe shoes must be used to protect the installers from tilting and falling equipment.



WARNING:

Please use proper protective measures on the lift, such as foam or protective cloth, and take effective protection measures to avoid scratching or damaging the aPower during the installation process.



NOTE:

For easy installation, before wall-mounting the aPower, refer to [Electrical Conduits](#) to remove the aPower wiring compartment cover, 2 external charging cables and cable conduit hole-plug 25 mm, then pre-install the conduit adaptor (Protect the wiring compartment to prevent damage to the interface board).

- ① A lift is needed to raise the aPower. Raise the aPower so that top mounting cleats on the back of aPower is higher than the top of the mounting bracket.



- ② Adjust the lift until the mounting bracket is completely aligned to the clips on the back of aPower and within locking position of the joint, and the top and bottom mounting cleats are firmly locked by the mounting bracket. During this process, the installer needs to push on the front of the aPower to ensure that the back side locks securely into the mounting bracket.

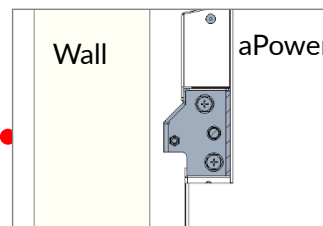

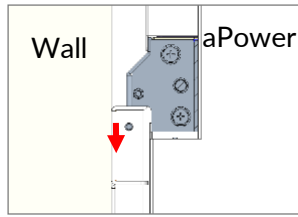

- ③ After the aPower is firmly set on the mounting bracket, attach the two retainer plates to both sides of the upper bracket. The larger hole fits over the post on the side of the top bar of the mounting bracket. The smaller hole on the retainer plates should be attached to the aPower at the nut with the M5*20 screws. Tighten to a torque of 3 Nm.

Retainer plate

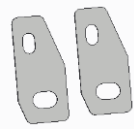

Fasten using M5*20 screws

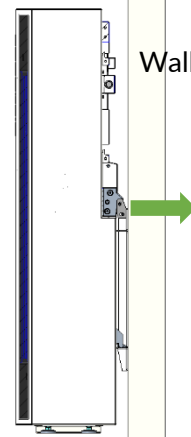
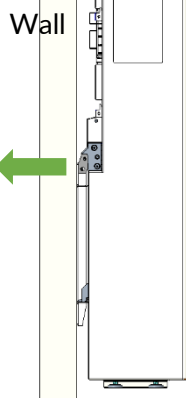
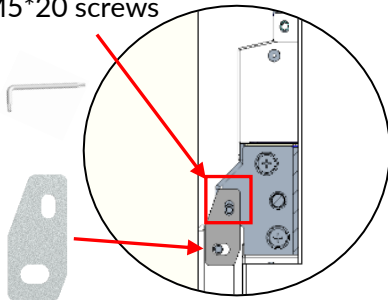

Fasten using M5*20 screws

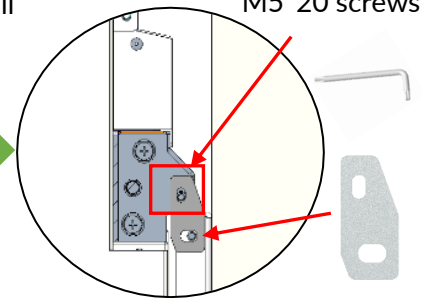

Adjust the Floor Mounted aPower Level

If the aPower is to be installed on an uneven floor, the leveling screws on the bottom of aPower cabinet can be adjusted until the screw directly contacts the floor, the maximum adjustable height of the leveling screws is 25mm.

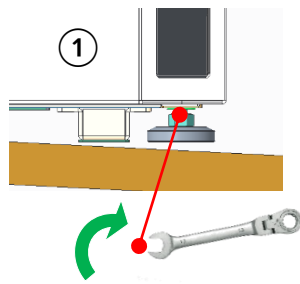
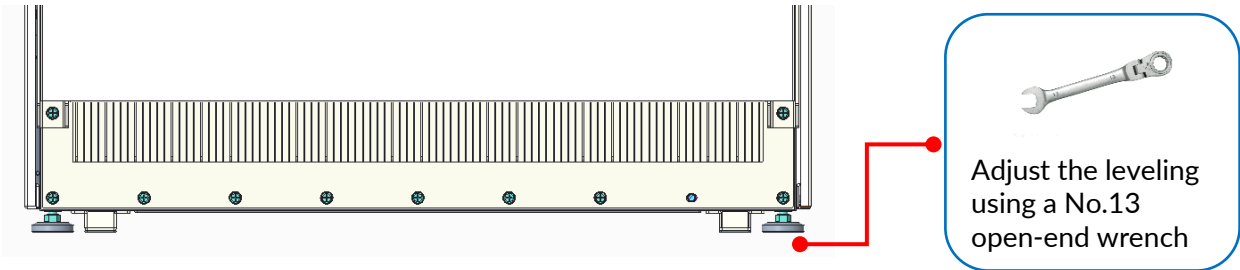

Turn clockwise to loosen the nut.

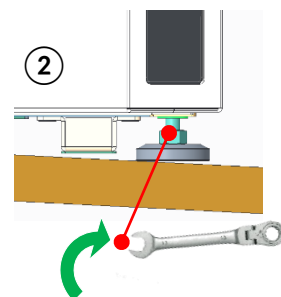

Turn the bolt head clockwise until the screw head hits the ground. The leveling process of aPower is finished.

NOTE:



If the feet are unscrewed when the aPower is unpacked, it is easier to remove from trolley and level the unit

aGate Installation

NOTE:

- The drill template guide board will be used for drilling mounting holes. Keep it in good condition prior to use.
 -  The film wrapped around the aGate will be used to protect the internal components of the aGate when drilling mounting holes. Do not tear the film until the drilling is complete.
 - During the installation process, keep the aGate well protected from hard objects that may scratch the aGate surface and body.
-

Unbox the aGate

- Visual inspection for damages, collision, or scratches, etc.
- Unboxing: Adjust the utility knife until the blade is less than 7 mm long (it may damage aGate if too long). Cut open the adhesive tape on the upper surface of the aGate carton.

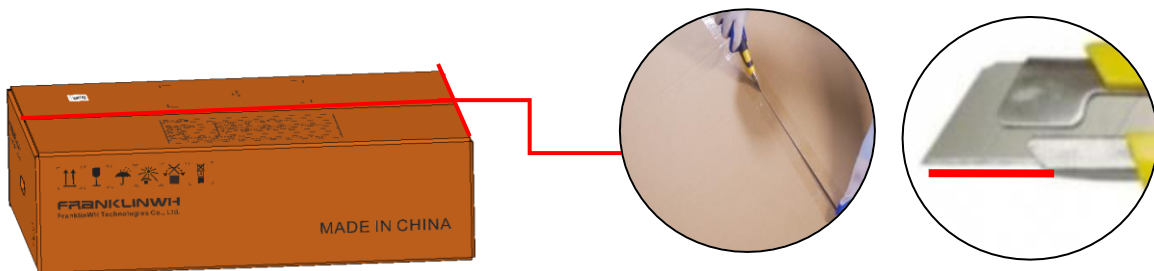

- Open the aGate carton, take out the template guide board and accessories, and then take the aGate out of the box.
- Remove the packing foam from both sides of the aGate and remove the PE bag.

Remove the Door and Inner Panel from the aGate

Grasp the small notch on the right side of the aGate. Lift it slowly until the door of aGate is completely open.

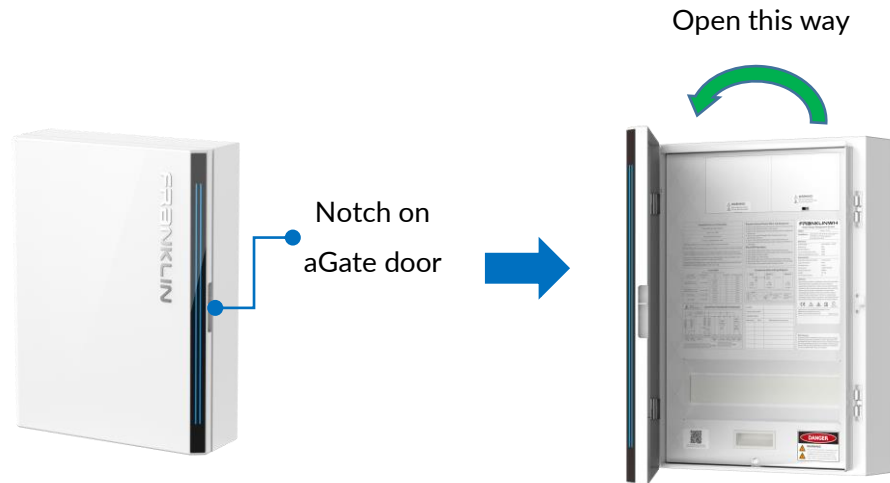

WARNING:



The door may only be opened to a maximum of 100°, beyond which the door may be cracked.

-
- Remove the door: Gently lift the door panel upward, remove the aGate door after the hinges are separated, and properly store it.



- Remove the inner panel: Use a #3 Phillips head screwdriver or an electric screwdriver with a Phillips head screw bit. Turn the screw fastening the inner panel counterclockwise to remove the screws. Remove the aGate inner panel and properly store it.

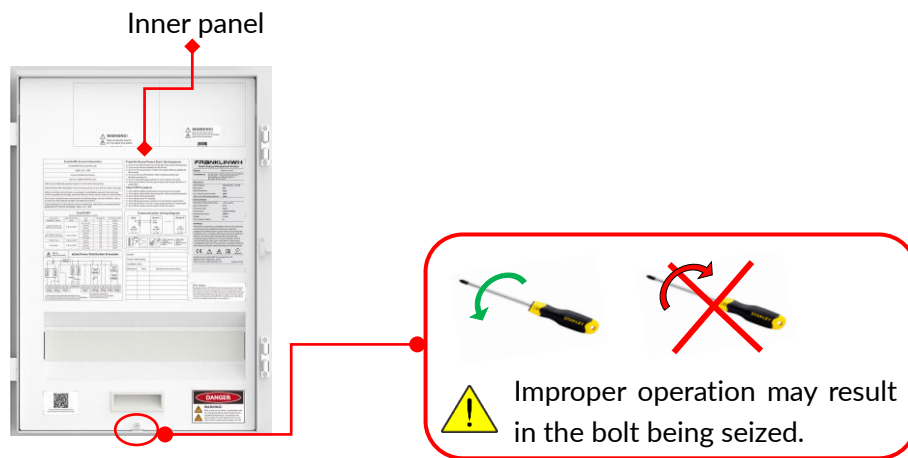

Prepare aGate Cable Inlets

The aGate has eight 20 mm and 40 mm diameter knockouts. Remove the necessary knockouts or plugs in the aGate.

- How to remove the Knockouts?

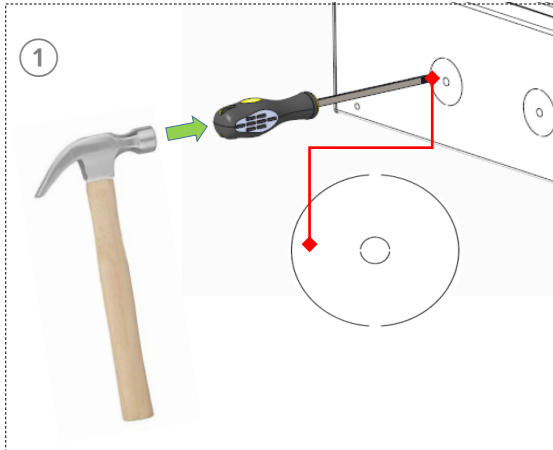

① Place a flathead screwdriver against the edge of the knockout hole, and then knock it with a claw hammer.

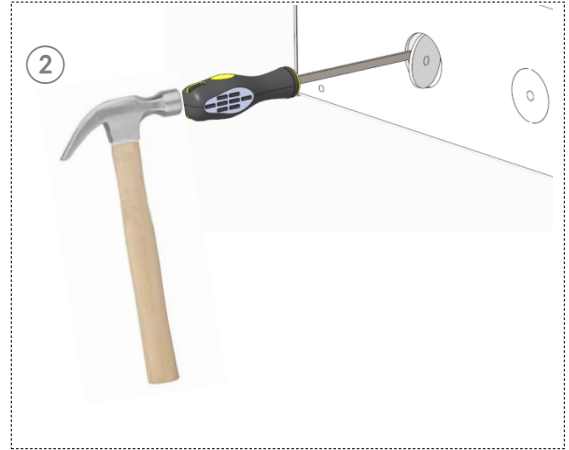

② Keep knocking until the knockout angled out.

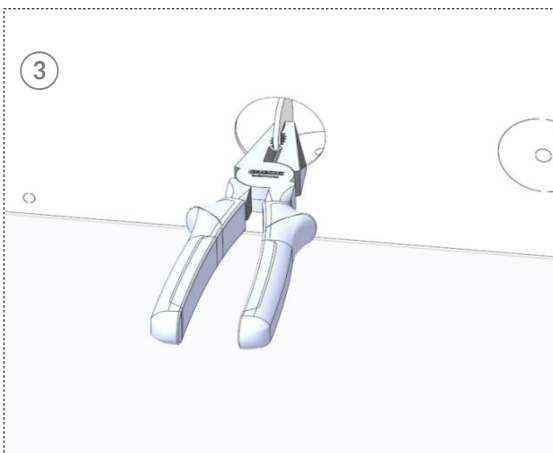

③ Use needle nose pliers, twist the knockout back and forth until the attachment points snap.

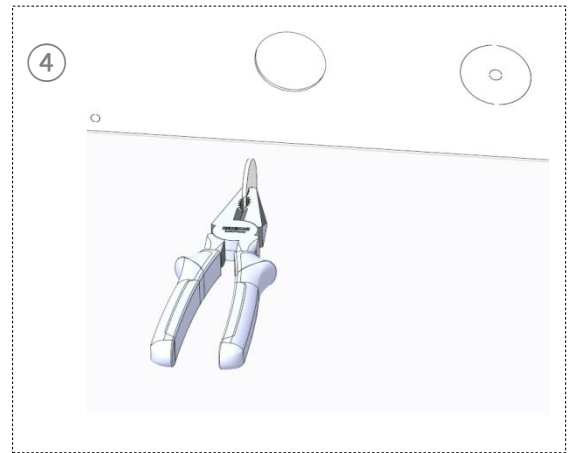

④ Remove the knockout. If burrs remain, remove them with a deburring tool.

Enlarging or Drilling New Holes (if necessary)

If the conduit diameter is larger than the aGate knockout hole, or if any new hole needs to be drilled, appropriate tools should be used to expand the hole or to drill new holes.



***NOTE:** To avoid damage to equipment, completely shield all aGate interior electrical boards and components before you drill or punch holes, to avoid debris falling into the aGate.

The aGate is shipped in a protective film. When enlarging or drilling new holes on the aGate, unwrap the outer film and use it to protect the components inside the aGate, as shown below. Keep the film in place while drilling and punching holes. Remove all dust and debris before unwrapping the aGate for mounting.

White film wrapped on delivery



Site protection diagram



Install Optional Module(s)

The Smart Circuits Module and Generator Module are optional parts. If the user did not purchase them, please skip this step. Below images shows all the breaker

Install the Smart Circuits Module

The Smart Circuits Module can remotely control the on/off status of two (2) Smart Circuits, which may be set and controlled separately.

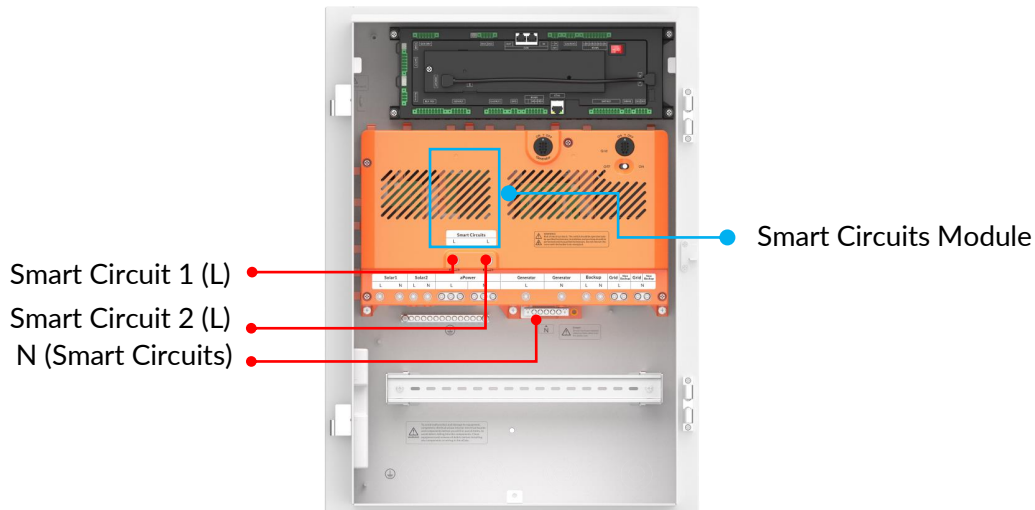

DANGER:



- While the Smart Circuits when viewed and controlled remotely on the FranklinWH App may indicate the circuit is **OFF**, this status does not mean the circuit has been physically disconnected. It is important to test the circuit status during the installation process.
 - Do not touch the terminals of the Smart Circuits Module directly or via non-insulated tools, before disconnecting the circuit breakers and testing to confirm de-energized.
-

Installation Steps

- 1) Make sure all breakers in the aGate and all switches connected to the aGate are disconnected. Use a multimeter to check the voltages at both input and output terminals of aGate are 0.
- 2) Put the Smart Circuits Module in the position as shown in the figure below and check that all installation holes 1 to 2 have been properly aligned.

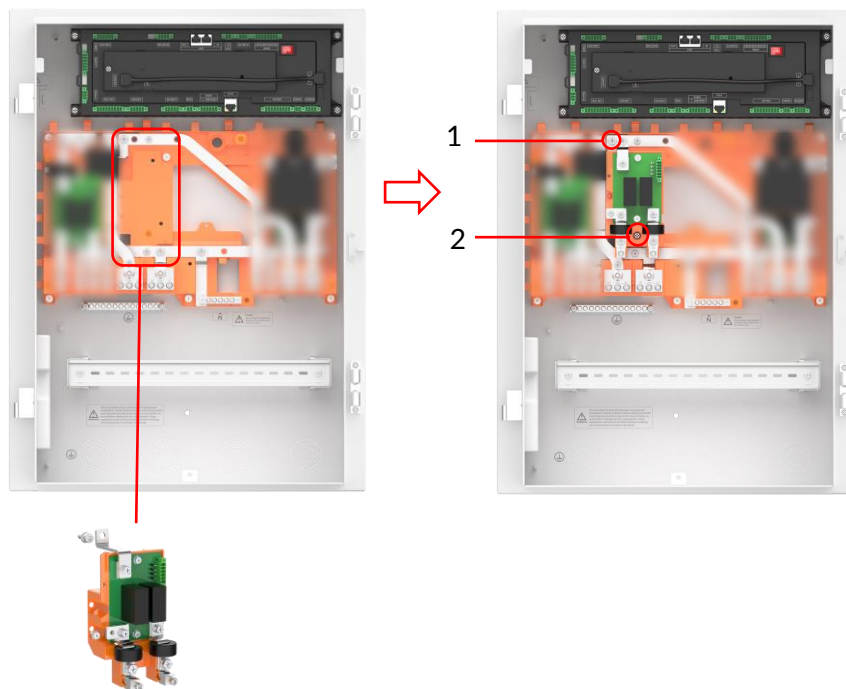

- 3) Tighten (clockwise) the 1 x M6 washer screws at positions 1 to 6.0 Nm using a #3x100 mm Allen key. Tighten (clockwise) the 1 x M5 washer screws at positions 2 to 3 Nm, using a torque screwdriver.

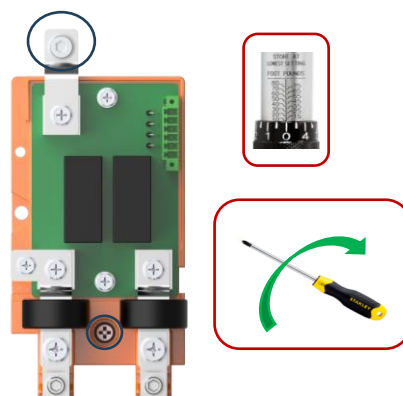

The recommend installation parameter please refer the following table.

Item	Applicable Cable	Wiring Torque	Stripping Length
Smart Circuits	2.5-10 mm ²	3.9-4.5 Nm	12 mm

4) Wiring the 3 types of cables respectively.

- ① The SMT CT cable is being used for CT current reading. Plug the CT cables into the SMT CT connection port to complete the connection. Use flat head screw to tighten the screws on the plug.
- ② The SMT RLY is being used for power supply of Smart Circuit. Plug the relay drives cables into the SMT RLY connection port. Plug the other end to the Smart Circuit's J4 Port. Use flat head screw to tighten the screws on the plug.
- ③ The Voltage Sampling Cable is being used for sampling voltage. Remove the heat shrink tube of the voltage sampling cable on the aGate (See step b) and route to the voltage sampling port. Use a Phillip-head screwdriver to tighten the M4 screw.

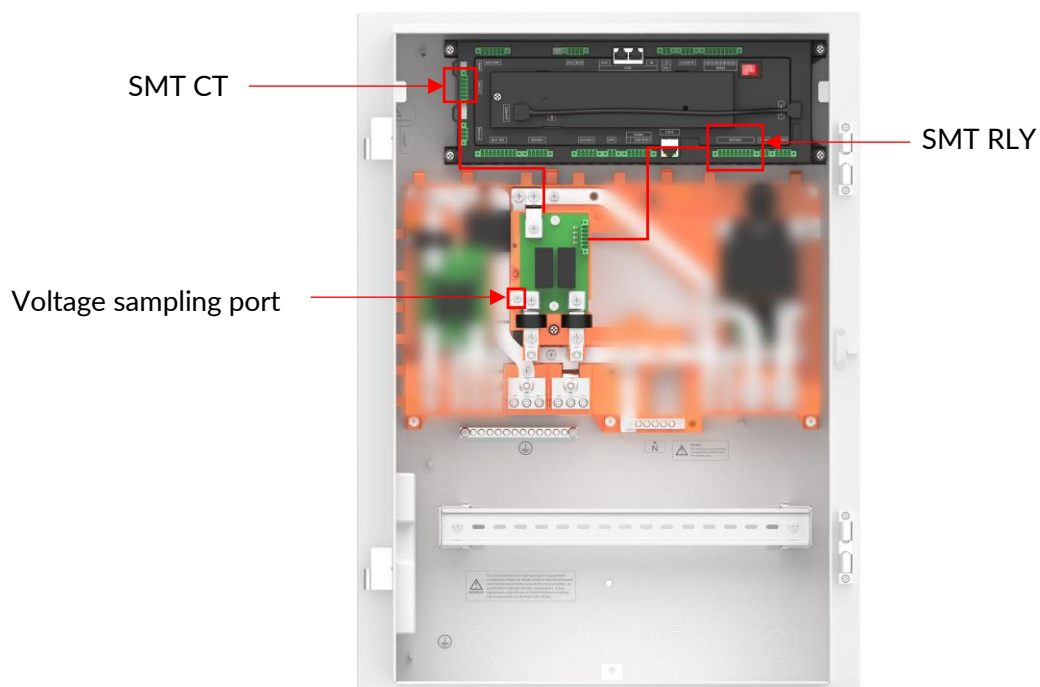

Install Generator Module

The FranklinWH system can connect to a household backup power generator (generator) via the optional aGate Generator Module.

- 1) Make sure all breakers in the aGate and all switches connected to the aGate are disconnected. Use a multimeter to check that the AC voltages at both input and output terminals of the aGate (as shown below) are zero (0).
- 2) Use a #3 x 100 mm Phillips head screwdriver to loosen the four M5 captive screws on the protective cover, remove the protective cover and keep it in good condition.

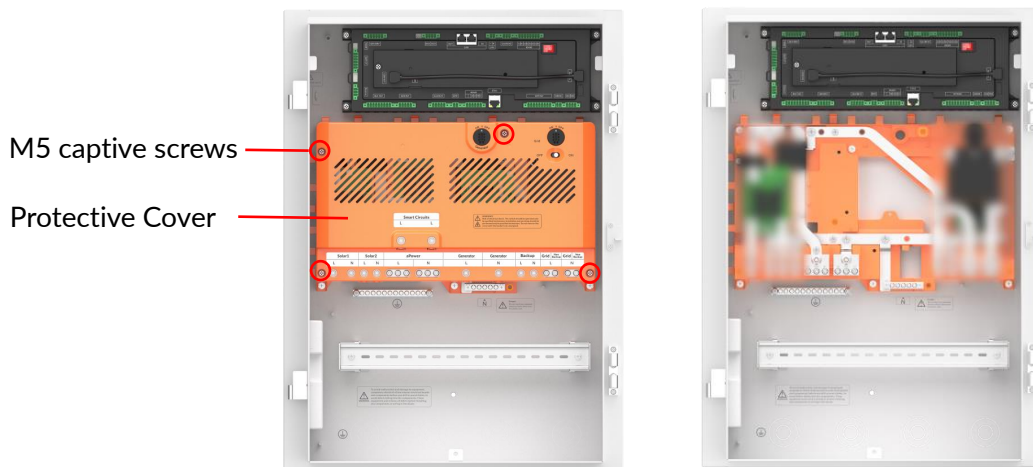

- 3) Follow the steps below to install the Generator Module onto the aGate.

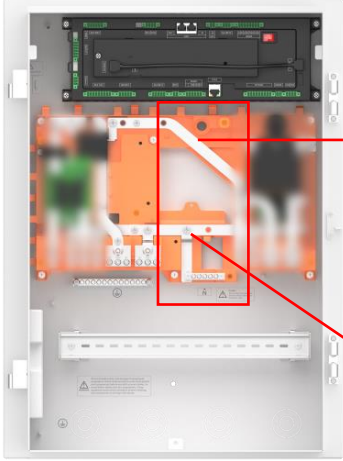

①



Place the Generator Module in the proper position and check that all installation holes have been properly aligned. Tighten the two M6 combination screws at the positions marked to the recommended torque using a Phillips head screwdriver.



②

Remove the heat shrink tube of the voltage sampling wire.

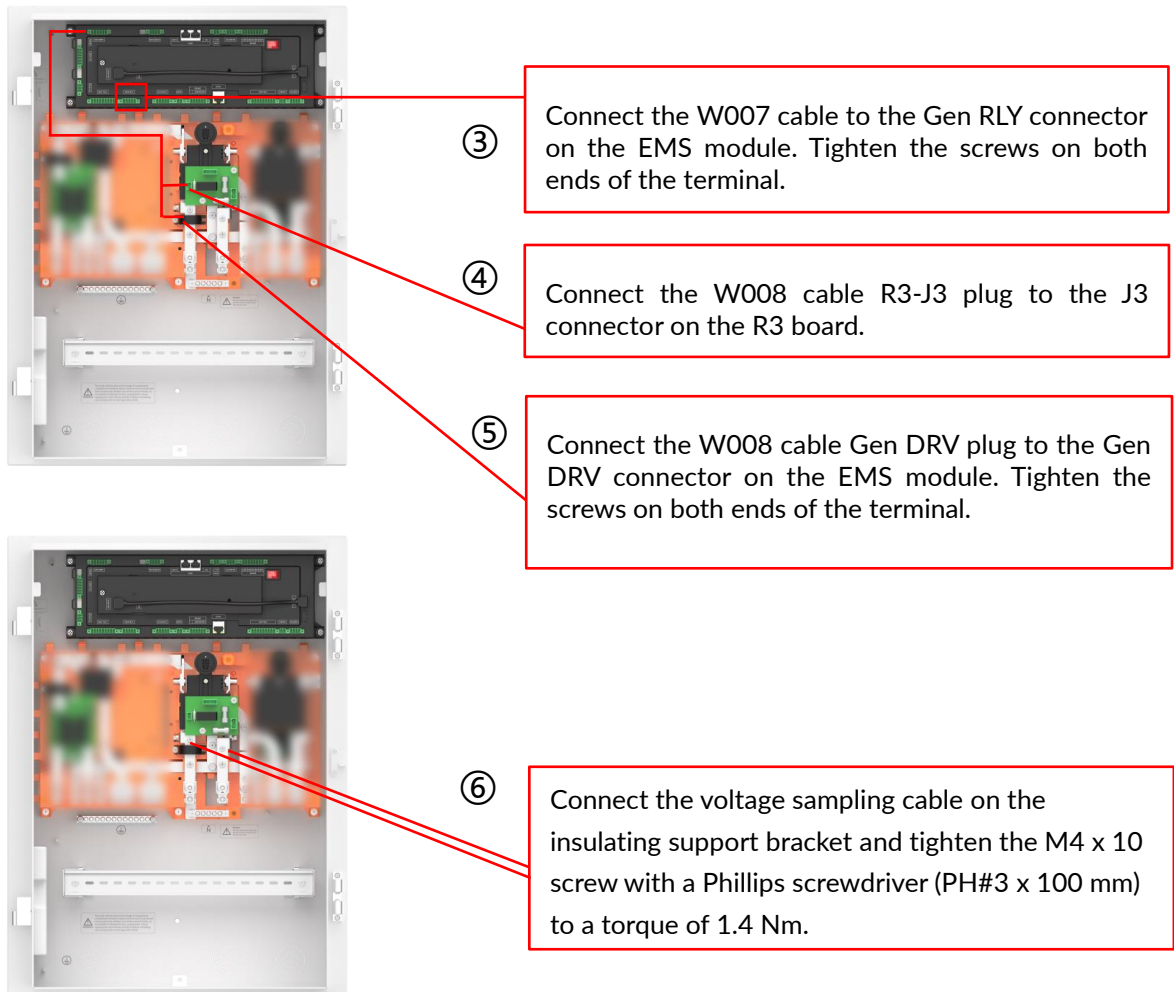

Take the following image for close-up wiring reference. **Do not wire J1 port, J2 port and J3 port before connecting to the generator** (one type of the voltage sensing/ ATS / Dry Contact), use cable tie to tie J1&J3 cable neatly for later generator wiring.

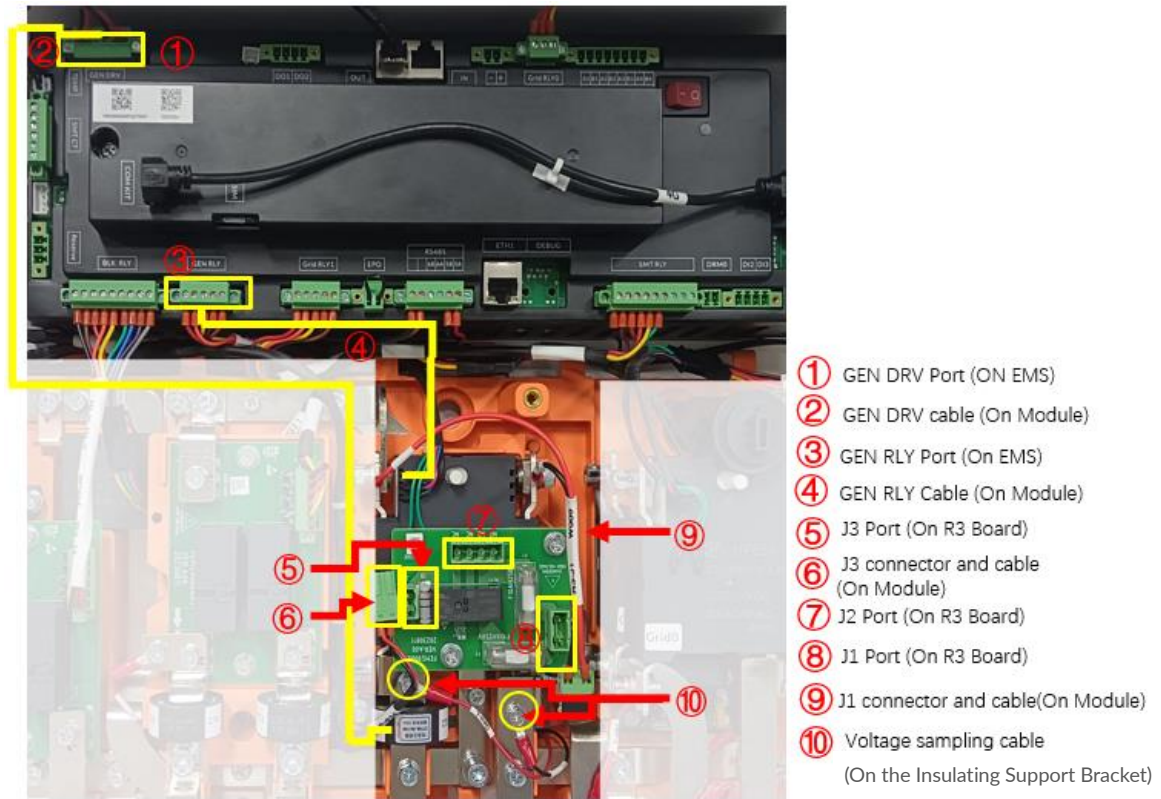

4) If the generator is not ready to wire to, then finish the installation by re-installing the protective cover and fasten the four M5 captive screws using an electric screwdriver, and then tighten them to the recommended torque using a Phillips head screwdriver.

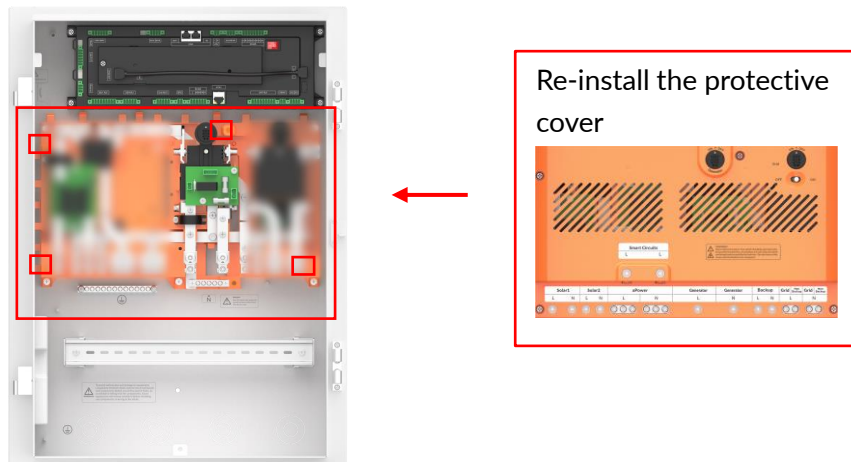

Connecting the Generator

There are three wiring plans, depending on the type of generator.



NOTE:

If aluminum cables are used, the cable connectors need to be treated using antioxidant.

Type 1: Voltage Sensing



NOTE:

Due to differences in various generator types, the wiring diagram is for reference only. Refer to the specific generator instructions for actual wiring requirements.

- i. Connect the generator power output wires (L, N, GND) to the generator input terminals on aGate (L, N & GND).
- ii. Follow these steps for connection:
 - b1. Plug R3-J1 cable to J1 port on the generator module board.
 - b2. Plug R3-J3 cable to J3 port on the generator module board.
 - b3. Remove the original voltage sensing port cable from the generator and strip the sensing cable around 4mm then connect to the 2 NC pins of J2 port provided in the accessories package.
 - Used cables ranging from 1 mm² to 2.5 mm² according to local regulations or AS/NZS3000.
 - Make sure to connect the generator's starting battery charge terminal in the generator to the wire from a branch circuit of the Backup Panel.

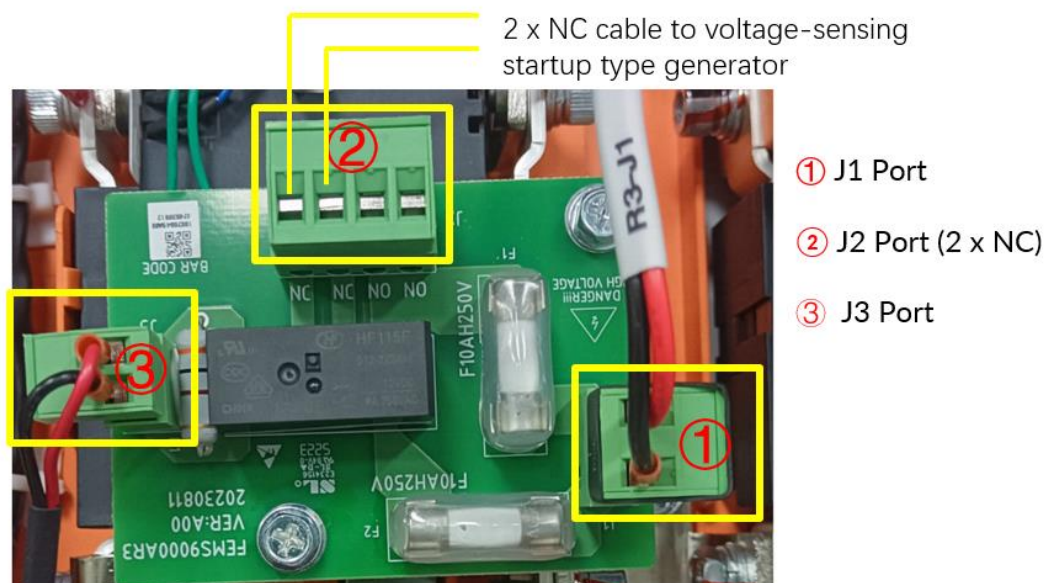



NOTE:

A secure connection must be kept between the battery charge terminal and the Backup Panel branch terminal, whether the generator is on or off. Do not plug short terminals in the shipping attachment into any interface on the R3 board.

Type 2: ATS

- i. Remove the power grid input cable from the power grid port on the ATS.
- ii. Connect the grid input cables to the grid terminals (L, N & GND) in aGate.
- iii. Connect the output terminals of the generator system to the generator input terminals on the aGate.
- iv. Follow these steps for connection:
 - 1. Plug the R3-J1 cable to the J1 port on the generator module board.
 - 2. Plug the R3-J3 cable to the J3 port on the generator module board.
 - 3. Remove the original voltage sensing port cable from the generator and strip the cable around 4mm then connect to the 2 NC pins of J2 port provided in the accessories package.

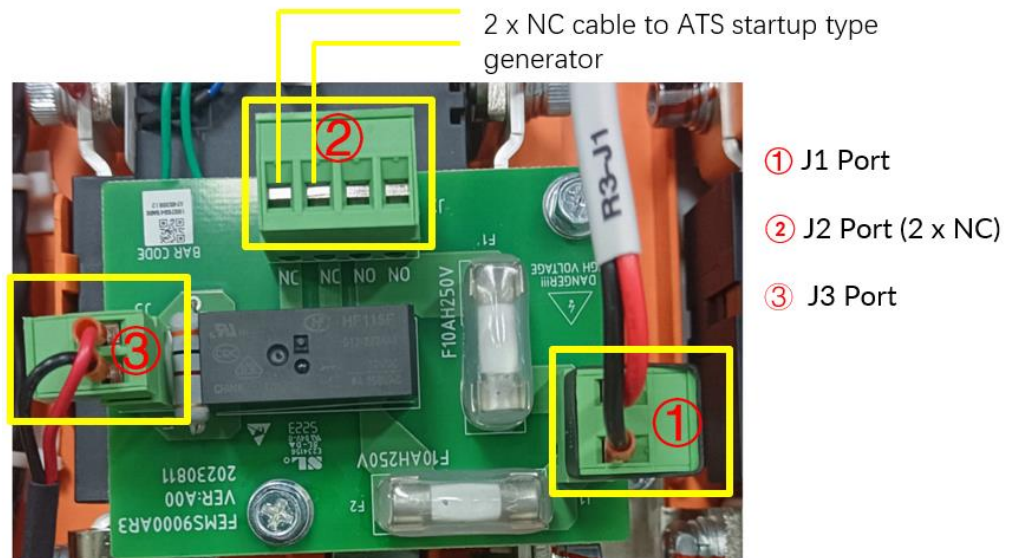

NOTE:

Do not plug short terminals in the shipping attachment into any interface on the R3 board.

Use cables ranging from 1 mm² to 2.5 mm² according to local regulations or AS/NZS3000.

Type 3: Dry Contact

- i. Connect the generator power output wires (L, N, GND) to the aGate generator input terminals (L, N, GND).
- ii. Follow these steps for connection:
 1. Plug the J1 Port by using the short-circuit J1 port from the accessories package.
 2. Plug the R3-J3 cable to the J3 port on the generator module board.
 3. Remove the original startup cable from the generator and strip the cable around 4mm then connect to the 2 NO pins of the J2 port provided in the accessories package.
 4. Used cables ranging from 1 mm² to 2.5 mm² according to local regulations or AS/NZS3000.
 5. Connect the generator's starting Battery Charge terminal in the generator to the wire from a branch circuit of the backup Panel.

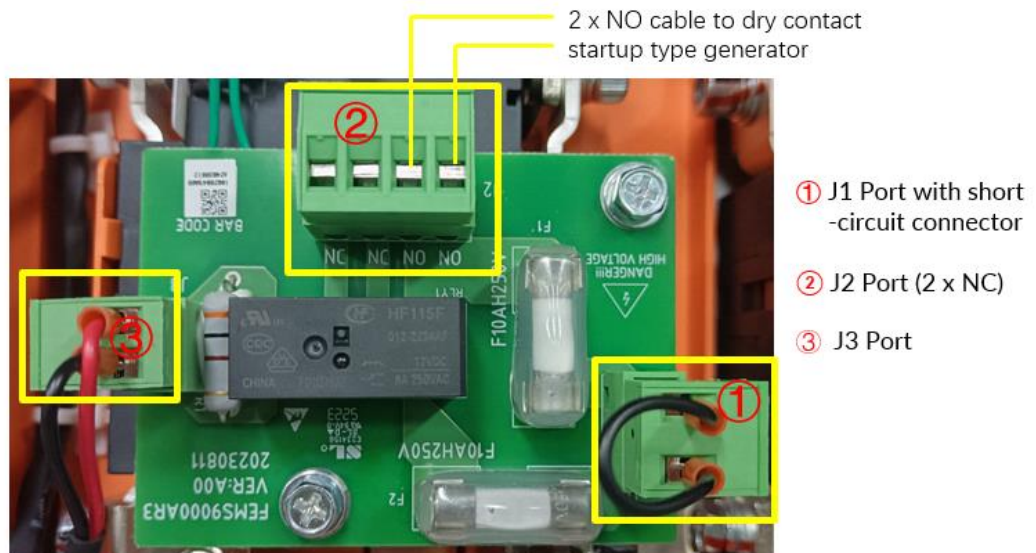

NOTE:

The connection must be kept between the Battery Charge terminal and the Backup Panel branch terminal, whether the generator is on or off.

Do not insert the R3-J1 terminal reserved for the aGate into any interface on the R3 board.

Install Breakers as Needed

The below image shows the location of each breaker for reference.

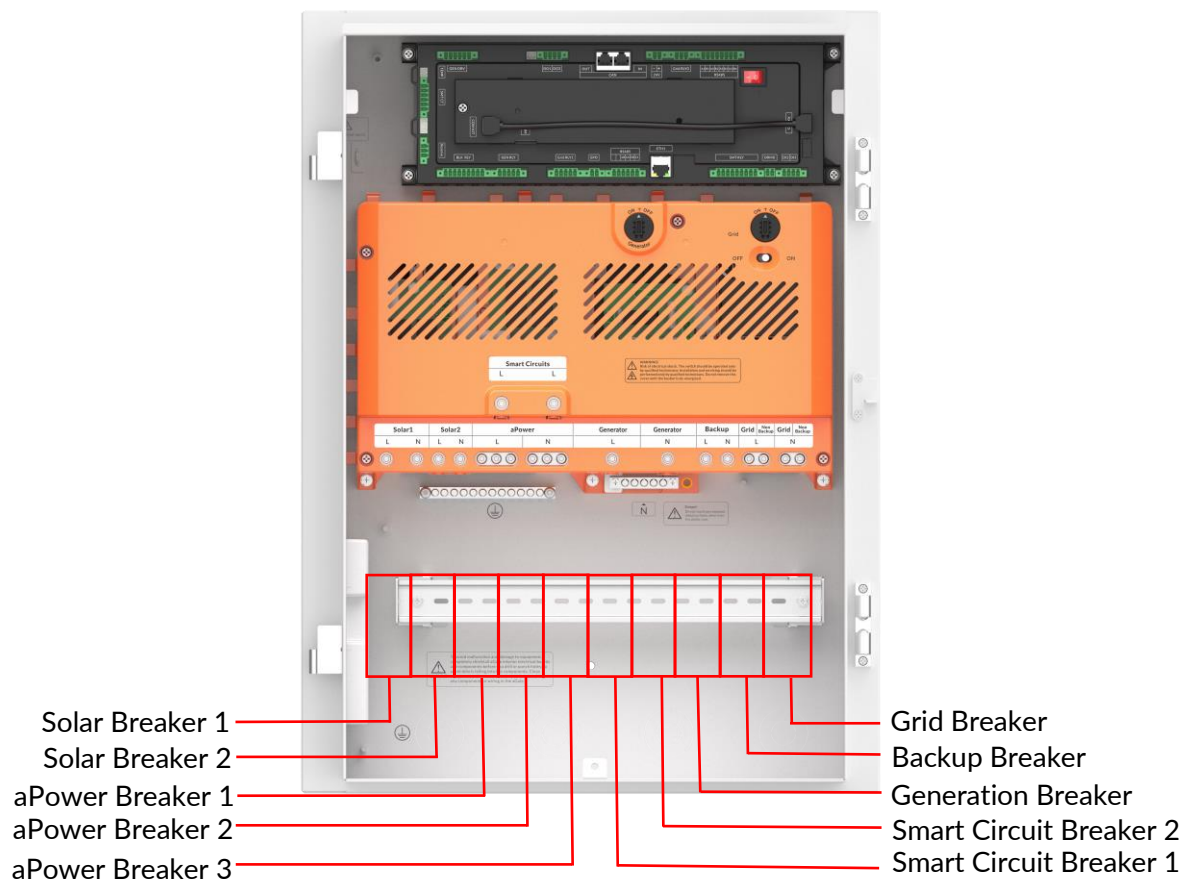

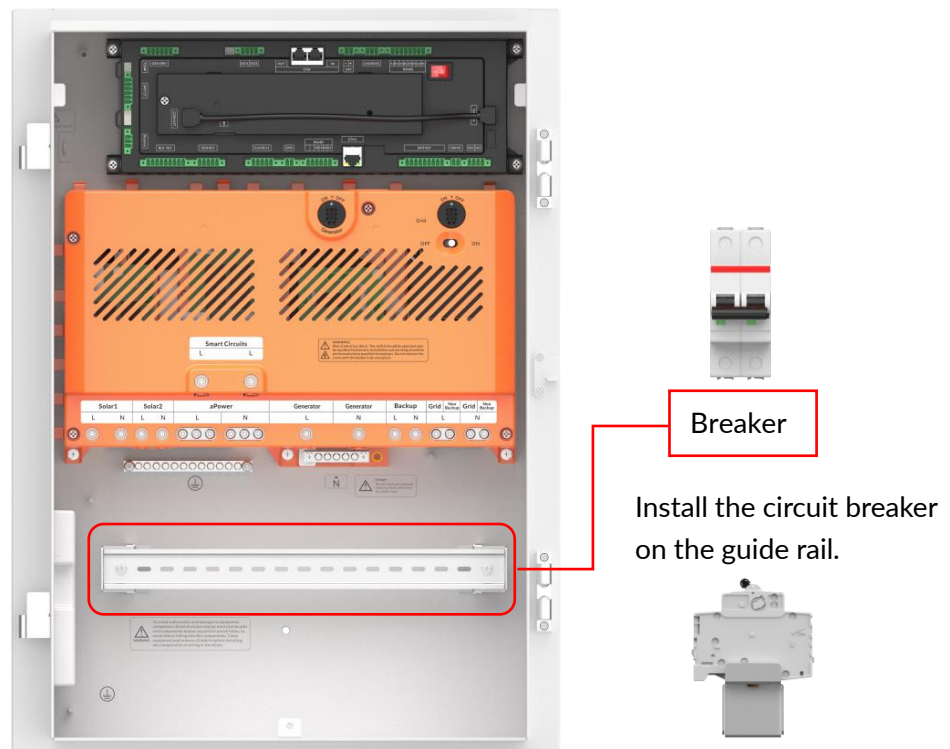

After the installation is complete, remove the baffle plate from the corresponding circuit breaker position on the inner door panel, and attach the appropriate label to the door panel as shown below.



Name	Max Overcurrent Protection	Rated Short-Circuit Capacity	Recommended Brands
Grid	100 A	10 kA	ABB/Clipsal/Hager
Generator	100 A	6 kA/10 kA	ABB/Clipsal/Hager
Backup load	80 A	6 kA/10 kA	ABB/Clipsal/Hager
Non-backup load	63 A	6 kA/10 kA	ABB/Clipsal/Hager
aPower	32 A	6 kA/10 kA	ABB/Clipsal/Hager
Solar	63 A	6 kA/10 kA	ABB/Clipsal/Hager
Smart Circuits	63 A	6 kA/10 kA	ABB/Clipsal/Hager

**NOTE:**

- The recommended breaker brands are for reference only. The breaker should meet the requirements of AS/NZS 60898 and local regulations.
- Single Pole circuit breakers are acceptable for use.
- The aGate's utility grid circuit breaker is only required where there are no other circuit breakers protecting the conductors feeding the aGate's utility grid connection.
- Solar has two inputs, but the total power should not exceed 15 kW.
- Smart Circuits have two outputs, but the total power should not exceed 15 kW.
- The short-circuit breaking capacity of the grid MCB should be at least 10 kA.
- The generator break may be installed outside the aGate depending on the site condition.

Mount the aGate on the Wall

Follow the procedures below to install the aGate on the wall.



DANGER:

Avoid drilling holes in water pipes and cables in the wall.



WARNING:

If you have installed the aPower and are installing the aGate above, cover any nearby aPower ventilation grills and/or heat dissipation holes during drilling to protect from gravel dust.

- The following are the basic steps for installing the aGate on concrete or brick structures:

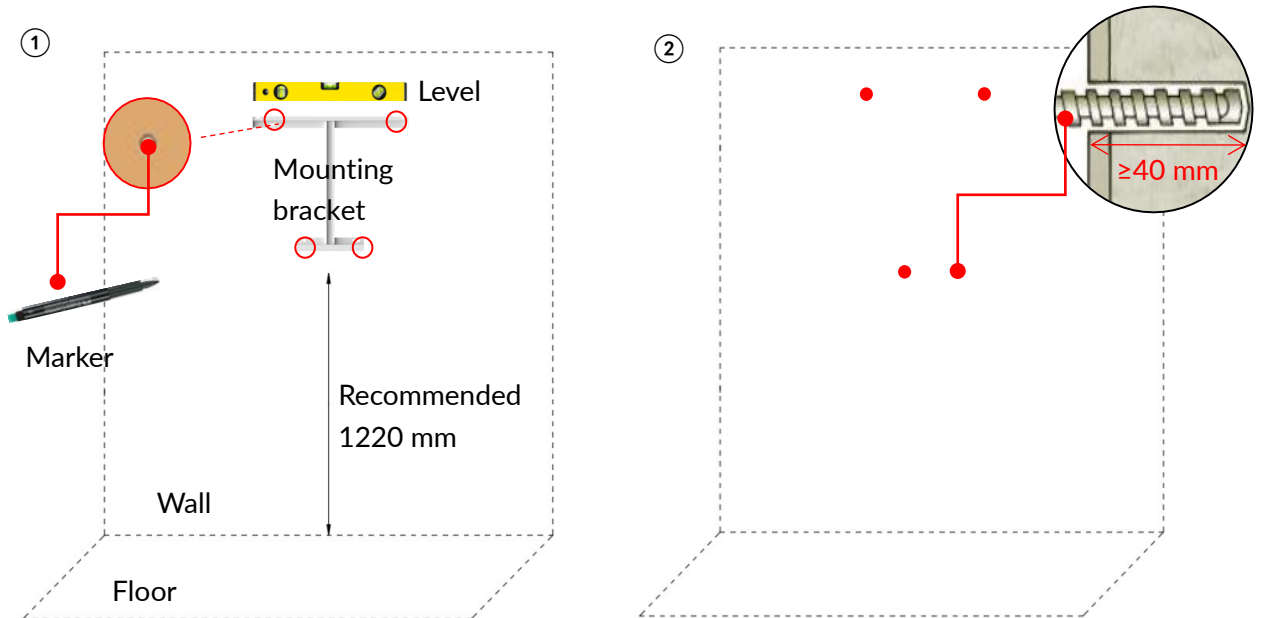

① Place the mounting bracket at the planned installation position (refer to the local laws, regulations and codes in relation to building construction for the minimum mounting height for the aGate). Use a level to adjust the guide board to level, and then make marks at the four holes on the mounting bracket.

② Using an appropriate drill bit for the type of wall (reference below), drill holes the same diameter as the anchor diameter, and at least 40 mm deeper than the expected embedment. Ensure that all fasteners are at least 40 mm away from the edges of masonry blocks or bricks. Clean debris out of the holes.

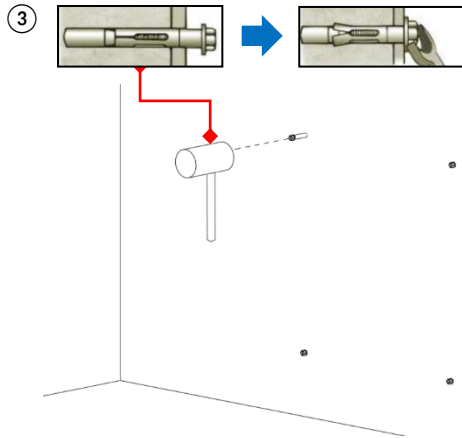

③ Use a 10 mm socket to unscrew the screw counterclockwise.

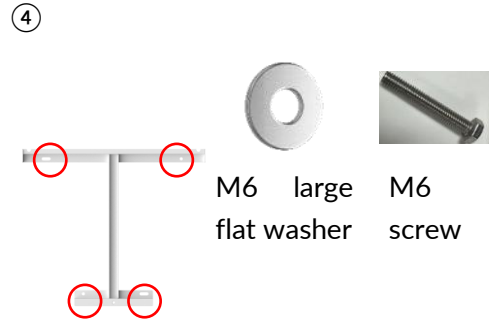

④ Fasten the aGate brackets to the wall using the fittings: M6 large flat washer and M6 screw. Check that the tightening torque is 6.0 Nm.

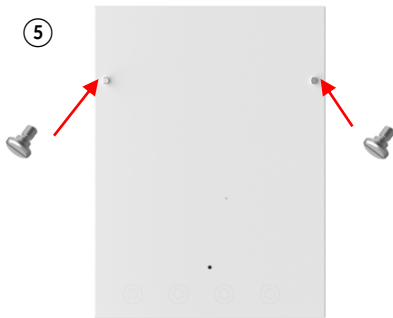

⑤ Remove the slotted screws from the shipping package, and fixed them on the back of the aGate as shown in the figure.

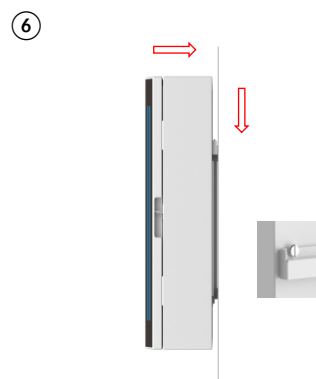

⑥ After fixing the slotted screws, the aGate should be hung on the wall brackets as shown in the figure (all slotted screws should be firmly connected to the brackets).

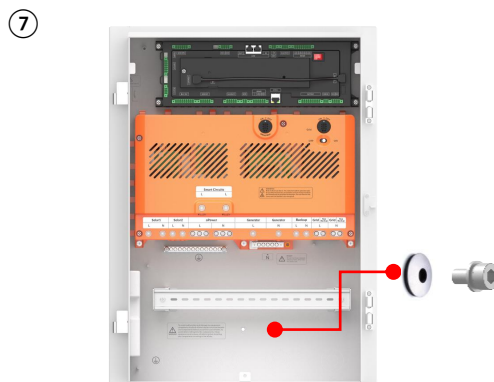

⑦ After hanging the aGate, secure the fastener to the bottom bracket from the inside of the chassis using M6 hexagon socket screws.

- The following are the steps for installing the aGate on wooden beams:

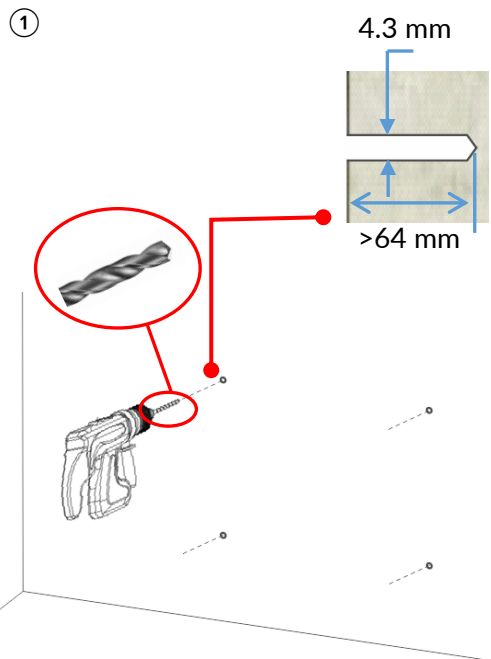

- ① Select an appropriate drill bit to drill holes at the marked points. The diameter of the holes should be 4.3 mm and the depth of the holes should be at least 64 mm. Remove debris from the holes.

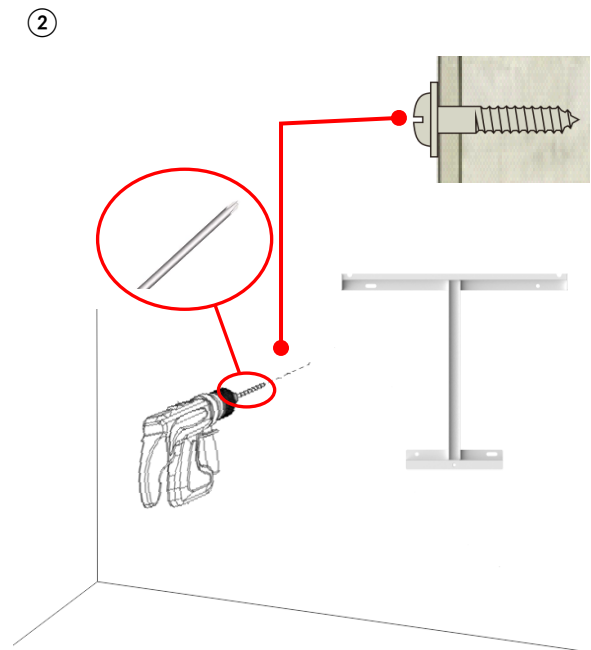

- The following are the steps for installing the aGate on steel beams:

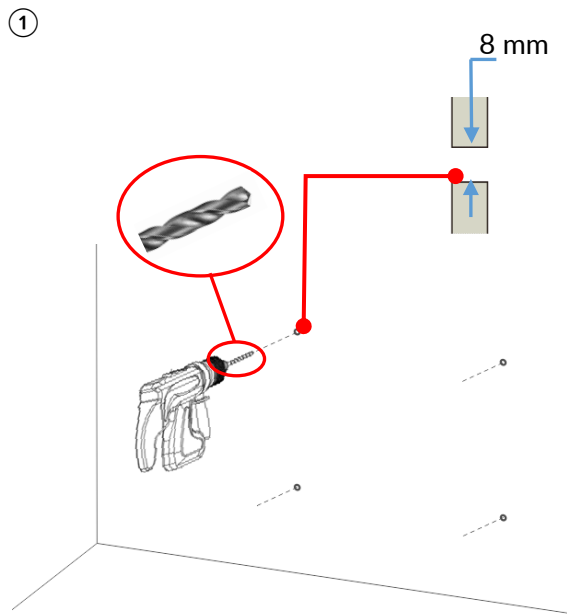

① Select a suitable drill bit to drill holes at the marked points. The diameter of the holes should be 8 mm and the depth of the holes should be through the steel beam. Remove debris from the holes.

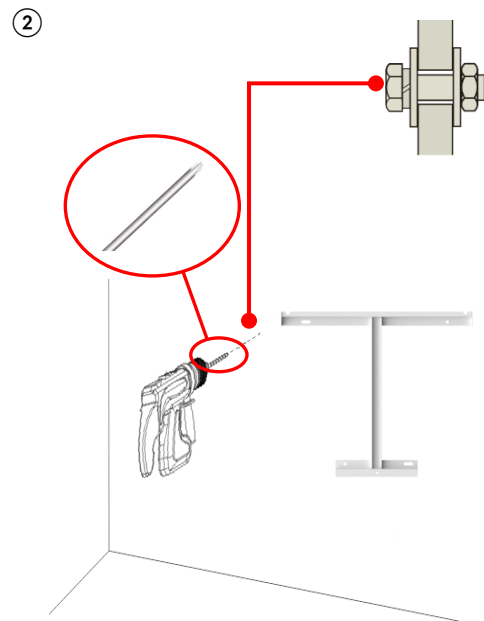

② Use M6 stainless steel hexagon screws with spring washer and large flat washer and hexagon nuts to fix the support to the steel beam holes. Tighten to with a force of 6.0 Nm.

Electrical Conduits and Wiring

Electrical Conduits

Open the wiring compartment cover on the aPower

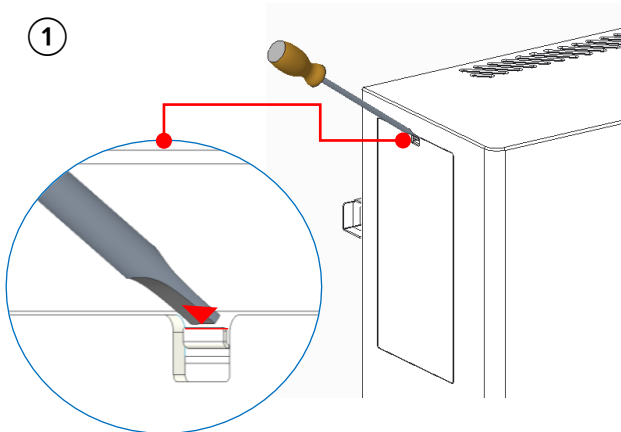

① Use a 6 x 100 mm flat head screwdriver and insert it into the snap joints, press and pull the cover out.

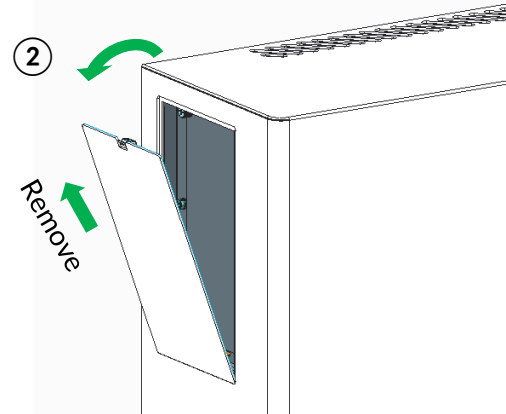

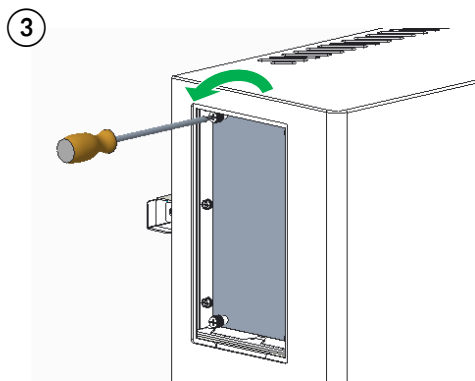

② Lift the cover upward.

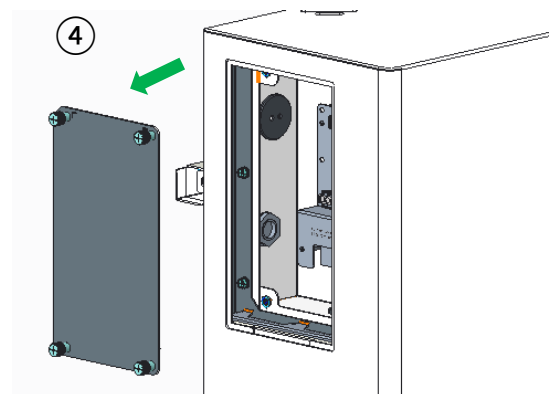

③ Remove screws fastening the internal panel. Turn them counterclockwise using a #3 x 100 mm Phillips head screwdriver.



④ Remove the cover.

Incorrect operation may lead to thread galling, which will damage the aPower and the screws cannot be loosened.

Remove aPower Accessories

- Unplug the 2 external charging cables.

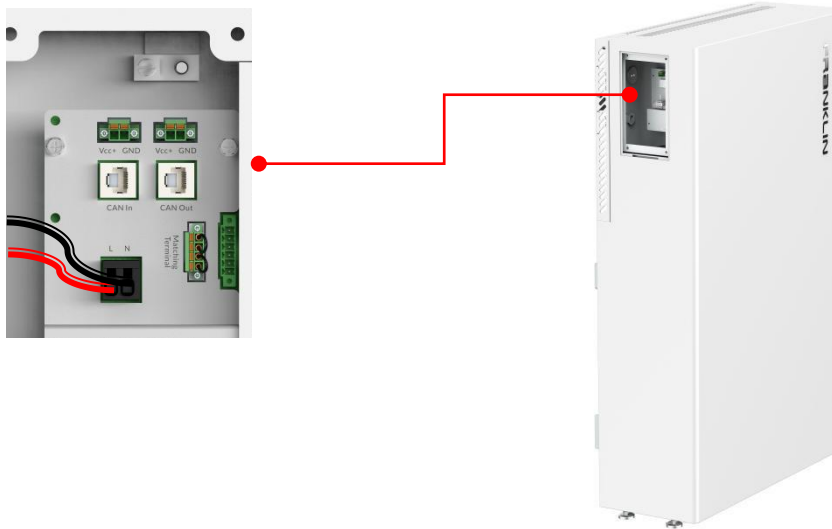

- Select an appropriate cable entry hole for conduit installation.
- Remove the protective ring from the small entry hole.

If the small entry hole is selected for wiring, proceed with the conduit adaptor installation.

If the large entry hole is selected for wiring, seal the small entry hole with the included cable conduit hole-plug for safety reason.

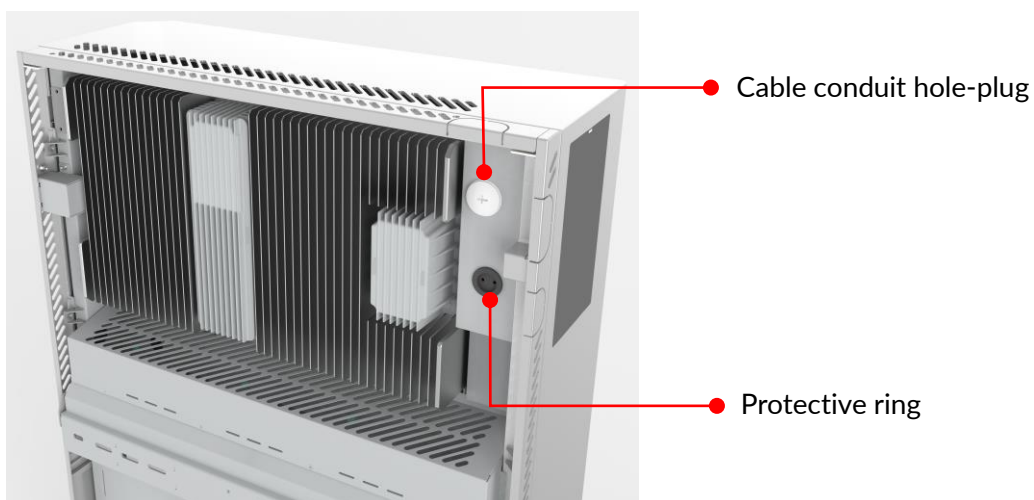

Install Conduit Adaptor to the aPower Cable Holes

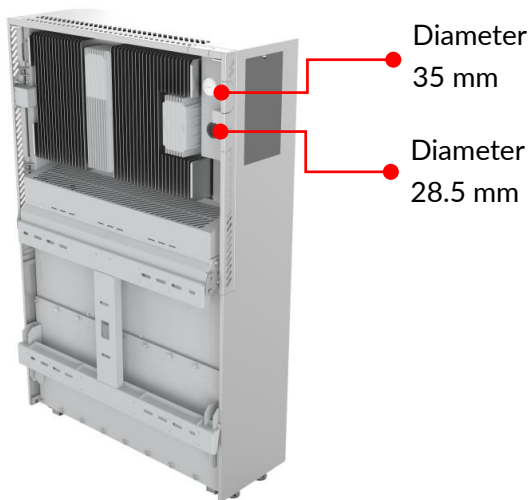

① Select an appropriate conduit adaptor.

- Select a 32 mm diameter plug for the 35 mm hole
- Select a 25mm diameter plug for the 28.5 mm hole

② Install the corresponding plug into the corresponding hole. The threaded end of the plug screws into the hole on the back of the aPower.

(The figure below is for reference.)

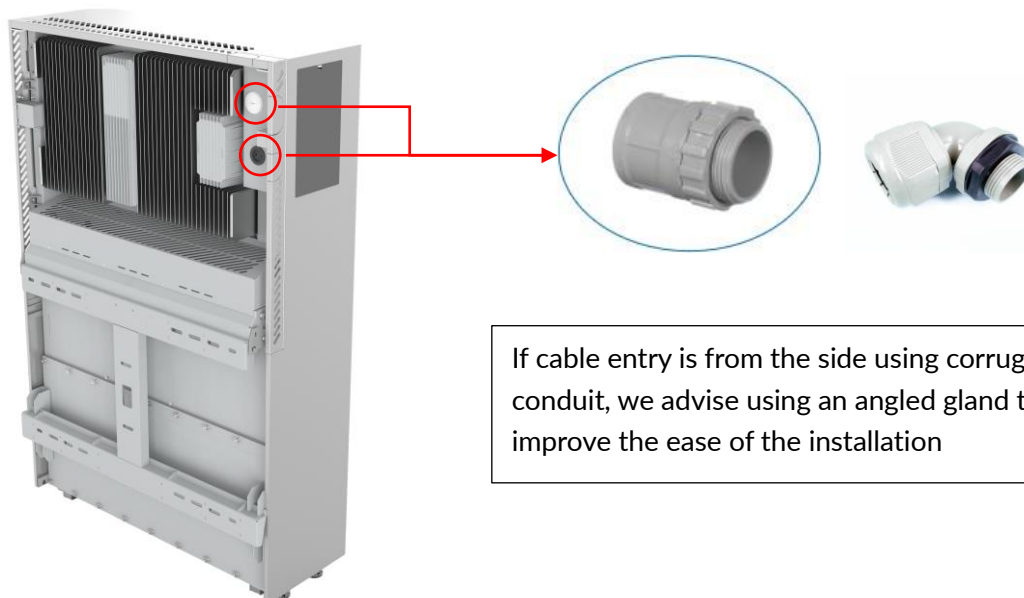

Communications Wiring

Connect a Wi-Fi Com Kit cable to activate the aGate commissioning functions

Ensure that the Wi-Fi Com Kit properly connects the Wi-Fi module to the EMS. If the 4G module is configured, please refer to *4G Data Plan Operating Manual*.

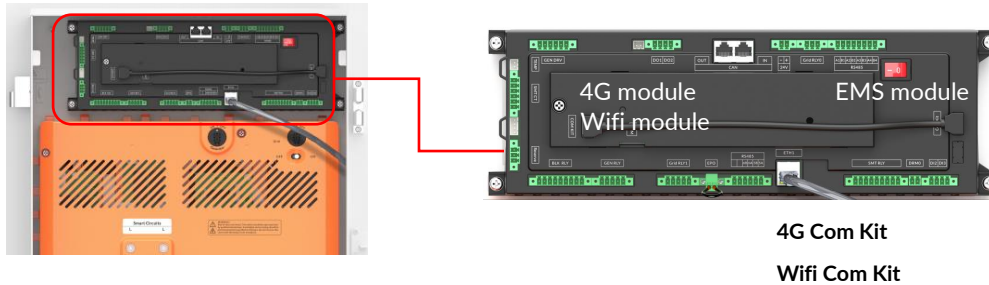

- ⚠
- Only use the cable supplied with the equipment.
- The aGate cannot be activated if this step is not completed.

Establish communications between the FranklinWH App and the aGate

- Connect your mobile device (smart phone or tablet) to the built-in Wi-Fi access point in the aGate to establish a local connection.

The built-in Wi-Fi access point (AP) provided by each aGate may be used to establish local communications between the FranklinWH App and the aGate.

- Account: AP_XXXXXXXXXX (last 9 digits of serial number), Password: last 12 digits of the serial number (The serial number is on the QR code of the EMS).

NOTE:



After commissioning, the account and password can be modified through the FranklinWH App.

- Connect the aGate to the home network for remote access.
 - Method 1 (Recommended): Connect the aGate to the household network using an Ethernet communications cable (Not provided).

To ensure the reliability of remote communications, it is recommended to connect the household network cable with internet connection to the **Eth1** port of EMS module, in order to enable the remote communication function.



- The cable from the household network may only be connected to the Eth1 port.
- The communications cable needs to be made on site using a crimping tool, a ready-made network cable should not be used. Otherwise, the bending of cable inside the aGate may prevent the internal cover from closing. Test with a network cable tester to ensure that the cable contact is error-free.

Communications cable preparation:

- ① Remove the insulation jacket from the cable.
- ② Fan the wires in the order of 568B (See wiring scheme diagram).
- ③ Insert the wires into the connector.
- ④ Crimp the connector using a crimping tool and then the cable is ready.
- ⑤ Test with a network cable tester to ensure that the communications cable contact is error-free.

Before testing the cable, ensure that both ends of the cable are disconnected from the FranklinWH system.

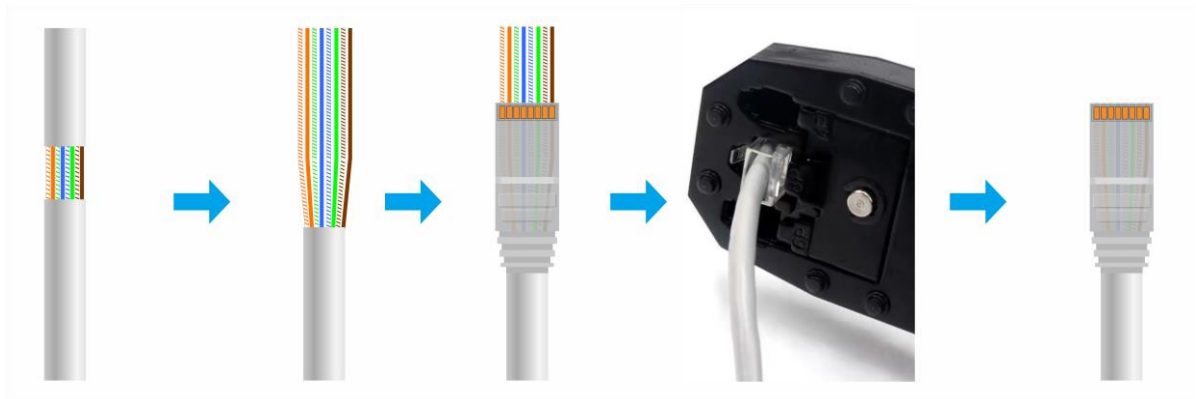

Wiring scheme:

The communications cable wiring must conform to the **568B standard sequence**.

- Pin 1: white/orange,
- Pin 2: solid orange,
- Pin 3: white/green,
- Pin 4: solid blue,
- Pin 5: white/blue,
- Pin 6: solid green,
- Pin 7: white/brown,
- Pin 8: solid brown.

RJ-45 Pin	1	2	3	4	5	6	7	8
Pair	2	2	3	1	1	3	4	4

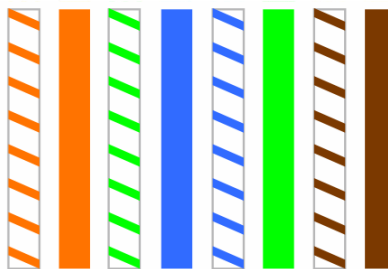

TIA/EIA-568-B

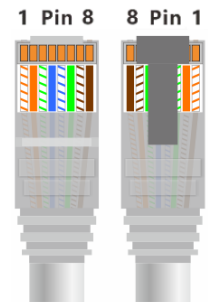

➤ Method 2: Connect via Wi-Fi

The Wi-Fi connection between the aGate and household wireless network should be done during commissioning. Please refer to the *FranklinWH System Commissioning Guide Using App*.



***NOTE:** The aGate supports only 2.4Ghz Wi-Fi connection to the family router.

➤ Method 3: Connect via telecommunication 4G network (only as backup).

Please make sure that there is a good 4G LTE signal in the local area and that a SIM card has been inserted into the slot on the wireless module.



Communications connection between the aGate and the aPower

Before connecting the communications cable to the FranklinWH system, test it with a network cable tester to ensure that the cable contact is error-free.

WARNING:



When multiple aPower units work in parallel, it is necessary to remove the excess matching terminals from all aPower units along the connection except for the matching terminal on the last aPower .

NOTE:



It is recommended to install the communications cable in the conduit to avoid accidental damage and equipment failure. If the network cable and the power cable share the same conduit, use a shielded network cable (RJ45 cable end with metal).

- When distance between the aGate and the first aPower is shorter than 30m, only a network cable is required to connect the aGate and aPower.

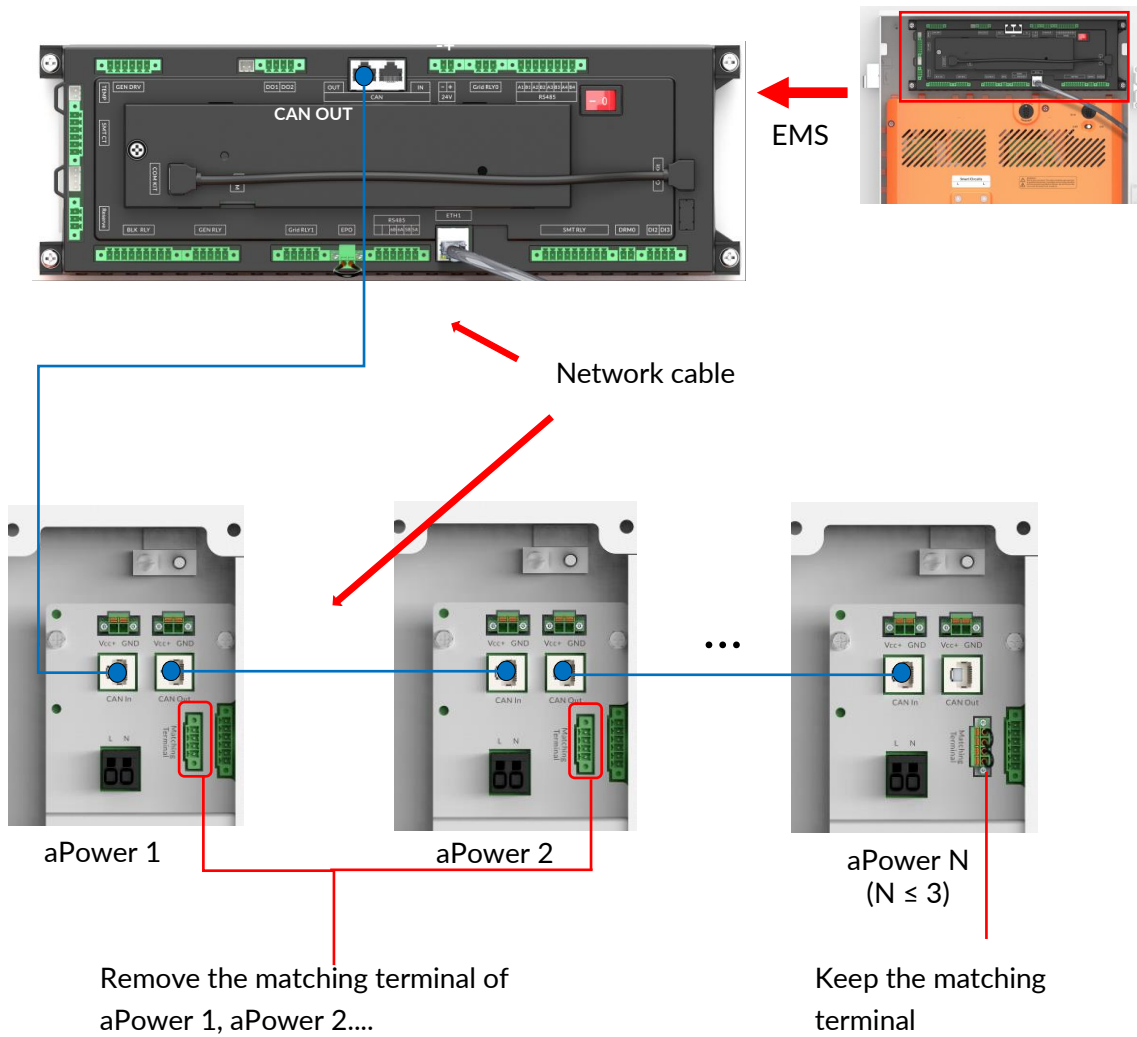

***NOTE:** For network cable production, please refer to *Communications cable preparation* above or *Communications Cables*.

- When the distance between the aGate and the first aPower is longer than 30m, both a network cable and a 20V power supply cable must be used.

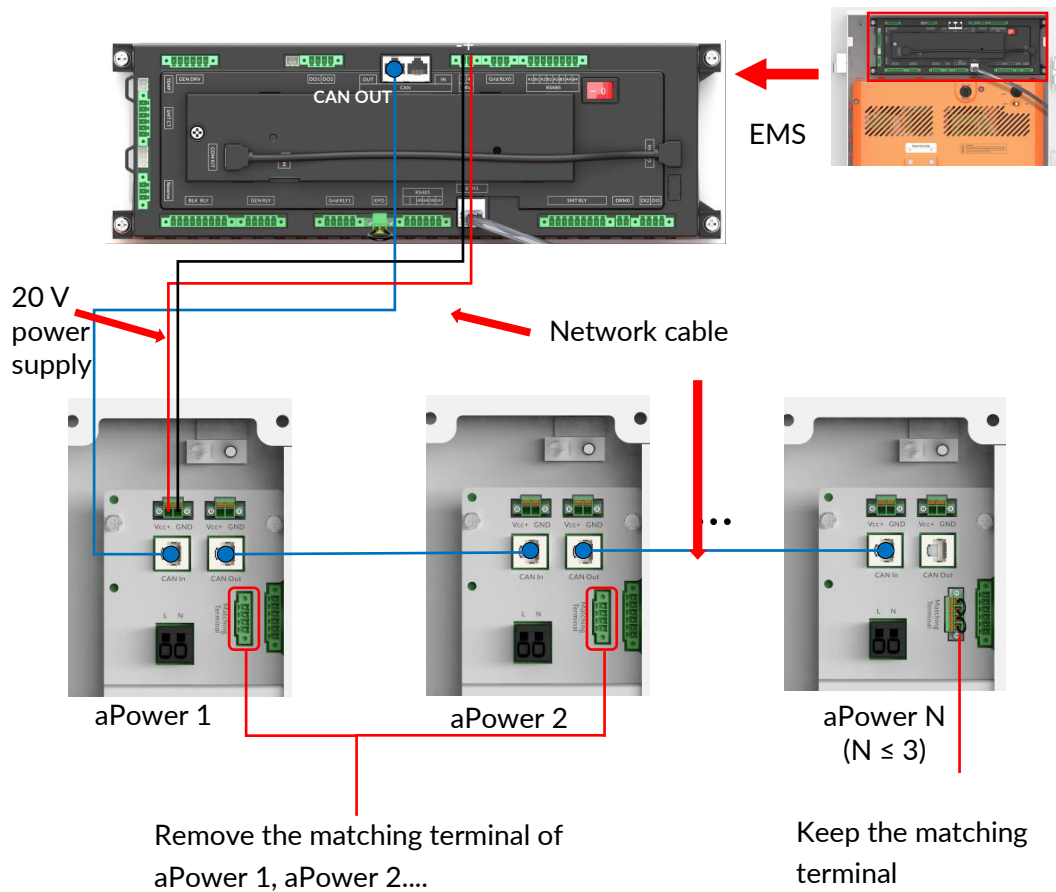

When the system needs to be connected to the 20 V power supply, the terminal does not need to be removed. Just press the orange switch on the port, insert the prepared wire, and then release the switch to complete the wiring.

The 20 V power cable preparation:

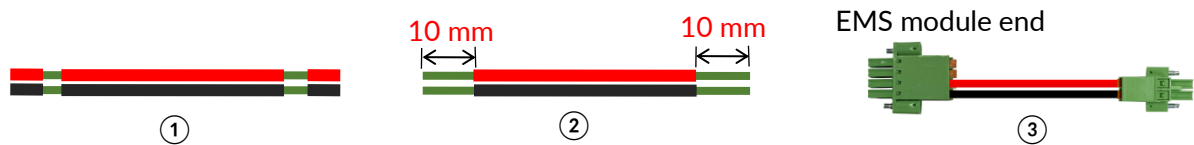

- ① Run the 1-1.5 mm² 20 V power cable through the electrical conduit. Refer to the local regulations for the cable colors.
- ② Remove the insulation jacket on both ends by 10 mm.
- ③ Remove the VCC plug from the CAN Out terminal of the aPower battery terminal enclosure and use to connect 24V+/- terminal in the aGate. Only 1 power connection between aPower batteries and the aGate is required no matter how many batteries are present
- ④ Connect the wires to the corresponding terminals.

RS485 communications and DRM0 signal control

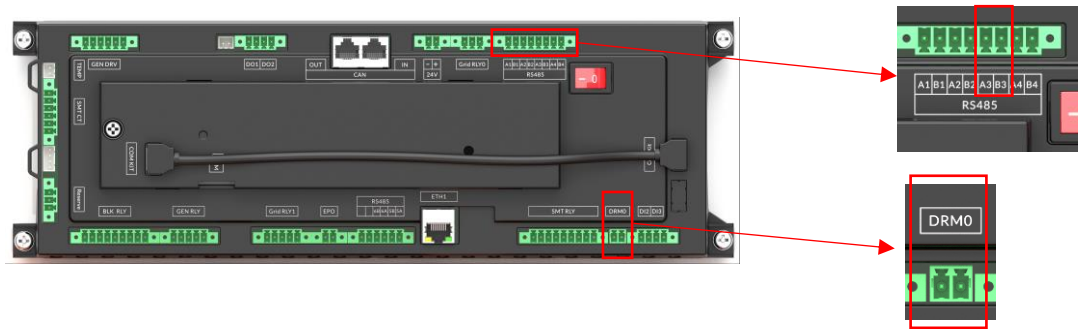

If you need to force a system stop, please short the DRM0 port. The above operations are only performed by qualified professionals. Connect the external cable to the A3/B3 ports on the RS485 communications port to check the power supply of the grid.

Electrical Wiring

aGate Terminal Information

NOTE:

- The wiring should comply with AS/NZS 3000, local laws and regulations, and site application.
- Use 1-pole or 2-pole MCB depending on local laws and regulations and specific site application.
- The wiring of breakers should follow the specific breaker instructions.
- The power sources must be connected to the aGate at the corresponding ports.

WARNING:



Installers should assess if Surge Suppression Devices should be installed on the installation. Advice is provided in AS/NZS 3000 Appendix F

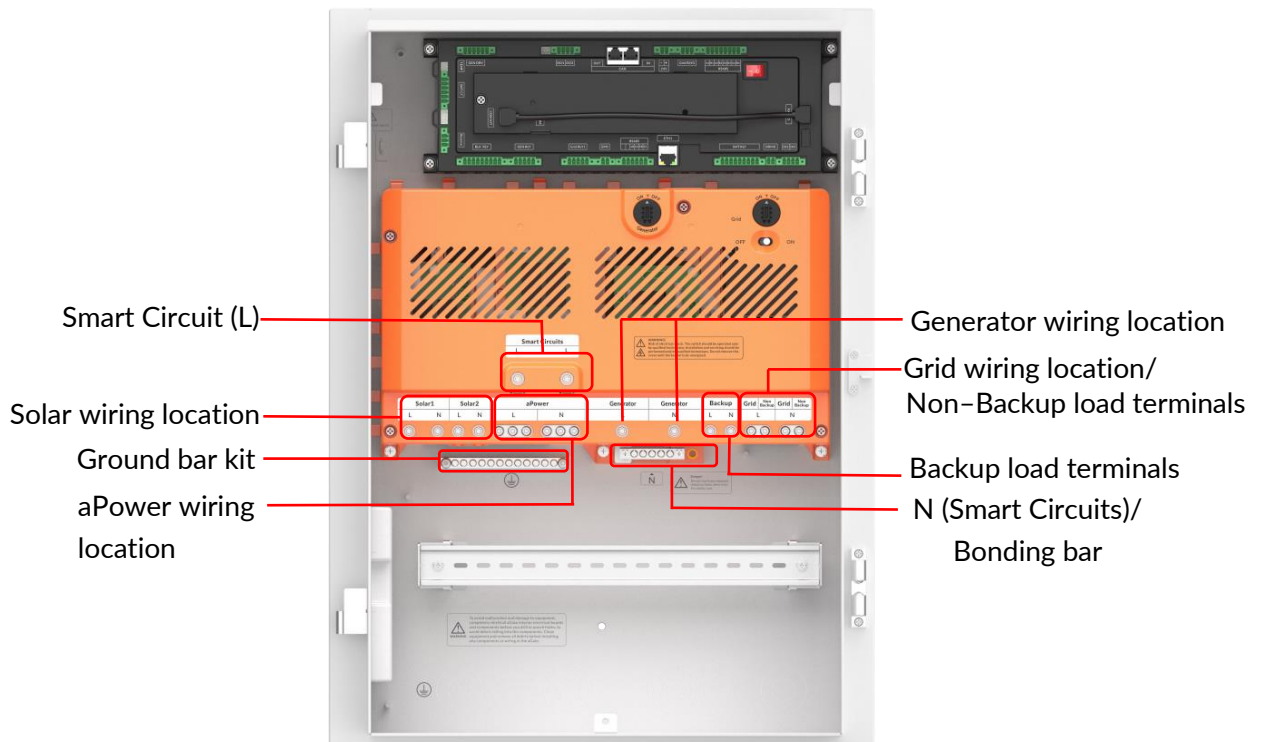

Location	Applicable Cable	Wiring Torque	Stripping Length
Grid	25 mm ²	5.6 Nm	12 mm
Generator	25 mm ²	5.6 Nm	12 mm
Backup	25 mm ²	5.6 Nm	12 mm
Non-Backup	16 mm ²	5.0 Nm	12 mm
Smart Circuits	2.5-10 mm ²	3.9-4.5 Nm	12 mm
aPower	6 mm ²	3.9 Nm	12 mm
Solar	6-16 mm ²	3.9-5.0 Nm	12 mm

NOTE:

- Secure the terminals on the aGate using a 4 mm hex wrench.
- Stripping length is only for the aGate terminals. The stripping length of the circuit breaker terminals, the installation torque, and the tool used are determined by the brand and model of the circuit breaker used onsite.



WARNING:

To comply with the requirements of AS/NZS 3000 Clause 7.3.8.1.1 a – The incoming Neutral SHALL NOT be switched. The neutral cables of the grid side and back-up side must both be connected together to the N-Bar, wiring reference figure below.

A TYPE B RCD IS REQUIRED ON THE aPower X-01-AU and aPower X-02-AU PORTS OF THE INVERTER.

RCD's differential residential current should be 30 mA, type B or A.

The MCB in the distribution box should match the MCB in the aGate.

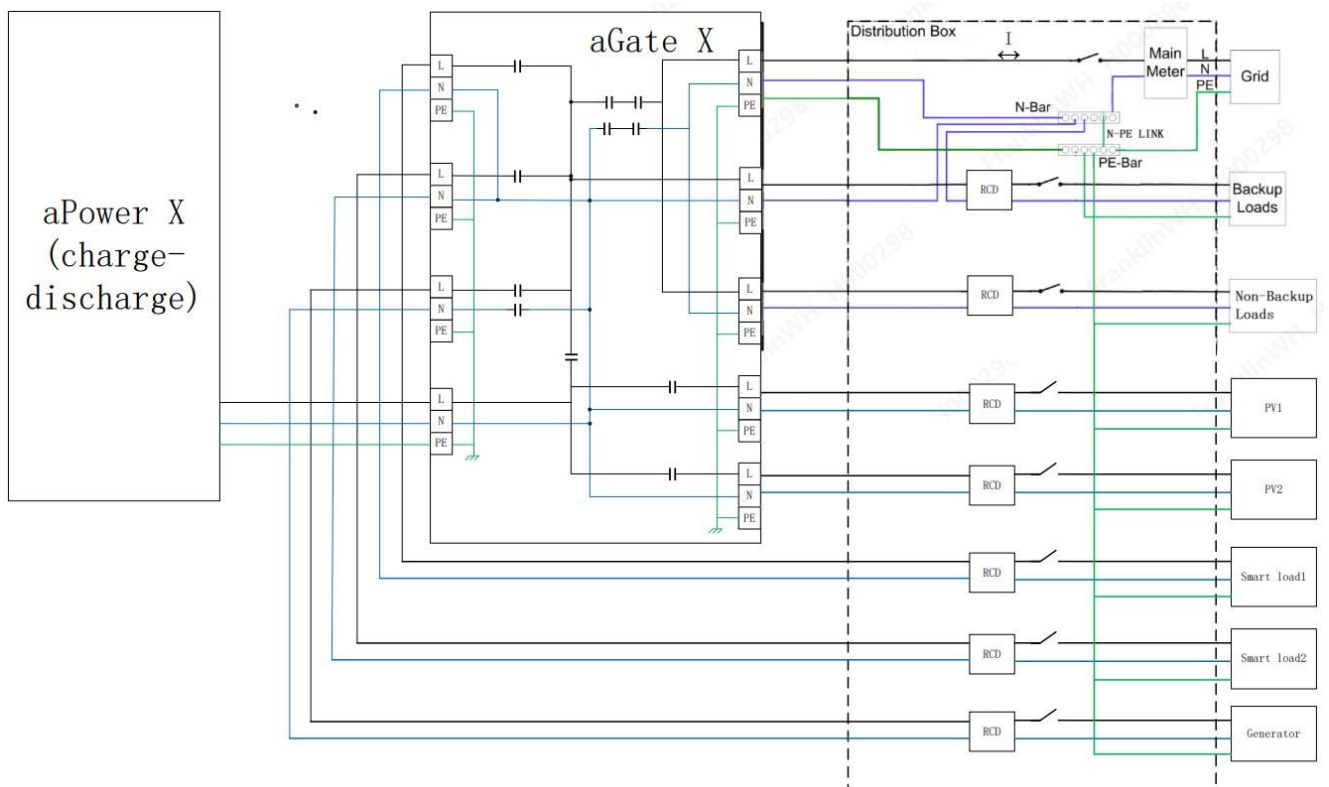

aGate terminal information and wiring requirements are as follows:

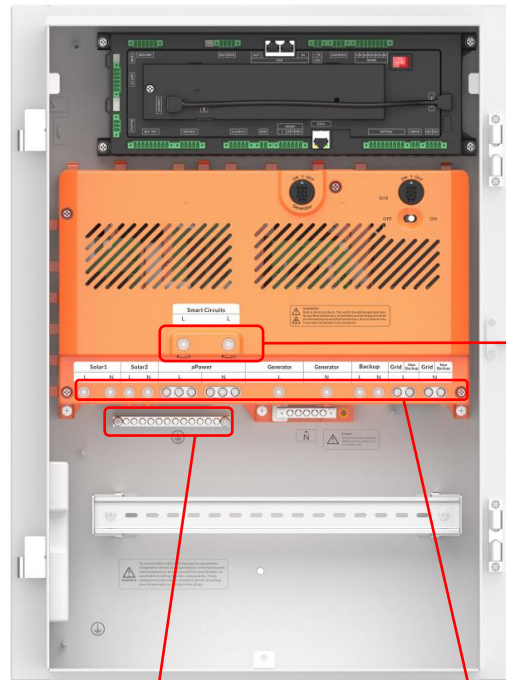

⚠ DANGER: The wiring should comply with AS/NZS 3000 and all local laws and regulations.

Terminal: Aluminum alloy
 Surface Finish: Tinning
 Tool: 3mm Straight screwdriver
 Stripping length: 10 mm
 Applicable cable: 2.5-25 mm² CU
 Wiring Torque: 2.5-6 mm² 3.9 Nm

10 mm ²	4.5 Nm
16 mm ²	5.0 Nm





⚠ DANGER: The wiring should comply with AS/NZS 3000 and all local laws and regulations.

Terminal: Aluminum alloy
 Surface Finish: Tinning
 Tool: 4mm L shaped Allen key
 Stripping length: 12 mm
 Applicable cable: 2.5-25 mm² CU
 Wiring Torque: 2.5-6 mm² 3.9 Nm

10 mm ²	4.5 Nm
16 mm ²	5.0 Nm
25 mm ²	5.6 Nm

General

- The cable conductor sizes and current capacity rating are listed in the standard AS/NZS 3008.1.1 for connection L, N, Ground.
- Conductors, relied upon for the protective grounding and bonding system, will be sized to handle the intended fault currents and, if insulated, the insulation will be green or green with yellow stripes.
- Grounding conductors are sized following section 5 of AS/NZS 3000.
- A field wiring terminal or lead shall be rated for the connection of a conductor or conductors having a minimum carrying capacity rating of 125 % of the rating of the unit.
- The distance between the end of the connection point of a field-installed wire and the wall of the enclosure to ward which the wire is to be directed, shall be following AS/NZS 3000.
- Cables selection will consider metal compatibility.

	<p>DANGER: The power cables should be wired in a sequence of the load side, the backup power supply side, and the non-backup power supply side. If the other end of a cable cannot be wired at the same time, a warning sign Out of Operation, Do NOT Turn On should be hung.</p>
	<p>DANGER: aGate and aPower units do not have any indoor-level lightning protection features. Installers should assess if Surge Suppression Devices should be installed on the installation at the main switchboard. Advice is provided in AS/NZS 3000 Appendix F.</p>
	<p>DANGER: Please follow the Local Precedence rule. Remote control does not mean that the local circuits are safe. Please decide whether your circuit is safe based only on a circuit test.</p>
	<p>DANGER: Electrical connections require that the wires are connected in the correct order, where L and N cannot be misconnected. Incorrect wiring may cause equipment damage or even personal injury or death.</p>

Connecting aPower(s)

- Connecting a single aPower to the aGate

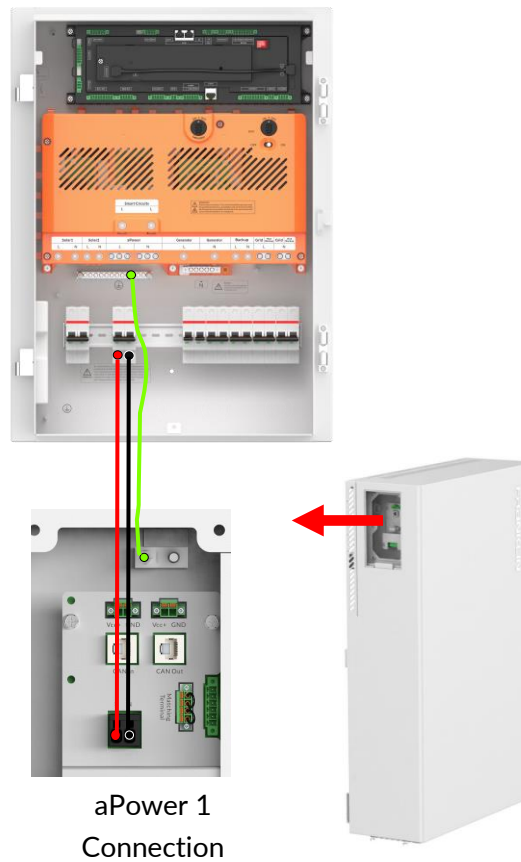

The cable stripping length at the aPower is 15 mm. The cable stripping length at the aGate is based on the circuit breaker requirements.

The cable stripping length
15 mm



- Connecting 2-3 aPower units to the aGate

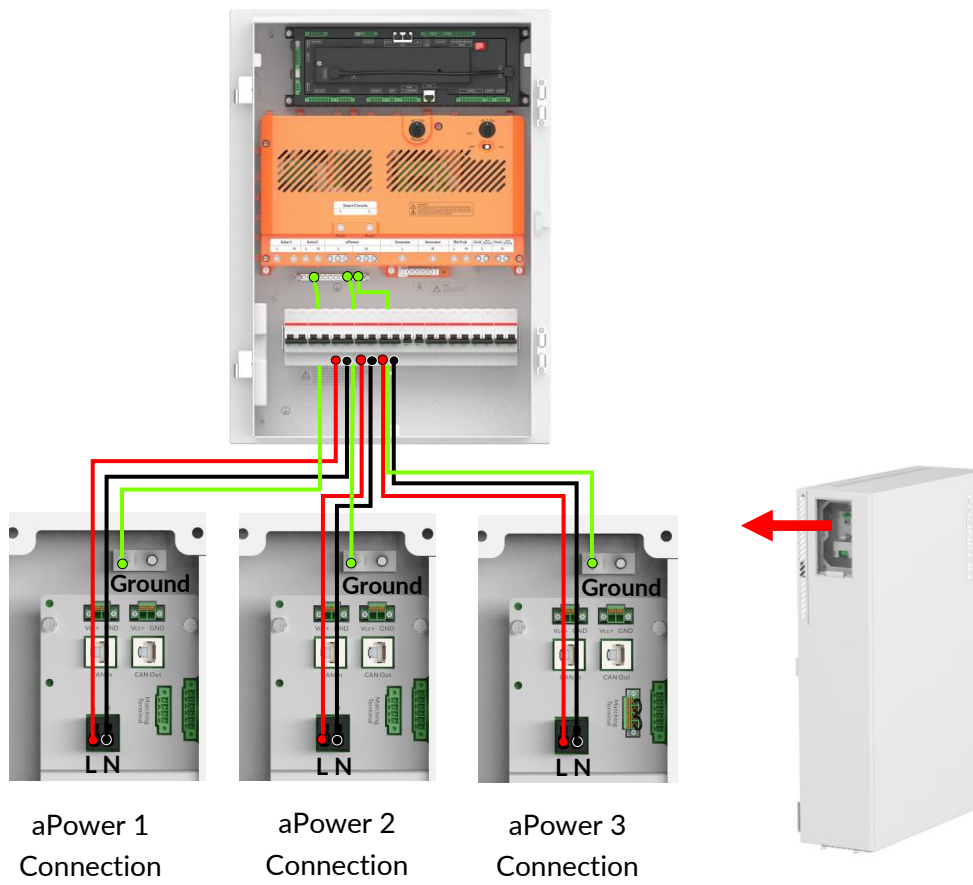

Connecting the Solar Inverter

When connecting a solar inverter to the aGate, the solar breaker is the only interface to be used. Do not connect the solar inverter directly to any other port. The aGate has a built-in solar CT, so that it can directly measure the solar energy generated, and the wires must be connected as required.

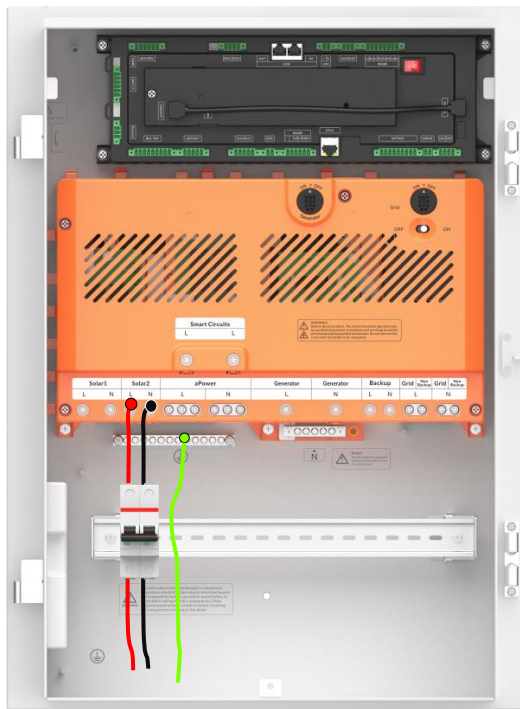

- L
- N
- Ground

 ● The solar breaker is the only interface for connecting the solar inverter to the aGate.

● The aGate has a built-in solar CT.

This installation instruction deals with the Franklin Home Power aGate being installed as a single-phase system. 3Phase Grid and Solar installations are possible. Please contact FranklinWH to be provided with the wiring diagrams.

The unit can be installed for partial home back up in all modes Time of Use and Self Consumption.

Connecting the Grid AC Power

The aGate has an independent grid interface. It can optimize the control of household electricity bills through the EMS. In addition, there is an independent control relay to provide seamless switching of power supply and ensure continuous power supply for the household.

- 1) Install the grid input cable.
- 2) Open the grid CT snap and attach it to the grid L input cable with the CT arrow facing up, then fasten the CT snap and finally plug the CT terminal into the meter L2 CT connector.

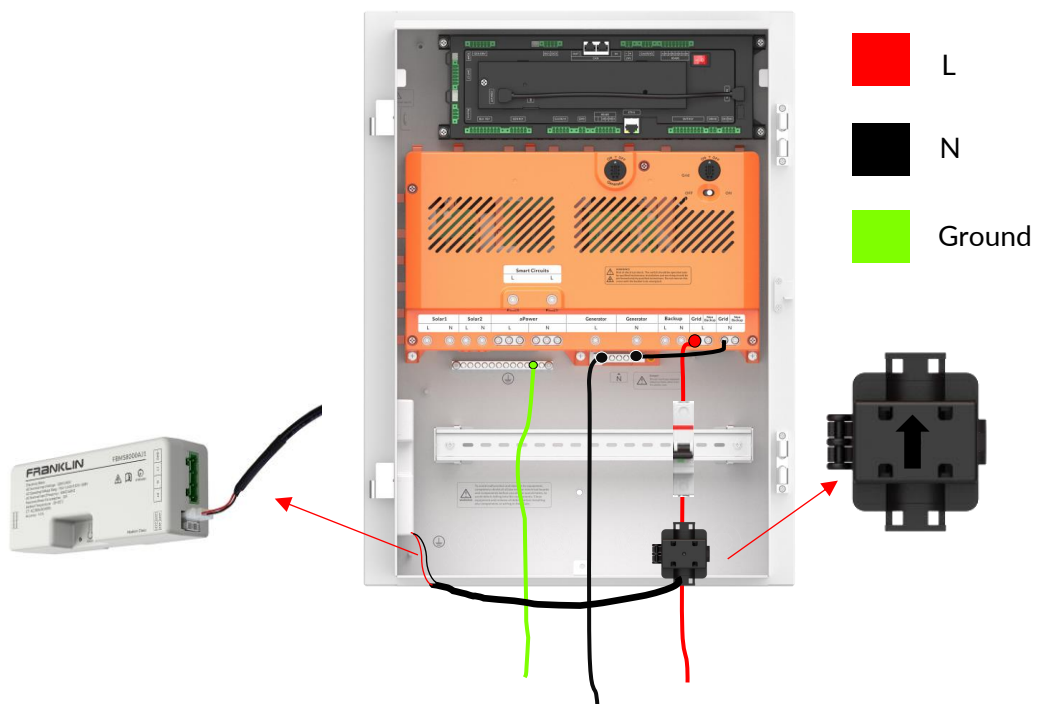

Connecting the External EPO Switch (optional)

When an emergency occurs, such as fire or a smoking battery, the user may manually press the EPO (Emergency Power Off) button to power off the system, where it is safe to do so. The external EPO is an optional component. The homeowner should consult with the installer to have an EPO installed. If an EPO is not needed, skip this step.

Please note the following when choosing the external EPO:

- Must be labeled as "Emergency Stop Button," "Emergency Stop Device," "Emergency Stop Unit."
- Must have an ON/OFF switch that maintains its position after being manually set to either status.
- Must have a clear indication of the ON/OFF positions.
- The maximum low voltage wire running between the EPO switch and the aGate should not exceed 30 m.
- The EPO shall have a rated voltage of 12 V or higher.

NOTE:



If the external EPO is not connected to the FranklinWH system, please keep the factory default settings (the EPO module is short connected on the EMS module as shown in the figure).



- 1) Make sure all breakers in the aGate and all switches connected to the aGate are disconnected. Wait at least five (5) minutes, and then loosen and remove the one M5 × 12mm screw using a Phillips head screwdriver and remove the inner panel from the aGate. Use a multimeter to check that the AC voltages at both input and output terminals of the aGate are zero (0), to ensure that all electrical equipment has been disconnected from the aGate.

WARNING:

When the EPO button is pressed, the EPO is in the OFF state. That means the EPO function has been activated to protect the system. At this time, aPower will be shut off and all relays inside aGate (including the supply relay, the generator relay, the Smart Circuits relay, and the solar relay) will be disconnected. It also disconnects the utility grid and the backup port on aGate. Auxiliary power remains ON.

Do not use the EPO for maintenance operations or in any condition other than an emergency.

- 2) Remove the short connector on the EPO of the EMS module.

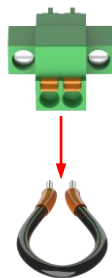

- 3) Connect pins 3 and 4 (labeled EPO) on the EMS to the C (common) and NC (normal close) of the EPO. Use wire 0.5-1.5 mm².



NOTE:

The cable diameter should be between 0.5 mm² and 1.5 mm².

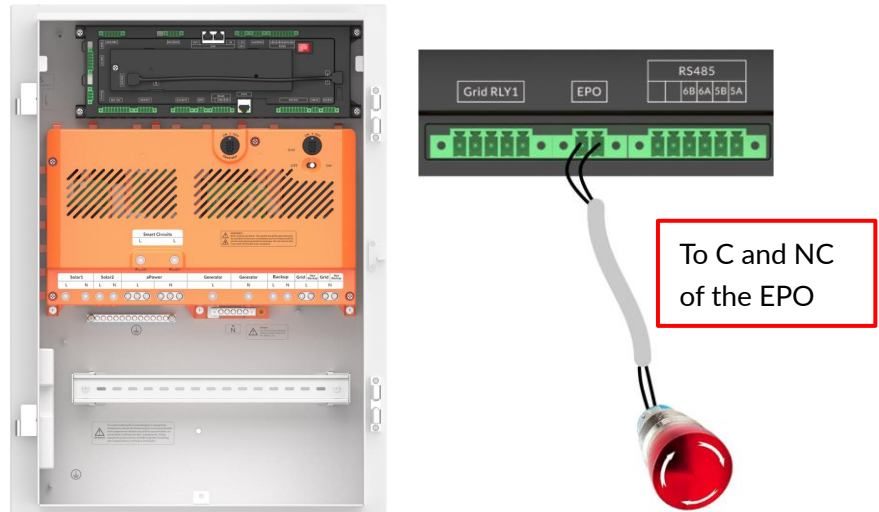

- 4) Install the aGate inner panel and tighten the M5 x 12 screws using a Phillips screwdriver, and then tighten the screws to the recommended torque using a Phillips torque screwdriver.
- 5) Paste “EPO Notice” label.

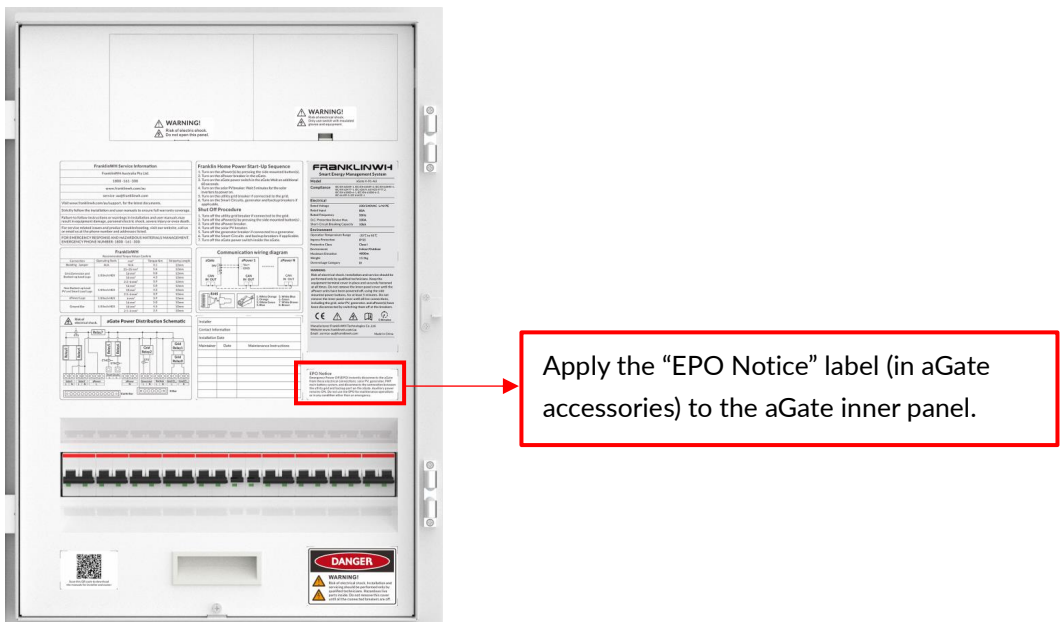

Connecting the Smart Circuits (optional)

aGate has an optional Smart Circuits Module which supports two Smart Circuits, each of which has a separate CT to measure the power usage.

NOTE:



- Refer to the breaker specifications for the tightening torque value for the breaker output cable screws.
 - The ground cable does not pass through the circuit breaker.
-

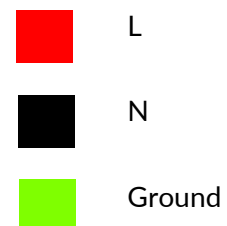
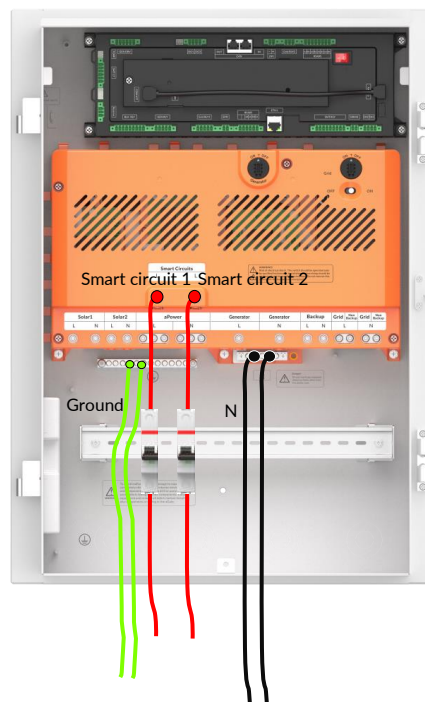

Connecting the Generator (optional)

There are three wiring plans, depending on the type of generator.



NOTE:

If aluminum cables are used, the cable connectors need to be treated using antioxidant.

Type 1: Voltage Sensing



NOTE:

Due to differences in various generator types, the wiring diagram is for reference only. Refer to the specific generator instructions for actual wiring requirements.

- 1) Connect the generator power output wires (L, N, GND) to the generator input terminals on aGate (L, N & GND).
- 2) Remove the original voltage sensing port cable from the generator, connect the R3-J1 cable reserved for the aGate to the J1 port on the R3 board (do not remove the thermoplastic casing on the R3-J1 terminal), and connect the two NC pins of the J2 terminal to the voltage sensing port of the generator through the cable. Select cables ranging from 1 mm² to 2.5 mm² according to local regulations or AS/NZS3000, as shown below.

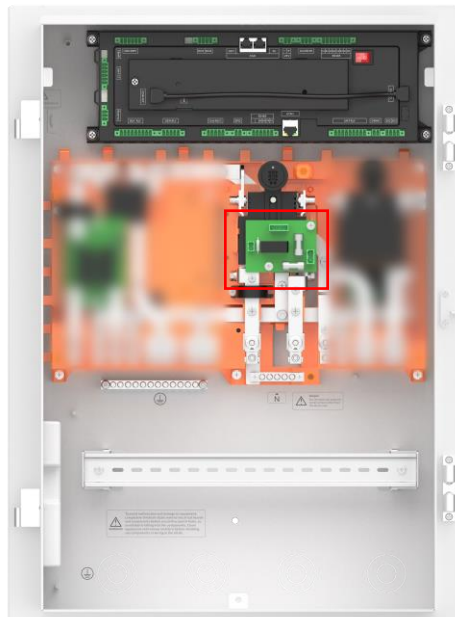

To the voltage sensing port on the generator.

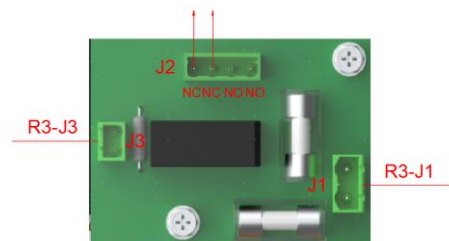

- 3) Make sure to connect the generator's starting battery charge terminal in the generator to the wire from a branch circuit of the Backup Panel.

NOTE:

- A secure connection must be kept between the battery charge terminal and the Backup Panel branch terminal, whether the generator is on or off.
- Do not plug short terminals in the shipping attachment into any interface on the R3 board.

Type 2: ATS

- 1) Remove the power grid input cable from the power grid port on the ATS.
- 2) Connect the grid input cables to the grid terminals (L, N & GND) in aGate.
- 3) Connect the output terminals of the generator system to the generator input terminals on the aGate.
- 4) Connect the R3-J1 cable reserved for aGate to the J1 port on the R3 board (do not remove the thermoplastic casing on the R3-J1 terminal), and connect the two NC pins of the J2 terminal to the mains input port on the ATS through the cable. Select a 1 mm² to 2.5 mm² cable based on the local regulations or AS/NZS3000, as shown below.

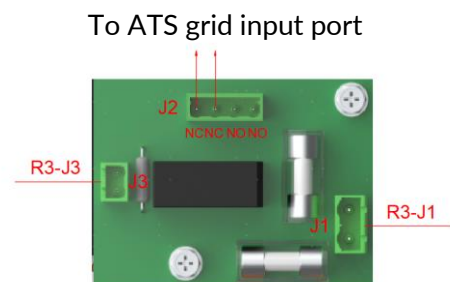
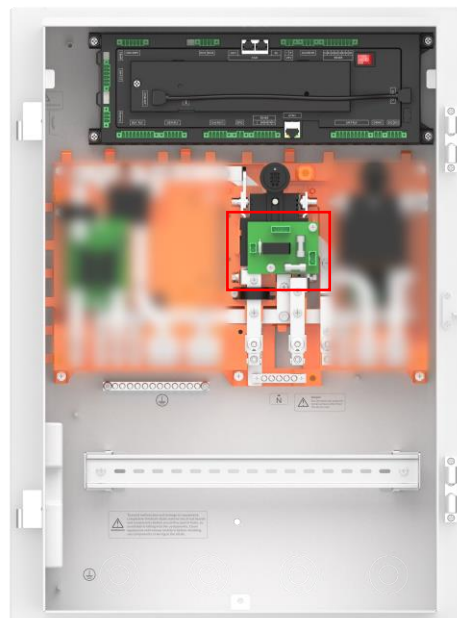
**NOTE:**

- Do not plug short terminals in the shipping attachment into any interface on the R3 board.

Type 3: Dry Contact

- 1) Connect the generator power output wires (L, N, GND) to the aGate generator input terminals (L, N, GND).
- 2) Connect the short terminal in the shipping attachment to the J1 interface on the R3 board, and connect the two NO pins of the J2 terminal to the two-wire starting interface of the generator. Select a cable between 1 mm² and 2.5 mm² according to local regulations or AS/NZS3000, as shown below.

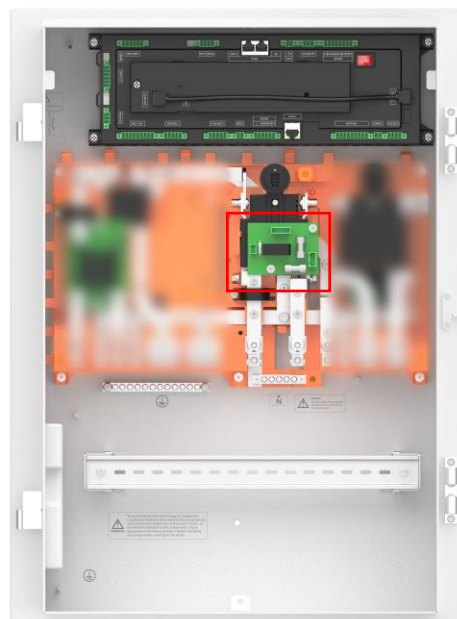

To two wire starting
generator starting port

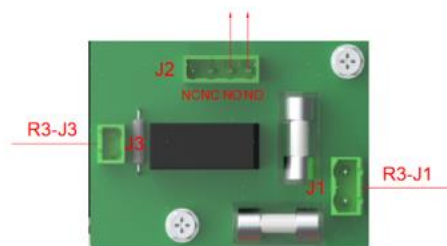

- 3) Connect the generator's starting Battery Charge terminal in the generator to the wire from a branch circuit of Backup Panel.

NOTE:



- The connection must be kept between the Battery Charge terminal and the Backup Panel branch terminal, whether the generator is on or off.
 - Do not insert the R3-J1 terminal reserved for the aGate into any interface on the R3 board.
-

Completing Installation

Re-Install the aPower Wiring Compartment Cover and Install Grilles

① Install the internal cover for the wiring compartment. Please check to make sure the cover label's S/N corresponds with the equipment S/N.

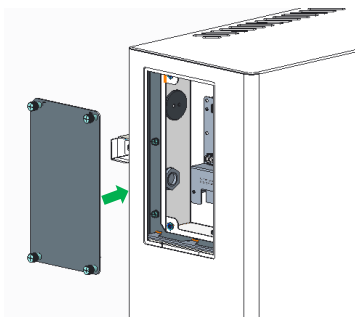

② Tighten the four (4) screws by turning clockwise using a #3 x 100 mm Phillips head screwdriver.

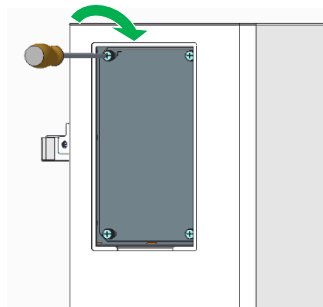

③ Install the external panel.

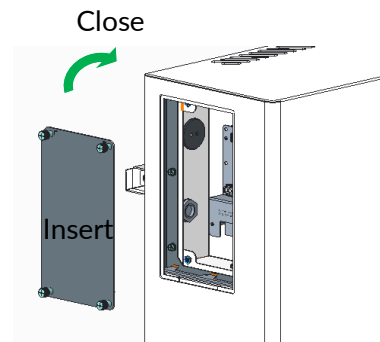

④ Use a diagonal cutting plier to remove the knockout holes on the grille. (According to the installation direction of the conduit adaptor, wiring and **conduit**, remove the knockout holes in the corresponding positions).

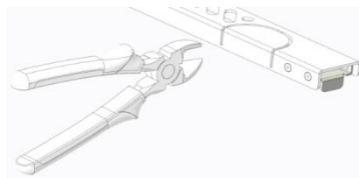

⑤ Install the three grilles.

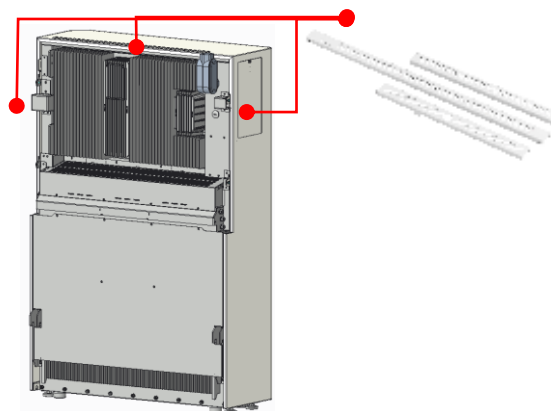

Re-Install the aGate Door and Inner Panel

- Re-fasten the hinges on the aGate door to the aGate cabinet.

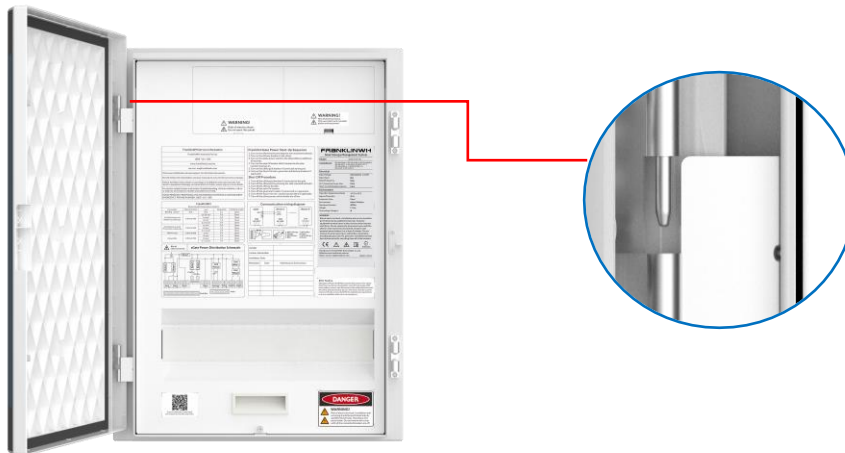

- Install the inner panel and fasten it by tightening the M5 x 12mm bolt.

- After the breakers are installed, place the labels from the literature kit (bag with labels and accessories) on the inner panel of aGate according to the position of the breaker, as shown in the diagram below.

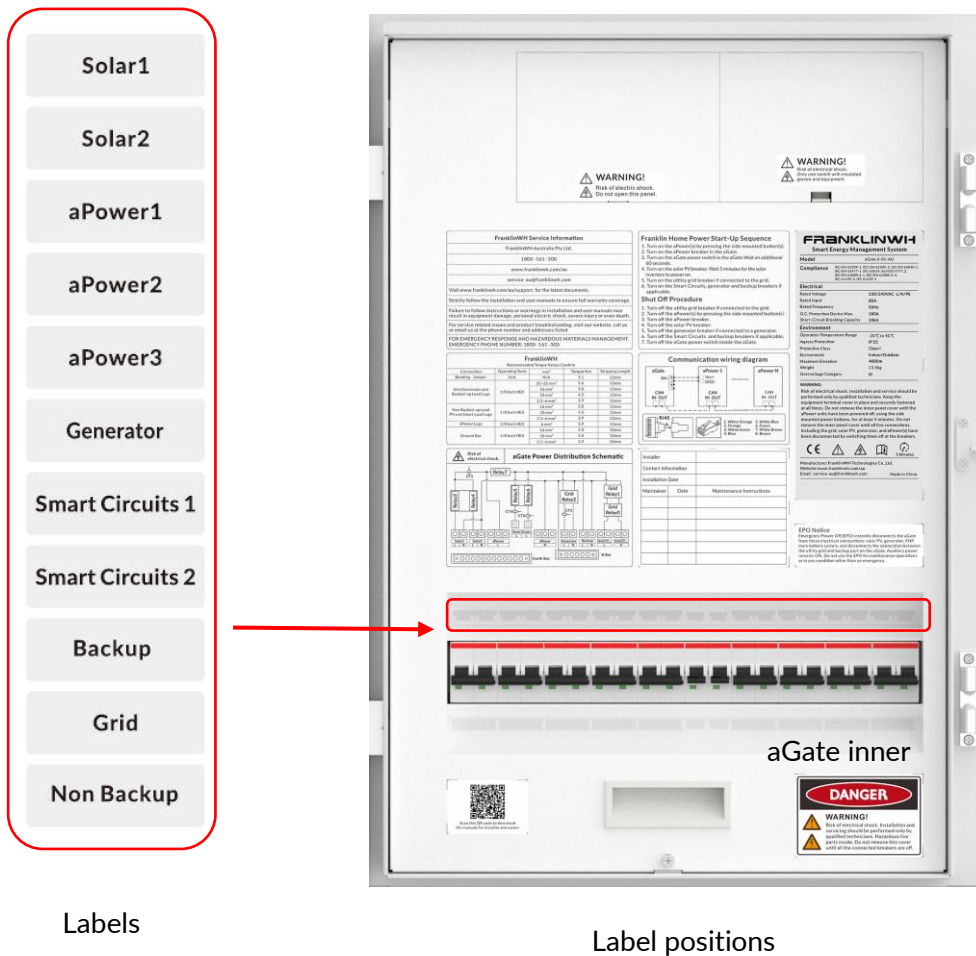

Labels

Label positions

A label Kit with FranklinWH specific labels is available from your distributor.

Appendix 1: Electrical Parameters

Table 1: aGate, aPower

FRANKLINWH AC Coupled BESS	
Model	aGate X-01-AU, aPower X-01-AU, aPower X-02-AU
Compliance	IEC/EN62109-1, IEC/EN62109-2, IEC/EN62040-1, IEC/EN62477-1, IEC62619, AS/NZS4777.2, IEC/EN61000-6-1, IEC/EN61000-6-3
Electrical (aGate X-01-AU)	
AC Input (Grid)	
Rated Voltage	230/240 VAC L/N/PE
Rated Current	80 A
Power Factor Range	-1 leading to 1 lagging
Frequency	50 Hz
AC Input (Generator)	
Rated Voltage	230/240 VAC L/N/PE
Rated Current	80 A
Frequency	50 Hz
Power Factor Range	-1 leading to 1 lagging
AC Input (PV)*2	
Rated Voltage	230/240 VAC L/N/PE
Rated Current (Single or Two)	50 A or 31.5 A
Power Factor Range	-1 leading to 1 lagging
Frequency	50 Hz
Backup Output	
Rated Voltage/Frequency	230/240 VAC L/N/PE
Rated Output Current	80 A
Power Factor Range	-1 leading to 1 lagging
Frequency	50 Hz
Rated Active/Apparent Power (230V)	18.4 kW/18.4 kVA
Rated Active/Apparent Power (240V)	19.2 kW/19.2 kVA
Smart Load*2	
Rated Voltage	230/240 VAC L/N/PE
Rated Current (Single or Two)	50A or 31.5A
Power Factor Range	-1 leading to 1 lagging
Frequency	50 Hz
Rated Active (Single or Two) (230V)	11.5 kW/7.245 kW
Apparent Power (Single or Two) (230V)	11.5 kVA/7.245 kVA
Rated Active (Single or Two) (240V)	12 kW/7.56 kW
Apparent Power (Single or Two) (240V)	12 kVA/7.56 kVA

Non-Backup Output	
Rated Voltage/Frequency	230/240 VAC L/N/PE
Rated Output Current	63 A
Power Factor Range	-1 leading to 1 lagging
Frequency	50 Hz
Rated Active/Apparent Power (230V)	14.49 kW/14.49 kVA
Rated Active/Apparent Power (240V)	15.12 kW/15.12 kVA
Electricity Meter	
Brand	FranklinWH
Model	FBMS8000AJ1
Electrical (aPower X-01-AU & aPower X-02-AU)	
Grid Output	
Coupling	AC Coupled
Rated Voltage	230/240 VAC L/N/PE
Rated Current	21.7 A
Max. Continuous Input/Output Current	24.5 A
Rated Input/Output Power	5 kW
Rated Apparent power	5 kVA
Max. Grid Output Power	5.8 kVA
Power Factor Range	0.8 leading to 0.8 lagging
Max Short Circuit Current/Duration	224 A/40 ms
Battery	
Battery Type	Rechargeable Lithium ion
Battery Voltage Range	42 VDC~58 VDC
Max. Charging and Discharging Current	118 A
Battery Designation	IFpP73/175/206/[1P16S]E/-10+50/95 (aPower X-01-AU) IFpP73/176/208/[1P16S]E/-10+50/95 (aPower X-02-AU)
Battery Rated Voltage	51.2 VDC
Battery Max Short Circuit Current/Duration	550 A/1 ms
Rated Capacity	280 Ah (aPower X-01-AU) 314 Ah (aPower X-02-AU)
Usable Capacity	13.6 kWh (aPower X-01-AU) 15 kWh (aPower X-02-AU)

System parameters	
Operation Temperature Range	-20 °C to 50 °C
Ingress Protection	IP 55 (Minimum) IP 55 (aGate X-01-AU) IP 56 (aPower X-01-AU and aPower X-02-AU)
Protective Class	Class I
Environment	Indoor/Outdoor
Max. Elevation	4000 m
Inverter Topology	None Isolated
Overvoltage Category	AC: III DC: II
Weight - aPower X-01-AU & aPower X-02-AU	185 kg
Weight - aGate X-01-AU	13.5 kg