



FranklinWH System Installation Guide

For Meter Adapter Controller and aPower S

©2026 FranklinWH Energy Storage Inc. All rights reserved.

All information in this Manual is subject to the copyright and other intellectual property rights of FranklinWH Energy Storage Inc. This manual may not be modified, copied or reproduced, in whole or in part, without the prior written permission of FranklinWH Energy Storage Inc.

Please visit [FranklinWH Support](#) for the latest FranklinWH documents.

All brands and trademarks mentioned in this document are the property of their respective owners, and their use in this document does not imply the sponsorship or recognition of their products or services.

Please read this document carefully to ensure the best reliability of the product and your warranty eligibility. For further information about the warranty, please refer to the **FranklinWH Limited Warranty**.

This document is intended for use by professional installation and maintenance service providers only and no statements, information or recommendations in this document constitute any express or implied warranty.



Please read this document carefully before installing or using the FranklinWH equipment. Failure to follow any instructions or warnings in this document may result in damage to the equipment, personal electric shock, severe injury, or even death.

Product Information

The FranklinWH System is composed of multiple hardware and software components.

FranklinWH Energy Storage Inc. (FranklinWH) reserves the right to make any improvements to the product, and the contents in this document shall be subject to updates without further notification.

All images and pictures provided in this Manual are only for demonstration purposes and may differ in detail from the product, based on the product version.

FCC Compliance

This equipment has been tested and found to comply with the limits for a Class B digital device, pursuant to part 15 of the FCC Rules. These limits are designed to provide reasonable protection against harmful interference in a residential installation. This equipment generates, uses and can radiate radio frequency energy and, if not installed and used in accordance with the instructions, may cause harmful interference to radio communications. However, there is no guarantee that interference will not occur in a particular installation. If this equipment does cause harmful interference to radio or television reception, which can be determined by turning the equipment off and on, the user is encouraged to try to correct the interference by one or more of the following measures:

- Reorient or relocate the receiving antenna.
- Increase the separation between the equipment and receiver.
- Connect the equipment into an outlet on a circuit different from that to which the receiver is connected.
- Consult the dealer or an experienced radio/TV technician for help.

MPE caution (if an FCC certified RF module is inserted in and the separation distance is indicated in the FCC grant of RF module).

To satisfy FCC / IC RF exposure requirements, a separation distance of 8 in. (20 cm) or more should be maintained between the antenna of this device and persons during device operation.

To ensure compliance, operations at closer than this distance is not recommended.

Feedback

If you have any questions or comments, please send us an email at: service@franklinwh.com

Disposal of Scrapped Products

Scrapped products (including their internal chemicals and electrical materials) should not be disposed of with household waste. Please refer to your local laws and regulations regarding disposal.



CONTENT







Safety Statements	1
Safety Symbols	1
Safety Instructions for Operation	2
Safety Instructions for Installation Site	5
Fire and Other Emergency Situations	6
Installation Preparations	7
Items Provided by Installers	7
Tools Needed	8
Unboxing the MAC	9
Installation	10
Site Planning	10
MAC Installation	12
Drill Cable Access Hole on the MAC	12
Mount the MAC on a Wall	12
aPower S Installation	13
System Wiring	14
Install Electrical Conduit	14
Communications Wiring	17
Connect the aPower(s) to the Main Panel	23
Install the Current Transformer (CT) (Optional)	27
Install an RSD Switch	29
Install an Optional Emergency Power Off (EPO) Switch	31
Re-install the MAC Cover	33
Commissioning and Acceptance	34
Appendix 1: Datasheet	35
Appendix 2: CT Specifications	36
Appendix 3: Drilling and Fastening for Different Walls	37
Appendix 4: Revision History	38

Safety Statements











This Guide includes important information about the FranklinWH System. Please read this Guide carefully before installation, maintenance, or use. Failure to follow any instruction in this Guide may lead to risks of equipment damage, electric shock, severe personal injury and even death, and may also void the warranty ([FranklinWH Support](#)).













The DANGER, WARNING, and NOTE alerts are supplemental to the safety instructions and are not exhaustive.



Safety Symbols

	DANGER: This indicates a hazardous situation, which if not avoided, could result in serious injury or death.
	DANGER: There are fire risks in the battery packs.
	WARNING: This indicates a situation where failure to follow instructions may be a safety hazard or cause equipment malfunction. Use extreme caution and follow instructions.
	NOTE: This indicates information important for optimal system operation. Follow instructions.
	PROTECTIVE GROUNDING TERMINAL: This indicates the position of grounding connection on the equipment.
 5 Minutes	WAIT TIME: It means there are electric shock risks inside the equipment, please wait 5 minutes before proceeding.
	ELECTRONIC DEVICE: DO NOT THROW AWAY. Scrapped electronic products and batteries cannot be disposed of together with household wastes. Please consult your local laws and regulations for further information.













Safety Instructions for Operation

	DANGER: The installation, wiring, maintenance, transportation, and handling of each MAC and aPower should follow local laws, regulations and standards, and the Safety Instructions in this Guide serve as supplementation to the laws, regulations, and standards.
	DANGER: Before any electrical operation starts, please turn off the grid power supply switch, generator input switch, the PV input switch, the load switch, and lock the switches. If the switches cannot be locked, please lock the distribution box where the switches are installed. A warning sign, Out of Operation , or Do NOT Turn On , should be hung.
	DANGER: Both aPower and MAC are electrical equipment, and improper operation may lead to electric shock, energy hazards, or chemical hazards. Do NOT open the cabinet or disassemble without express direction from the FranklinWH service team.
	DANGER: Only FranklinWH Certified Installers and other qualified technicians may install, maintain, or replace MAC and aPower equipment or wiring. They must wear personal protective equipment (PPE) during operation.
	DANGER: It is strictly forbidden to work on or operate the system alone. For safety, make sure that there is someone around you who can help.
	DANGER: It is strictly forbidden to install, maintain, or handle the system outdoors during bad weather conditions, such as lightning, thunder, rain, snow, or strong winds.
	DANGER: In case of a battery fire, please take action as instructed in the <i>Safety Data Sheet</i> .
	DANGER: The aPower must be carefully handled and installed using lifting equipment to avoid injury to installers or the aPower.
	DANGER: During the transport and handling of MAC and aPower units, extreme care is required to avoid dropping, bumping, stomping, or inverting the equipment. To prevent potential damage, please keep all units in their packaging until ready to install.
	DANGER: During use, storage, and transport, ensure that the ambient temperature of an aPower does not exceed 122° F (50° C), that it is not near flammable items, and that the cooling system and vents are not blocked.
	DANGER: Do not attempt to take apart, repair or modify a MAC or aPower without the authorization from FranklinWH. And it is prohibited to open the battery pack chamber in any situation. Otherwise, it may lead to safety hazards and void your warranty.

	DANGER: To prevent misoperation, ensure that the upstream and downstream switches are disconnected and padlocked during installation or maintenance.
	DANGER: If a MAC or aPower is found damaged (except for minor defects in exterior painting) after it is unboxed or malfunctioning on installation, please do NOT operate it. Contact your after-sales service provider for support.
	DANGER: Before any installation and commissioning of an aPower, please keep the round button on the right of aPower off (extended, flush with the case) and prevent the ON/OFF switch from being operated by mistake.
	DANGER: If the aPower battery is leaking electrolyte, smoking, or catching fire, if it is safe to do so, disconnect the AC power from the FranklinWH System, and turn off the aPower switch to stop charging and discharging the battery.
	DANGER: The installation of the FranklinWH System must comply with all applicable codes and requirements set by the local AHJ and/or the state.
	DANGER: Both electric connection and electric isolation need to comply with the local standards and National Electric Codes (NEC), ANSI/NFPA 70 or Canadian Standards Association CSA C22.1.
	DANGER: The installer needs to provide suitable conduits and cables and complete the installation process in accordance with the local regulations and UL 514B.
	WARNING: For maintenance purposes, do NOT use any parts or fittings that are not listed in this Guide or that are purchased from any source other than FranklinWH or its recognized dealers.
	WARNING: Measures should be taken to prevent foreign objects from entering any aPower or MAC.
	WARNING: Do NOT use paint on any part of a MAC or aPower, whether internal or external, especially on the protective cover except for exterior paint that has been worn out or damaged in the transportation, installation, or maintenance process. The damaged part can be repaired with paint or topcoat of the same color.
	WARNING: Do NOT connect an aPower directly to the PV inverter.
	WARNING: Before installation, do not store an aPower on site for more than one month. After installation, do not turn on the aPower before connecting the PV and grid, otherwise the battery will be depleted due to a long period of time without charging.

	WARNING: This FranklinWH System is composed of one MAC, one or more aPower battery units, and other electrical components which may be used separately.
	WARNING: An aPower may only be connected to the aPower breaker on the main panel.
	WARNING: The operation of the FranklinWH System requires an Internet connection. Extended offline operation may result in a voided warranty. Please refer to FranklinWH Support for information.

Safety Instructions for Installation Site

	DANGER: The installation site of aPower and MAC units should be away from heating devices, or any source of heat and/or fire.
	DANGER: The aPower and MAC installation area should be well-ventilated to maintain the ambient temperature within -4° F to 122° F (-20° C to 50° C) and the relative humidity between 5% and 95%.
	DANGER: The aPower and MAC installation area shall not be located in areas subject to flooding or standing water. The aPower battery and integrated inverter are rated IP67, while the wiring compartment is rated IP56.
	DANGER: The aPower and MAC installation area should be away from flammable and explosive materials.
	DANGER: The installation site for the FranklinWH System must meet all applicable codes and standards.
	WARNING: Before the installation starts, engineers should check and locate the embedded electric wires and water pipes to avoid potential property damage and personal injury during the installation process.
	WARNING: aPower units may be installed on the floor or on wall; floor installation is recommended. If wall-mounted, the wall should be able to provide sufficient bearing capacity.
	WARNING: The aPower and MAC installation site should have no water sources above it or in the vicinity, including water pipes, shower, faucet, and containers of liquids.
	WARNING: The installation site should be properly leveled and hardened if the aPower is floor mounted. If there is grass nearby, a layer of cement or slab stone must be placed on the projection area around the equipment to prevent grass growth and protect the equipment.
	WARNING: Do NOT clean aPower and MAC units with cleaning agents or expose them to flammable or irritant chemicals or their vapors.
	WARNING: It is required that either Ethernet or Wifi connectivity is provided at the MAC installation site. Ethernet and Wifi connections are more reliable, but 4G connection are also possible, though not suggested, as the primary method.
	RECOMMENDATION: It is recommended to avoid a direct south-facing orientation when installing outdoors for optimal performance.

Fire and Other Emergency Situations

Fire:

- Shut off the aPower breakers on the main panel, if it is safe to do so.
- When the main panel is locked, if safe to do so, the user can manually press the EPO button on the MAC unit to power down the entire system.
- Evacuate to a safe area.
- Contact 911 as soon as it is safe to do so.
- Use approved fire extinguishing devices, if it is safe to do so.

Flood:

- Shut off the aPower breakers on the main panel if it is safe to do so.
- When the main panel is locked, if safe to do so, the user can manually press the EPO button to power down the entire system.
- If the wiring sections of an aPower, MAC, or MSA are submerged, stay away from the water. Electric leakage may result in electric shock.
- Drain the water to protect the system if it is safe and possible.
- If water rises to the battery level, please call your installer for inspection. If the water level is below the battery chamber, please allow the site to completely dry.

Abnormal noise, odor, or smoke:

- Shut off the aPower breakers on the main panel, if it is safe to do so.
- When the main panel is locked, if safe to do so, the user can manually press the EPO button to power down the entire system.
- Check and ensure your aPower is well ventilated and the vents are not blocked.
- Keep the installation site well ventilated.
- Call your after-sales service for support.

Installation Preparations

Items Provided by Installers



1	Electrical conduit, conduit hub, pull box and fittings
2	Screws and M6/M8 big spacers for wall installation
3	aPower combiner box (for parallel operation of multiple aPower units)
4	5/8 in. Type X plasterboard
5	Copper or aluminum cables
6	Circuit breakers. For details, refer to the Connect aPower to the Main Panel section for circuit breaker models
7	Reducing washer conduit fittings
8	Network cable and registered jacks
9	Antioxidant conductive paste
10	Sealant (for use on outdoor conduits)
11	Hoses and hose fittings

Tools Needed

- Torque wrench and bent-handle ratchet wrench, with 11/32", 5/16", 13/32", 7/16", and 3/8" hex sockets, to tighten and check the torque of outer hexagonal bolts.
 - 3/16" inner hexagon screwdriver bits to fasten cables at circuit breakers and pressure connectors and to check the torque.
 - 1/4" straight screwdriver bits to fasten cables at circuit breakers and connectors and to check the torque.
 - PH2, PH3 Phillips screwdriver bits to fasten cables at circuit breakers and to check the torque.
 - 6" Phillips head extension.
 - 4" extension rod.
- 2 mm flat screwdriver for CTS connectors
- Electric screwdriver and cross screw bits to tighten the fastening screws.
- Phillips torque screwdriver.
- Steel measuring tape to measure lengths.
- Markers to make drilling marks.
- Camera to record the installation process.
- Deep cut band saw to cut thin-wall steel conduit or PVC pipes.
- Knockout Tool Kit to drill holes.
- Adjustable wrench, size: 0-1.97 in. (0-50 mm).
- 6", 10", 18" Pipe Wrenches.
- Lockout Tagout.
- Insulated Tape.
- Multimeter.
- 1/4" Open End Interchangeable Torque Wrench.

NOTE



It is best to use battery-powered portable tools, as there may be no power supply at the construction site, and the power switch will need to be turned off.

Torque Requirements

Screw type	Cross head screwdriver	Tightening torque
M4	PH2	1.03 lb-ft (1.4 N·m)

Unboxing the MAC

- 1) Inspect the package for damage, scratches or dents.

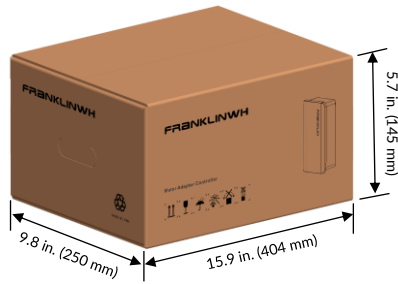

- 2) Adjust the utility knife blade to less than 0.3 in. (7.62 mm) as it may damage the MAC if too long. Cut the adhesive tape on the upper surface of the box.
- 3) Open the box, take out the accessories, and then take the MAC out of the box.
- 4) Check that you have the following:



1	2	3
MAC cover	MAC chassis	1/4" water-tight Washers, x3
4	5	6
EQB MSA communications cable	Cable ties, x2 (optional use)	Cable tie mount, x1 (optional use)

Installation



DANGER

Care must be taken to protect personal safety. Reinforced toe shoes must be used to protect the installers in case equipment tilts or falls.



Site Planning

1. Plan installation position

NOTE



- The installation location must avoid water and power conduits. Refer to all applicable local codes and standards.
- The clearance details below are general guidelines for spacing in accordance with NEC requirements. For countries or regions where NEC requirements are not applicable, please consult with your AHJ or Utility before finalizing the spacing.
- It is best practice to install the MAC and aPower in an area protected from direct sunlight, rain and snow. Extreme heat from direct sunlight may derate the output or affect equipment longevity beyond the warranty period for MAC and aPower.

- a) Choose a mounting location that can bear the weight of the MAC and aPower.

When installing a MAC with an EQB MSA, the distance from the MSA should not exceed 72 in. (1.83 m).

When installing a MAC with a ConnectDER MSA, choose the installation location based on the ConnectDER communications cable length.

To ensure stable wireless signal transmission (Wifi, Bluetooth) for the MAC and to prevent interference and shielding by metal materials, the vertical distance between the top of the MAC and any metal objects (such as metal cabinets, brackets, decorative panels, etc.) should be no less than 2 in. (0.05 m).

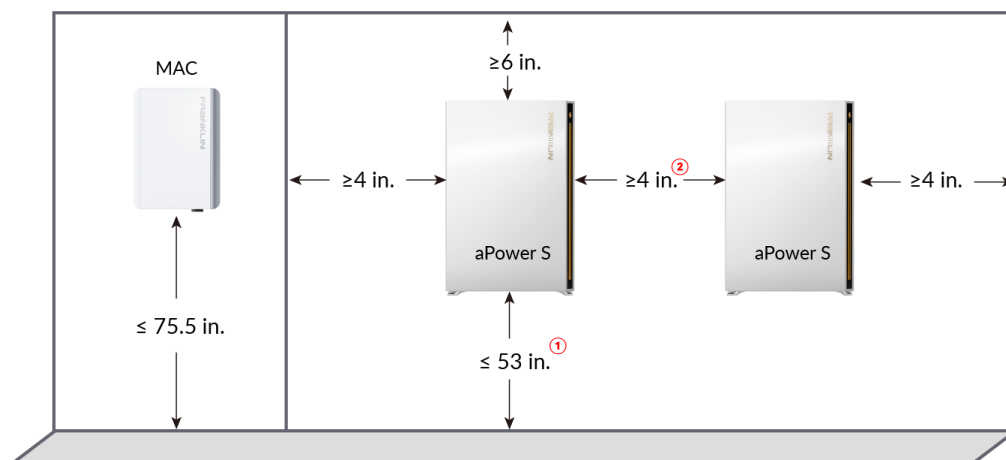

① NEC 408.4(A) requires the power switch to be no more than 79 in. (2 m) from the ground.

② 4 in. (0.1 m) between adjacent aPower units is UL9540A required clearance. FranklinWH suggests a clearance of 14 inches for optimal operation of the electric drills and screwdrivers during installation.

Allow sufficient space for proper conduit routing. The maximum distance between the bottom of the MAC and the ground shall be 75.5 in. (1.92 m). No other installation requirements are mandatory, offering flexibility depending on the situation.

- b) The system requires an internet connection. All signal transfers between the aPower, MAC, and router are provided by a CAN bus, network cables, or other signal transmission cables. Long distances will likely adversely affect the quality and speed of communications, negatively impacting equipment operations. Recommended maximum cable lengths listed below.

Connection	Maximum cable length
aPower to MAC	164 ft (50 m)

2. Plan the types, sizes and routes of cable and electrical conduits

- a) As cables run through the electrical conduits:
- The current carrying capacity of the cables needs to be reduced. Please refer to the applicable information in Appendix B of NFPA 70.
 - The relationship between wire diameters, cable numbers, and inner diameters of conduits should be taken into consideration. Please refer to Appendix C of NFPA 70 for the list of maximum numbers of cables of the same size in the electrical conduits and pipelines.
- b) The type of electrical conduits depends on the installation type, indoor or outdoor:
- IMC, EMT and other thin-wall metal conduits are recommended for indoor installations. These two types of conduits are cost effective, provide excellent anti-electromagnetic interference, and are easy to shape and to joint.
 - In outdoor installations, GRC and RMC thick-wall conduits are recommended because they can provide effective mechanical protection and good tightness at the conduit joints. Thick-wall conduits have a reduced flexibility disadvantage which makes bending and jointing very difficult.

3. Fire Code Compliance

The installation must comply with all applicable local codes, relevant regulations, and the requirements of local fire authorities.

4. FCC Requirements

See preface for the applicable FCC Requirements. The installer should inform customers of the contents in Appendix.

MAC Installation



DANGER: Avoid drilling holes in water pipes and cables in the wall.



WARNING: No side conduit entry.



NOTE: During the installation process, keep the MAC well protected from hard objects that may scratch the surface and body.

Drill Cable Access Hole on the MAC

The cable knockout on the bottom right of the MAC enclosure is 1-1/4", in diameter. Drill the required cable access hole in the enclosure as required for the site. Apply waterproofing as needed to prevent moisture ingress.

Note: Do not leave excess cable inside the MAC. The total cable length routed inside shall not exceed 8 in. (20 cm).



Mount the MAC on a Wall

Follow the procedures below to install the MAC on a wall.

- 1) Place the MAC at the planned installation position. Adjust the MAC to level and then make marks at the three holes.
- 2) Store the MAC in a safe place where it will avoid dust from drilling. Using an appropriate drill bit to drill holes in the wall.
- 3) Once drilling is complete, mount the MAC enclosure vertically on the wall. The water-tight washers provided must be used when mounting the MAC.

See [Appendix 3: Drilling and Fastening for Different Walls](#) for more details on the hole depth and type of fasteners to use corresponding to different type of wall.

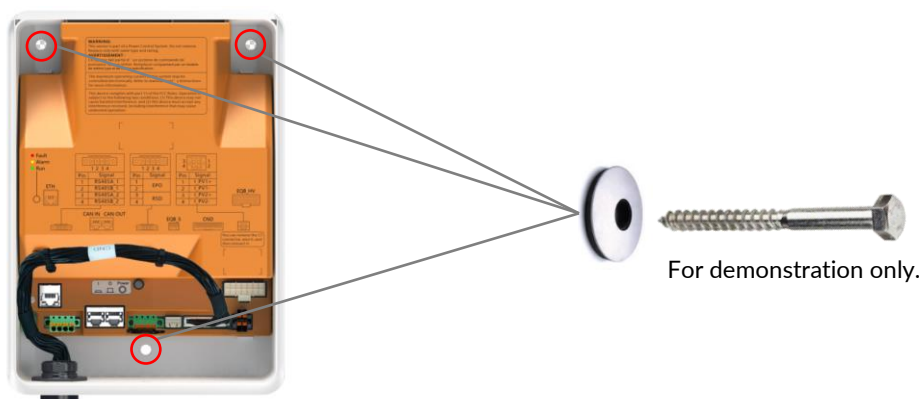

aPower S Installation

Refer to *FranklinWH System Installation Guide* for guidance on installing the aPower S.

WARNING: The aPower S can only be connected to the EQB 100 A tap if the following conditions are met; otherwise, it will void the warranty:



- The EQB device has a prominent safety label: Turn off and disconnect aPower connected to the 100 A tap when performing maintenance or repair.
 - The aPower N line is connected to the Main Panel.
-



WARNING: If an older, non-IEEE 1547-compliant PV inverter is AC-coupled to the aPower S with the MAC, an aHub is required.

System Wiring

Install Electrical Conduit



WARNING: The conduits and related materials must comply with UL 746B requirements as well as all local laws and regulations.

Metallic conduits and fittings are recommended to minimize electromagnetic interference.

The following are conduit connection and installation instructions for different cable entry scenarios.

The image below shows an example of conduit and fitting for different applications.

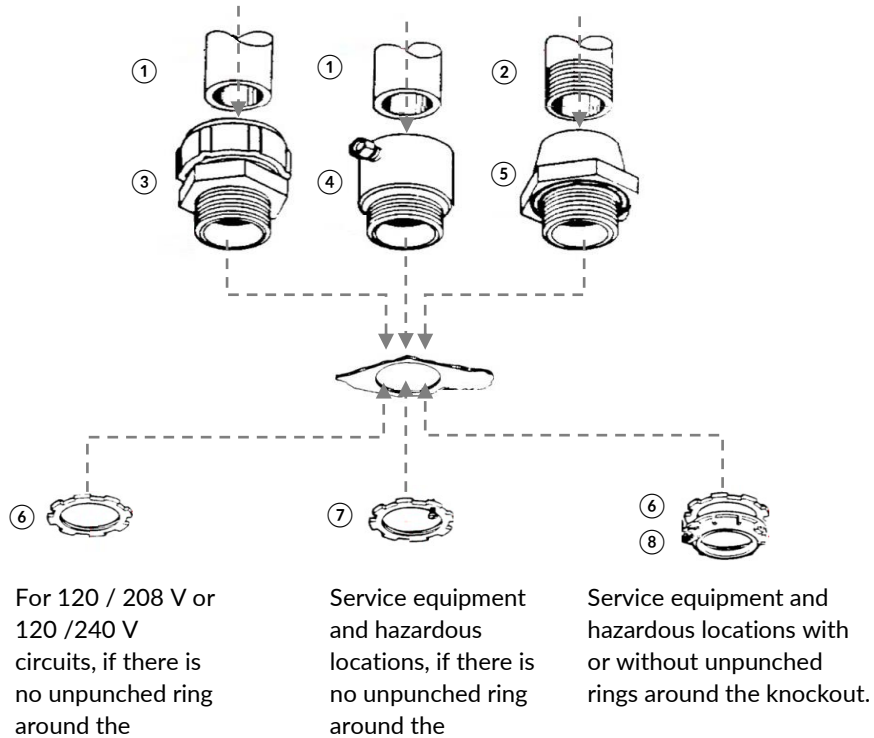

No.	Description
1	Threadless rigid metal conduit or intermediate metal conduit
2	Threaded rigid metal conduit or intermediate metal conduit
3	Threadless fitting
4	Screw fitting
5	Sealing hub
6	Locknut
7	Bonding knockout
8	Bonding & grounding bushing

Install a non-metallic electrical conduit at the bottom of the MAC

When using a MAC with a ConnectDER MSA, install the conduit and hose fittings directly onto the pre-drilled holes at the bottom of the MAC.

When using a MAC with an EQB MSA, use the following steps to connect the two devices.

- 1) Pass the end of the EQB MSA communications cable, which has two connectors, through the 1-1/4" [pre-drilled hole](#) at the bottom of the MAC and connect it to the **EQB_S** and **EQB_HV** ports.

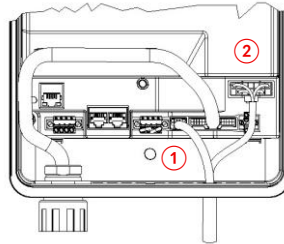

- 2) Pass the three connectors on the other end of the EQB MSA communications cable through the hose fitting and electrical conduit. Depending on site conditions, choose either a straight or angled 1-1/4" hose fitting to ensure a secure connection. The diagram below shows the straight fitting connection.

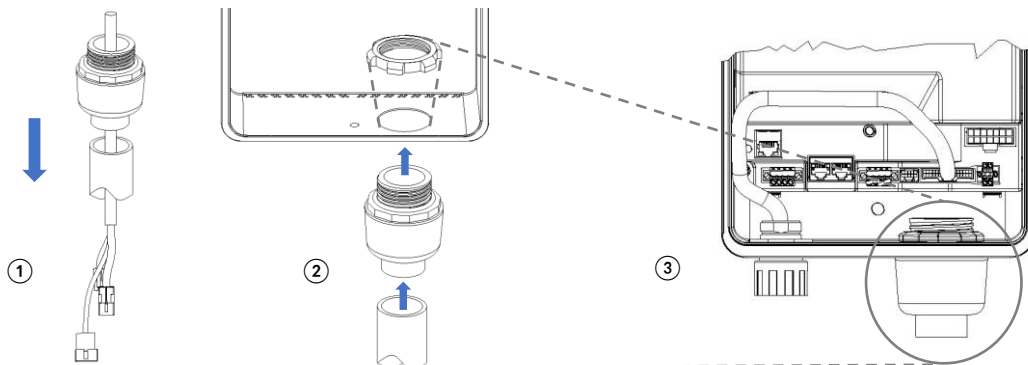

For demonstration only.

- 3) Take the cable tie mount out of the accessories package, peel off the liner to reveal the adhesive surface.

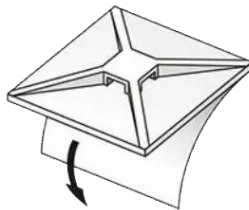

- 4) Align the cable tie mount with the designated installation position inside the MAC. Gently press it to ensure full contact with the bonding surface.
- 5) Insert a cable tie through the slot on the mount and position the MSA communications cable along the intended path, as shown in the diagram below. Once the harness is properly arranged, tighten the cable tie around it to secure the cables in place, preventing any tangling or movement.

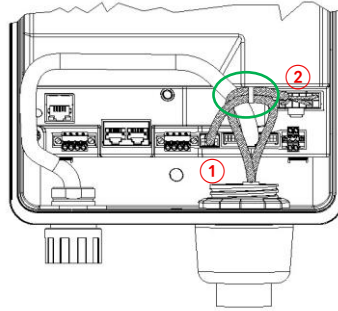

Communications Wiring

Establish communications between the FranklinWH App and the MAC

- 1) Connect the mobile device to the MAC hotspot or Bluetooth to establish a local communications connection between the FranklinWH App and the MAC.

The default connection method is to scan the equipment QR code to connect to the MAC hotspot. Alternatively, you can tap **Manually Connect** to jump to the phone's Wifi settings interface, select the MAC hotspot network, which is named with AP and the last nine digits of SN (e.g., AP_F23050182), and connect the app.

If the MAC hotspot is not available, you may search near the MAC for Bluetooth connectivity. Select the MAC Bluetooth connection named with the system and the last six digits of the MAC SN (e.g., FHP_456789), then connect to the MAC with Bluetooth pairing.



NOTE: Users may remotely modify the password with the FranklinWH App.

- 2) Connect the MAC to the home internet network for remote access.
 - a) **Method 1 (Recommended): Connect the MAC to the home internet using an Ethernet communications cable (Not provided).**

To ensure the reliability of remote communications, it is recommended to connect the home network cable with internet connection to the **ETH** port on the MAC.

Network Cable Installation with Conduit

Route the network cable through the conduit and connect it to the **ETH** port on the MAC.

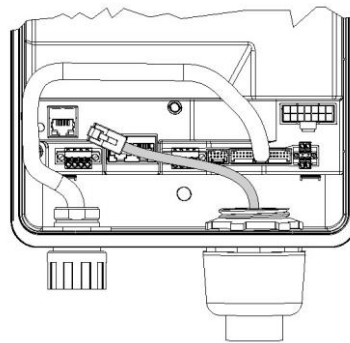

WARNING

The cable from the home network may only be connected to the **ETH** port.



The communications cable needs to be made on site using a crimping tool, a ready-made network cable should not be used because it may prevent the MAC internal cover from closing. Test with a network cable tester to ensure that the cable contact is error-free. The network cable used needs to meet UV protection requirements.

Communications cable preparation

- i. Remove the insulation jacket from the cable.
- ii. Fan the wires in the order of 568B (See wiring scheme diagram).
- iii. Insert the wires into the connector.
- iv. Crimp the connector using a crimping tool and then the cable is ready.
- v. Test with a network cable tester to ensure that the communications cable contact is error-free. Before testing the cable, ensure that both ends of the cable are disconnected from the FranklinWH System.



Wiring scheme

The communications cable wiring must conform to the 568B standard sequence.

- Pin 1: white/orange
- Pin 2: solid orange
- Pin 3: white/green
- Pin 4: solid blue
- Pin 5: white/blue
- Pin 6: solid green
- Pin 7: white/brown
- Pin 8: solid brown

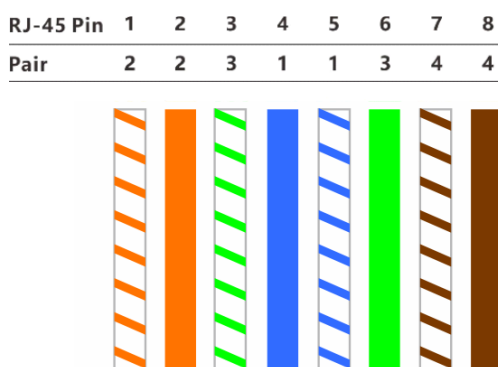

b) Method 2: Connect via Wifi

The Wifi connection between the MAC and home wireless network should be done during commissioning. Please refer to the *FranklinWH Commissioning Guide*.



c) Method 3: Connect via 4G network (only as backup)

A SIM card is pre-installed on the wireless module. When you choose 4G network connection, make sure that there is a good 4G LTE signal in the local area.

Establish communications between the MAC and the MSA

The MAC is compatible with an MSA from either EQB or ConnectDER. For MSA installation procedures, please refer to the EQB manufacturer's installation manual or ConnectDER manufacturer's installation manual.

WARNING: Do not plug in or disconnect the EQB or ConnectDER device while the MAC is powered on (i.e., no **hot-plugging**). Hot-plug operations may cause signal interference, **voltage transients (including power surges or undervoltage events)**, which could trigger false system alarms and potentially disrupt normal household power usage.



If you need to connect or disconnect the EQB/ConnectDER, please follow the steps below:

1. Completely power off the MAC first (turn off the power switch or disconnect the power supply), and then perform the plug-in or removal of the EQB/ConnectDER.
2. After confirming that the MSA communications cable connection is secure and properly seated, restore power and restart the MAC.

Connect to an EQB MSA

- 1) Drill a 1-1/4" hole on the left side of the MSA unit enclosure.
- 2) Pass the three connectors on the other end of the MSA communications cable, which is connected to the MAC, through the hose fitting and install the fitting onto the hole on the MSA.
- 3) Route the three connectors through the 1-1/4" drilled hole in the MSA and the locknut. Then, secure the locknut to the hose fitting.
- 4) Insert the three connectors from the communications cable into their corresponding connectors inside the MSA.

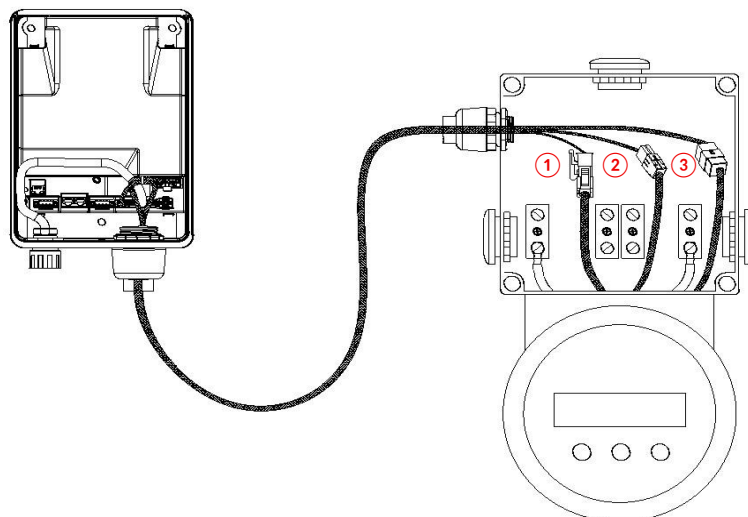

Connect to a ConnectDER MSA

- 1) Unplug the sealing cap.
- 2) Align the connector on the other end of the ConnectDER communications cable with the key slot in the socket on the MAC's bottom.
- 3) Insert the aviation plug and rotate it clockwise until a click is heard.

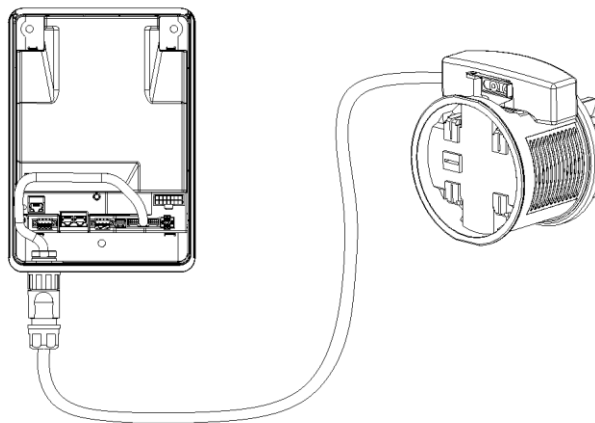
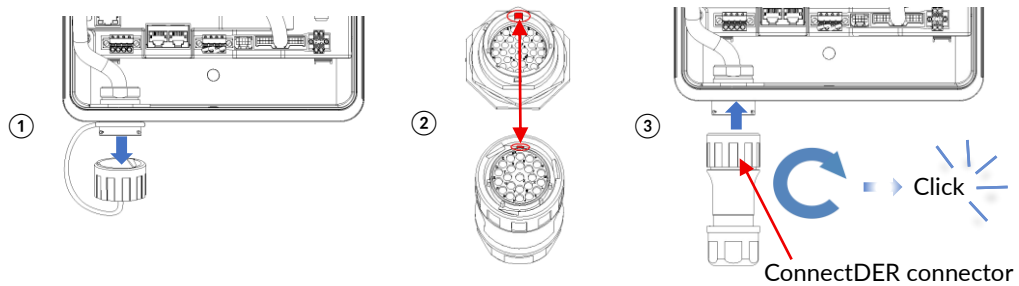

Note: Maintain a safe cable bending radius to avoid damage to the cable structure or performance.

Establish communications between the MAC and the aPower



NOTE: It is recommended to install the communications cable in a conduit to avoid accidental damage and equipment failure. If the network cable and the power cable share the same conduit, use a shielded network cable (RJ45 cable end with metal connector).

Before connecting the communications cable, use a network cable tester to ensure that the cable contact is error-free.

The distance between the MAC and the first/single aPower must be ≤ 164 ft (50 m).

Communications connection between the MAC and a single aPower

Remove the dust plug from the aPower CAN port.

Use a minimum CAT5 cable to connect the MAC **CAN OUT** port to one of the aPower **CAN** ports.

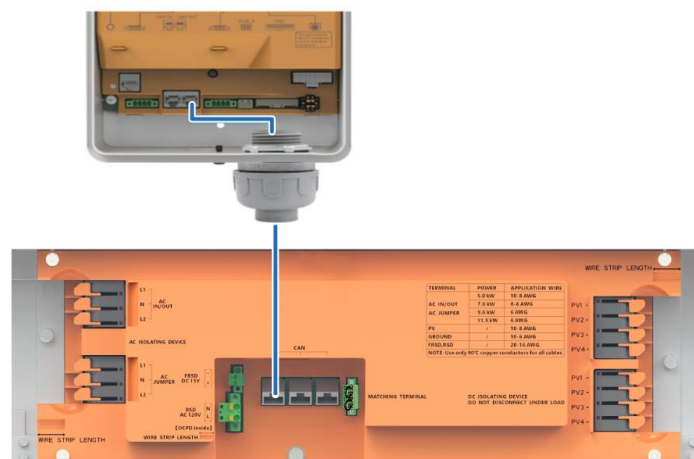

Communications connection between the MAC and two aPowers

Remove the dust plugs from the aPower CAN ports.

Use a minimum CAT5 network cable to connect the MAC **CAN OUT** port to one of the **CAN** ports of the first aPower. Connect the **CAN** ports on the remaining aPower units in sequence.

Remove the matching terminal jumper from the first aPower, and keep the matching terminal jumper on the last aPower.

The image consists of three vertically stacked panels illustrating the CAN bus connection. The top panel shows a MAC unit with a blue line indicating a connection from its 'CAN OUT' port to the 'CAN' port of the first aPower unit. The middle panel shows the first aPower unit's 'CAN' port connected to the 'CAN' port of the second aPower unit. The bottom panel shows the second aPower unit's 'CAN' port connected to the 'CAN' port of the third aPower unit. The aPower units are orange and feature a terminal block with various ports labeled 'CAN', 'CAN+', and 'CAN-'. A terminal jumper is shown being removed from the first aPower and kept on the last aPower.

NOTE

The three CAN ports in the aPower S are interchangeable. Use any port as needed.

If the distance between the MAC and the first/single aPower exceeds 164 ft (50 m), please contact engineering@franklinwh.com for guidance.

22

Connect the aPower(s) to the Main Panel

NOTE



- Use ONLY copper conductors with a temperature rating of 194° F (90° C) for aPower connections.
- The hold down kit is used to mechanically secure aPower breakers onto the main panel. The breaker hold-down kit may be required by the local authority having jurisdiction.

aPower Breakers Options

Select the appropriate aPower breaker and wire gauge based on the desired power output.

Nominal Output Power (AC)	Maximum Apparent Power	Maximum Continuous Current	Recommended minimum wire gauge
5.0 kW	5.0 kVA	21 A	10 AWG
7.6 kW	7.6 kVA	32 A	8 AWG
9.6 kW	9.6 kVA	40 A	6 AWG
10 kW/11.5 kW	11.5 kVA	48 A	6 AWG

NOTE: In both on-grid and off-grid modes, the aPower S output is set to the PCS permanent derate value configured during system commissioning. The PCS derate feature applies to both charging and discharging rates.

If the homeowner plans to add backup loads later, it is recommended to use 6 AWG wire gauge to avoid the need for upgrades. A smaller wire gauge may overheat, posing safety risks.

The nominal output power of aPower S shall be as specified on the product nameplate.

Table 1 aPower Breakers

aPower Breaker				
S/N	Description	Manufacturer Model 1	Manufacturer Model 2	Manufacturer Model 3
1	2-Pole, 10 kAIC, 30 A/240 V	Eaton #BR230	Siemens #Q230	Schneider #HOM230
2	2-Pole, 10 kAIC, 40 A/240 V	Eaton #BR240	Siemens #Q240	Schneider #HOM240
3	2-Pole, 10 kAIC, 50 A/240 V	Eaton #BR250	Siemens #Q250	Schneider #HOM250
4	2-Pole, 10 kAIC, 60 A/240 V	Eaton #BR260	Siemens #Q260	Schneider #HOM260
5	2-Pole, 10 kAIC, 70 A/240 V	Eaton #BR270	Siemens #Q270	Schneider #HOM270
6	2-Pole, 10 kAIC, 80 A/240 V	Eaton #BR280	Siemens #Q280	Schneider #HOM280
7	2-Pole, 10 kAIC, 90 A/240 V	Eaton #BR290	Siemens #Q290	Schneider #HOM290
8	2-Pole, 10 kAIC, 100 A/240 V	Eaton #BR2100	Siemens #Q2100	Schneider #HOM2100
9	2-Pole, 22 kAIC, 30 A/240 V	Eaton #BRH230	Siemens #Q230H	N/A
10	2-Pole, 22 kAIC, 40 A/240 V	Eaton #BRH240	Siemens #Q240H	N/A
11	2-Pole, 22 kAIC, 50 A/240 V	Eaton #BRH250	Siemens #Q250H	N/A
12	2-Pole, 22 kAIC, 60 A/240 V	Eaton #BRH260	Siemens #Q260H	N/A
13	2-Pole, 22 kAIC, 70 A/240 V	Eaton #BRH270	Siemens #Q270H	N/A
14	2-Pole, 22 kAIC, 80 A/240 V	Eaton #BRH280	Siemens #Q280H	N/A
15	2-Pole, 22 kAIC, 90 A/240 V	Eaton #BRH290	Siemens #Q290H	N/A
16	2-Pole, 22 kAIC, 100 A/240 V	Eaton #BRH2100	Siemens #Q2100H	N/A
17	2-Pole, 10 kAIC, 125 A / 240 V	Eaton #BR2125	Siemens #Q2125	Schneider #HOM2125
18	2-Pole, 22 kAIC, 125 A / 240 V	Eaton #BRH2125	Siemens #Q2125H	N/A
19	2-Pole, 10 kAIC, 2X30 A/240 V	Eaton #BQC230230	Siemens #Q23030CT2	Schneider #HOMT230230
20	2-Pole, 10 kAIC, 2X40 A/240 V	Eaton #BQC240240	Siemens #Q24040CT2	N/A
21	2-Pole, 10 kAIC, 2X50 A/240 V	Eaton #BQC250250	N/A	N/A

22	2-Pole, 10 kAIC, 2X30 A/240 V	Eaton #BQ230230	N/A	N/A
23	2-Pole, 10 kAIC, 2X40 A/240 V	Eaton #BQ240240	N/A	N/A
24	2-Pole, 10 kAIC, 2X50 A/240 V	Eaton #BQ250250	N/A	N/A

Single aPower Wiring

Follow these guidelines when wiring one aPower to the main panel:

- Use one (1) pair of wires for a single aPower connection to the aPower 2-pole breaker on the main panel.
- The recommended strip length for the cable connected to the AC terminal of the aPower is 0.73 to 0.76 in. (18.5 to 19.3 mm).
- To connect the other end of the cable to the main panel breaker, determine the cable stripping length based on the breaker configured.

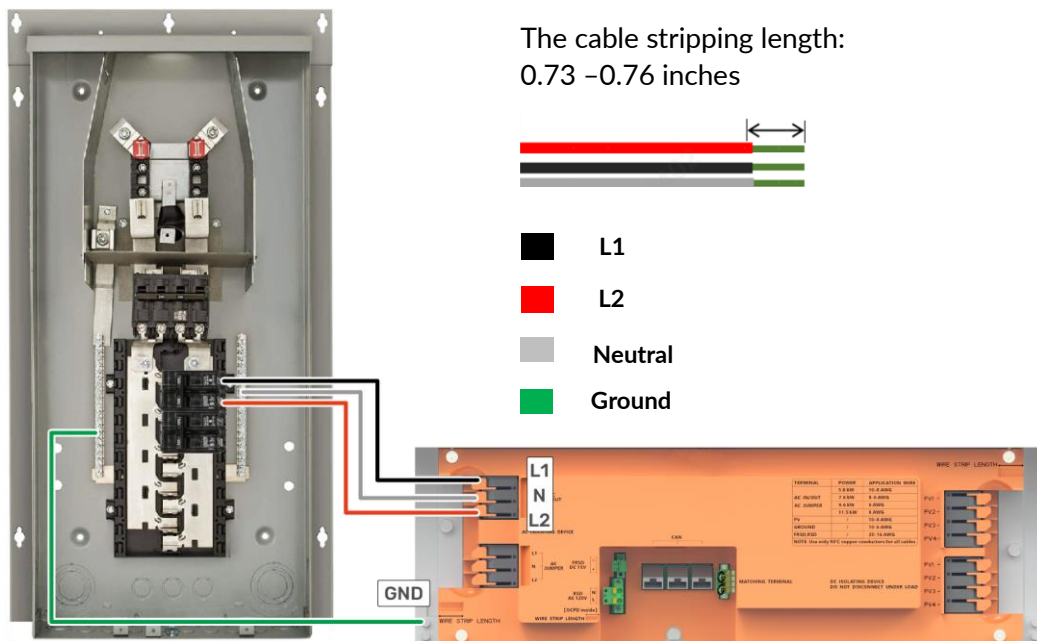

Wring Torque to GND wire:

6 AWG	45 lb·ft (5.1 N·m)
8 AWG	40 lb·ft (4.5 N·m)
10 AWG	35 lb·ft (4.0 N·m)

Wiring for Two or More aPower S

WARNING



A combiner box must be installed when connecting two or more aPower S units to the main distribution panel to ensure system stability and electrical safety.

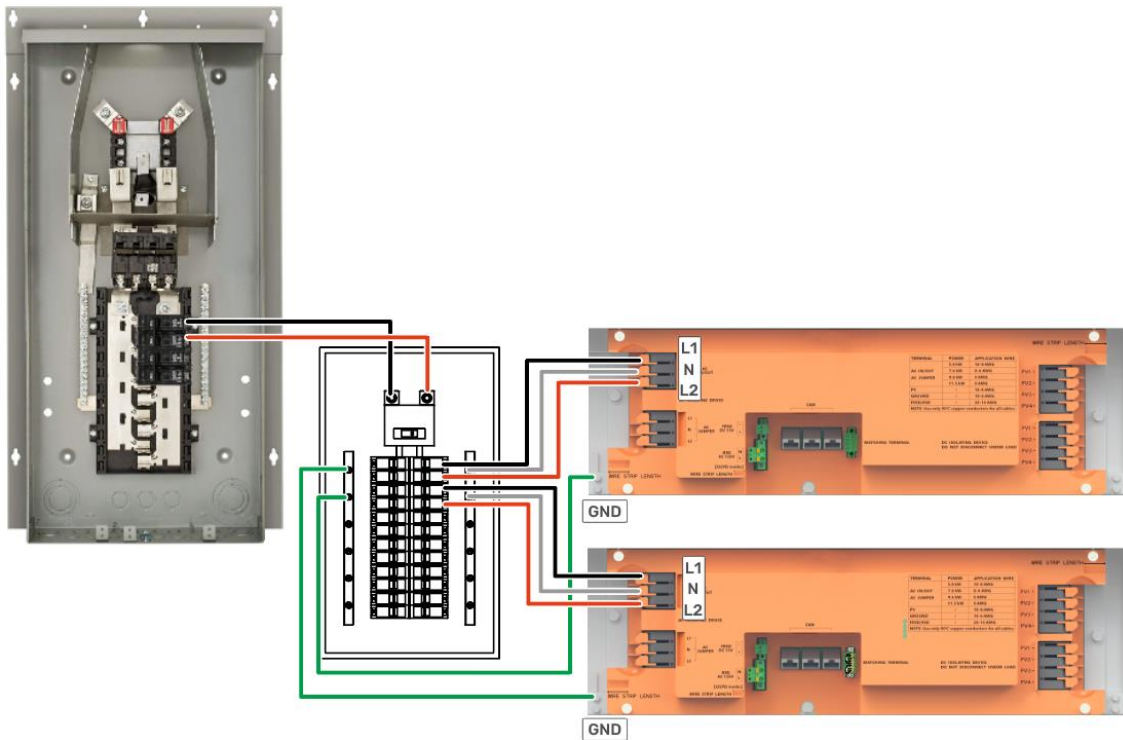

Wring Torque to GND wire:

6 AWG	45 lb·ft (5.1 N·m)
8 AWG	40 lb·ft (4.5 N·m)
10 AWG	35 lb·ft (4.0 N·m)

aPower S + aPower 2 Mixed Configuration

WARNING

A combiner box must be installed when connecting both aPower S and aPower 2 units to the main distribution panel to ensure system stability and electrical safety.

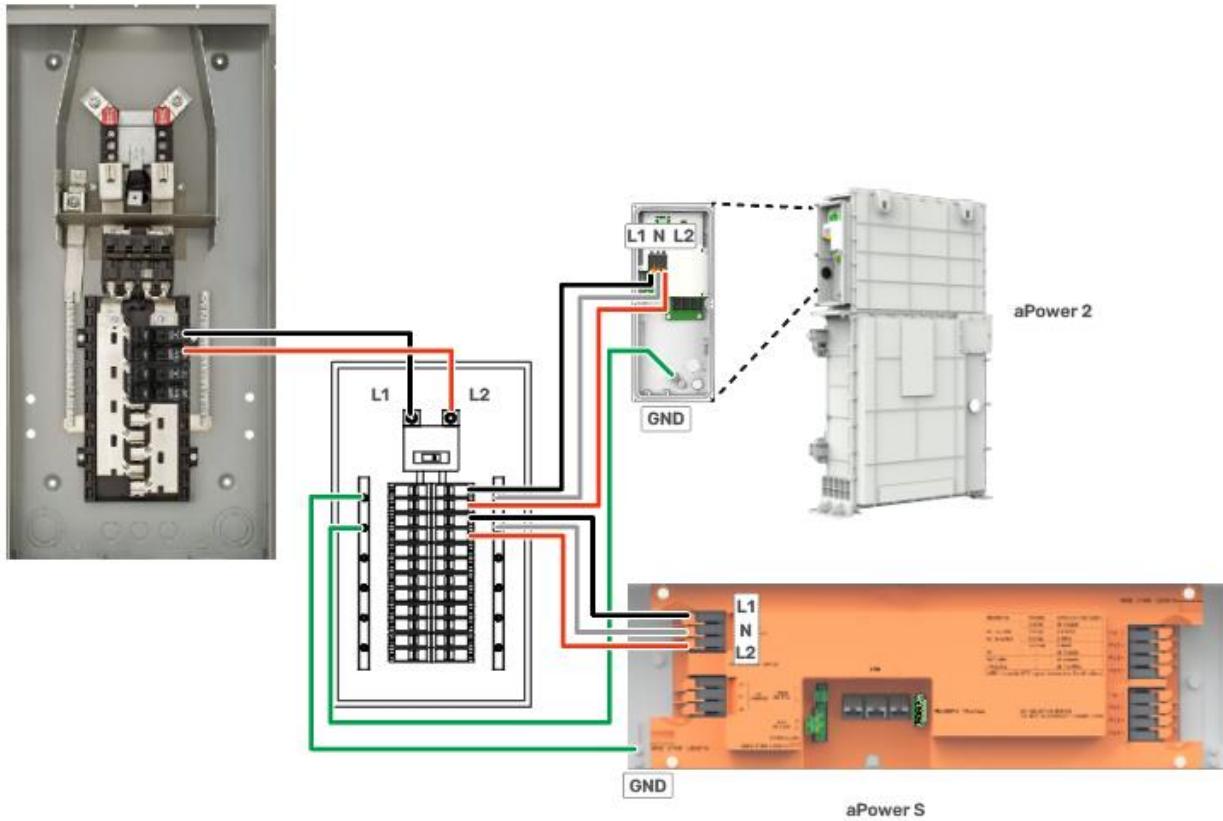

Install the Current Transformer (CT) (Optional)

The PV system is connected to the customer's main panel. PV generation can be connected through an inverter in an on-grid mode. To ensure accurate monitoring of solar energy generation and to trigger the system protection mechanism in the event of excessive generation, a CT is required at the PV connection point for current sampling. Therefore, an external CT must be installed in the FranklinWH System to enable real-time monitoring and management of the solar input current.

Prerequisites

To ensure durability, the CT cables should be passed through conduit to the main panel. Refer to the [Install Electrical Conduit](#) section to complete the installation.

CT Installation



NOTE

Use only CTs approved by FranklinWH or obtained from FranklinWH certified distributors and installers.

WARNING



- Ensure that CT's clamp joint is in tight contact for measurement accuracy.
- Ensure that CTs are installed and wired correctly with correct polarities.
- Ensure that the homeowner's PV system complies with grid connection requirements.

Please refer to the following steps to install additional CTs.

- 1) Power down the system, turn off the upstream and downstream circuit breakers and lock them. Wait at least 5 minutes before performing work.
- 2) A terminal block is preassembled near the lower right corner of the MAC unit. Remove the terminal block by using a 2 mm screwdriver on both ends.

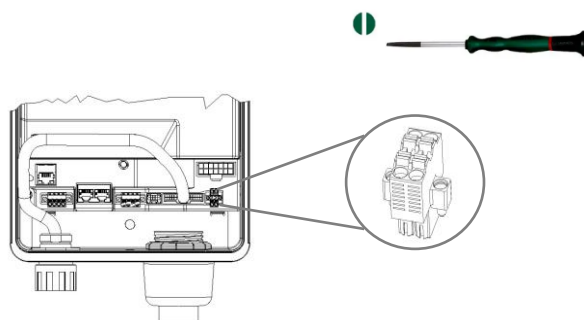

- 3) Strip the CT wires to a length of 0.32 in. (8 mm). Label both ends of each CT wire.

- 4) Pass the CT wires through the 1-1/4" pre-drilled hole at the bottom of the MAC and attach them to the connector, then wire them to the corresponding ports as shown in the diagram.

For a single PV system, the CT wires connect to the connector as shown

White Wire: Connect to the terminal marked **1** (I_PV1 +).

Black Wire: Connect to the terminal marked **2** (I_PV1 -).

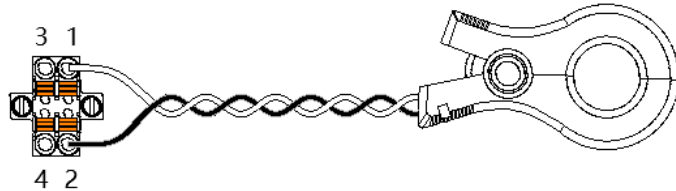

For two PV systems, the CT wires connect to the connector as shown

White Wire: Connect to the terminal marked **3** (I_PV2 +).

Black Wire: Connect to the terminal marked **4** (I_PV2 -).

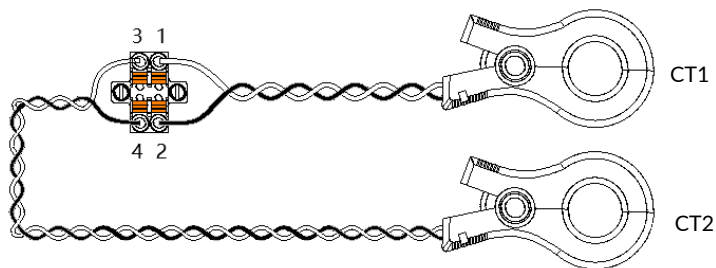

- 5) Once the CT wires are connected, secure the connector to the original interface and use the cable ties to organize the wires.
- 6) The CT's direction is shown on the inside of the handle. Pass the L2 cable through the CT. Clamp the L2 cable in the direction shown below.

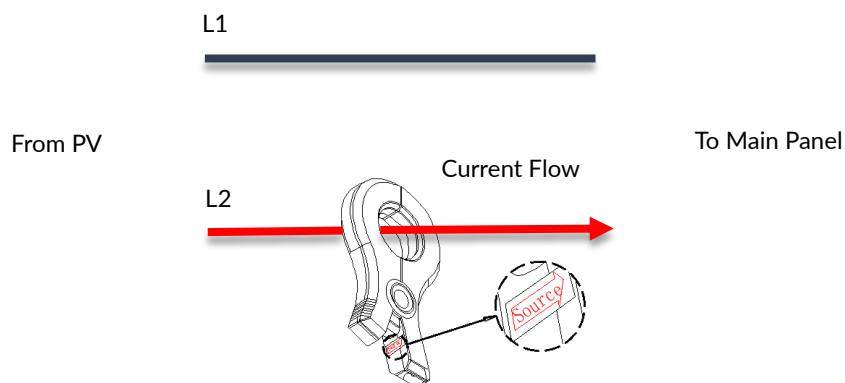

Install an RSD Switch

A Rapid Shutdown Device (RSD) switch may be installed on the MAC to protect against electrical hazards. Activating the RSD switch during installation, maintenance, or emergencies immediately shuts down the DC power from the solar panels to the aPower S. Initiating Rapid Shutdown powers down the storage batteries and triggers rooftop RSD devices.

The Power switch on the aPower S may be used as an RSD initiation switch. However, it will only disconnect the PV strings connected to that specific unit. If the location of the aPower S complies with the requirements of the local AHJ, it is not necessary to install a separate switch.



Single aPower S unit within line of sight of the home's service entrance

- Ensure the RSD jumper in the MAC is in the factory-default position.
- The unit's ON/OFF switch can be used as the rapid shutdown initiator.



Multiple aPower S units or unit not within line of sight of the the home's service entrance

- An External Switch is required.

Installers must procure and install RSD switch according to the local codes and regulations.

Guidelines for RSD Switch Installation:

- RSD devices must be labeled properly according to NEC code.
- Must have an ON/OFF switch that maintains its position after being manually set to either status.
- Must have a clear indication of the ON/OFF positions.
- Must be outdoor rated (NEMA 3R or higher).
- The maximum length of the voltage wire between the RSD switch and the MAC should not exceed 150 feet (45.3 m).
- RSD switch type: Normally Closed (NC)
- The RSD shall have a rated voltage of 5 V or higher.

Installation Procedures

- 1) Before installation, ensure that the MAC is powered off and the MSA communications cable is disconnected.



WARNING: Press the RSD switch to activate the RSD function. At this time, the aPower(s) will be shut off and the relays inside MSA will be disconnected. Auxiliary power remains ON. This ensures safe installation and maintenance work on the PV devices.

The use of the RSD switch is strictly limited to installation and maintenance activities only.

- 2) Remove the factory-installed jumper from the RSD terminal block connector on the MAC.
- 3) Using wire rated at 24-16 AWG, connect pins 3 and 4 (labeled RSD) to the C (common) and NC (normal close) of an external RSD switch.

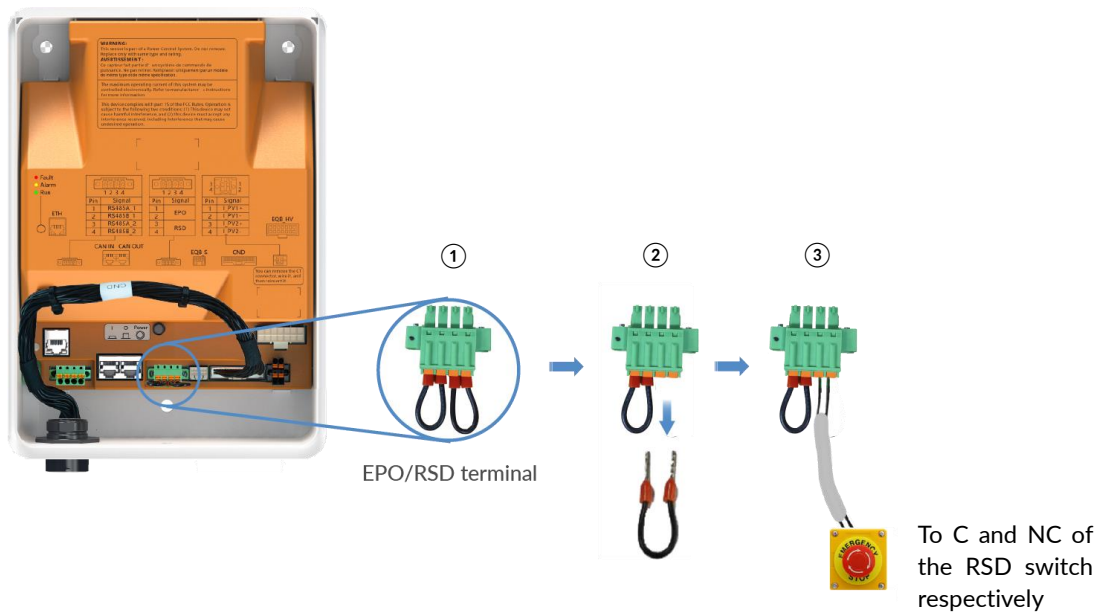

- 4) Make sure the RSD switch is OFF before operating the aPower.

Install an Optional Emergency Power Off (EPO) Switch

When an emergency situation occurs, such as a fire or a smoking battery, the user may manually press the EPO switch button to power off the entire system, when it is safe to do so. The external EPO switch is optional. Consult your local AHJ or Utility before installation.

NOTE



If an external EPO switch is not connected to the FranklinWH System, keep the factory default configuration i.e., the factory-installed EPO terminal block connector on the MAC is short connected as shown in the right figure.



Guidelines for EPO Switch Selection and Installation:

- The notification and marking must be labeled as required by NEC section 706.15(C).
- Must have an ON/OFF switch that maintains its position after being manually set to either status.
- Must have a clear indication of the ON/OFF positions.
- Must be outdoor rated (NEMA 3R or higher).
- The maximum length of the voltage wire between the EPO switch and the MAC should not exceed 150 feet (45.3 m).
- EPO switch type: Normally Closed (NC).
- The EPO shall have a rated voltage of 12 V or higher.

Installation Procedures

- 1) Before installation, ensure that the MAC is powered off and the MAC to MSA cable is disconnected.

WARNING



When the EPO button is pressed, the EPO is in the OFF state. That means the EPO function has been activated to protect the system. At this time, the aPower(s) will be shut off and relays inside MSA will be disconnected. Auxiliary power remains ON.

Do not use the EPO for maintenance operations or in any condition other than an emergency.

-
- 2) Remove the factory-installed jumper from the EPO terminal block connector on the MAC.

- 3) Using wire rated at 16-24 AWG, connect pins 1 and 2 (labeled EPO) to the C (common) and NC (normal close) of an external EPO switch.

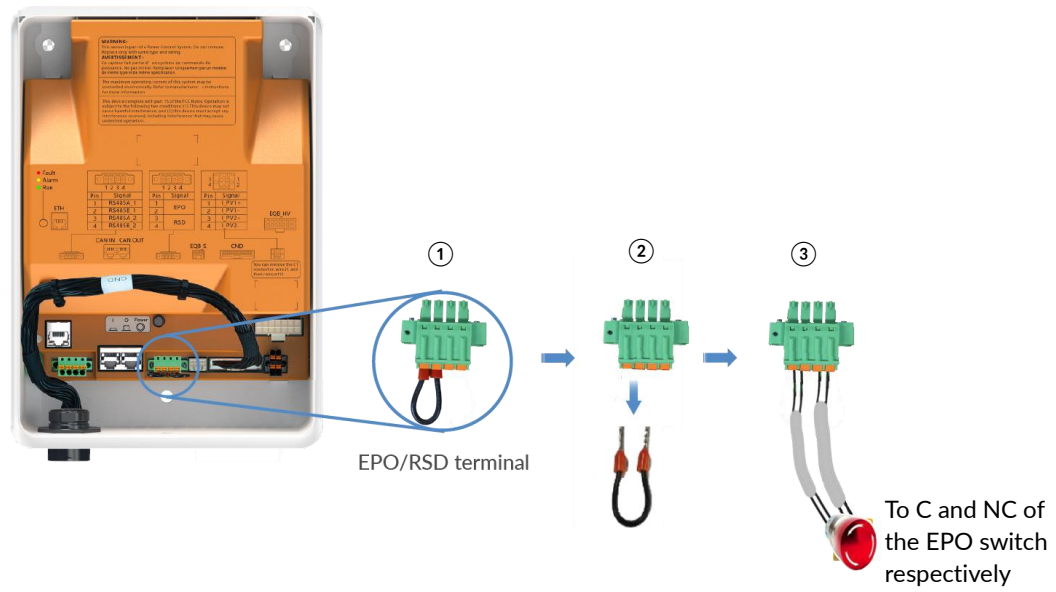

Re-install the MAC Cover

- 1) Hold the cover slightly above the chassis as shown in the diagram, then slide the cover downward to ensure the top is fully engaged.

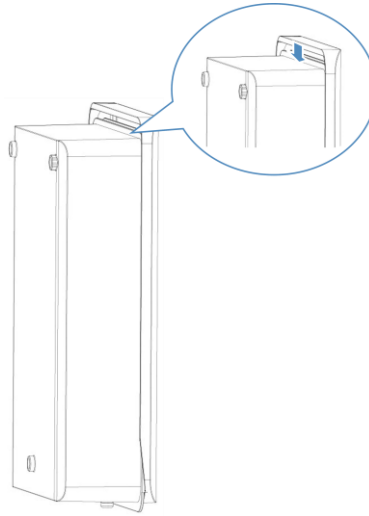

- 2) Tighten the bottom M5 captive screw to 2.21 lb·ft (3.0 N·m).

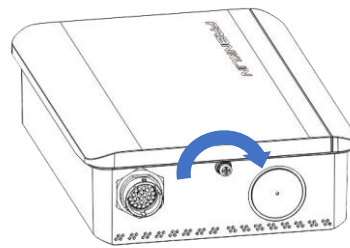

Commissioning and Acceptance

The FranklinWH System installation is complete. For the commissioning and acceptance process, please refer to the *FranklinWH Commissioning Guide*.

Appendix 1: Datasheet

MAC

Nominal AC input voltage (V)	208 Vac, 240 Vac
AC input voltage range	183 ~ 228 Vac, 211 ~ 264 Vac
Nominal AC frequency (Hz)	60 Hz \pm 5 Hz
Nominal DC Input voltage (V)	12 Vdc, 24 Vdc
Rated power consumption	7 W
Operating temperature range	-4° F to 122° F (-20° C to +50° C)
Storage temperature	-22° F to 140° F (-30° C to +60° C)
Operating humidity	Up to 100% RH, condensing
Ingress protection	Type 3R
Protective class	Class II
Dimensions (H x W x D)	11.7 in. x 8.4 in. x 3.3 in. (297 mm x 212 mm x 83.5 mm)
Weight	3.3 lbs. (1.5 kg)
Certificates	UL 1741, UL 1741 PCS, UL 3141, IEEE 1547, IEEE 1547.1, FCC Part 15 Class B, ICES 003, CSA C22.2 No. 107.1-16

Appendix 2: CT Specifications

CT Appearance



CT specifications are shown in the table below.

Type	Specification	Mechanical Specification (mm)
φ24	200 A / 40 mA	

Appendix 3: Drilling and Fastening for Different Walls

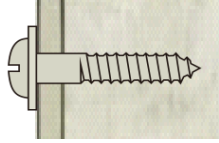
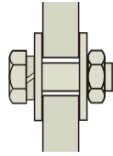
<p>Concrete or brick</p>	<p>Hole depth: Minimum 1-1/2" (38 mm) Fastener: 1/4" (6.35 mm) water-tight washer, spring washer, and nuts</p>	
<p>Wooden beams</p>	<p>Hole depth: Minimum 2.5" (64 mm) Fastener: 1/4" (6.35 mm) water-tight washer, wood screw with a large flat washer</p>	
<p>Steel beams</p>	<p>Hole depth: Through the steel beam Fastener: 1/4" (6.35 mm) water-tight washer, 1/4" (6.35 mm) stainless steel hex screws with spring washer and large flat washer and hex nuts</p>	

Appendix 4: Revision History

REVISION	DATE	DESCRIPTION
V1.0	March 5, 2026	Initial release