



## aPower X Storage and Transportation Guide

Version 1.3.02

Issued on: March. 6, 2024

---

©2023 FranklinWH Energy Storage Inc. All rights reserved.

All information in this Manual is subject to the copyright and other intellectual property rights of FranklinWH Energy Storage Inc. This manual may not be modified, copied or reproduced, in whole or in part, without the prior written permission of FranklinWH Energy Storage Inc.

Please visit [www.franklinwh.com/support](http://www.franklinwh.com/support) for the latest Franklin Home Power documents.

All brands and trademarks mentioned in this document are the property of their respective owners, and their use in this document does not imply the sponsorship or recognition of their products or services.

Please read this document carefully to ensure the best reliability of the product and your warranty eligibility. For further information about warranty, please refer to the **Franklin Home Power Limited Warranty**.

This document is intended for use by professional installation and maintenance service providers only and no statements, information or recommendations in this document constitute any express or implied warranty.

---



Please read this document carefully before installing or using the Franklin Home Power equipment. Failure to follow any instructions or warnings in this document may result in damage to the equipment, personal electric shock, severe injury, or even death.

---

## Product Information

Franklin Home Power (FHP) is composed of aPower, aGate and other electrical components, and this document applies only to the following product: aPower X.

FranklinWH Energy Storage Inc. ("FranklinWH") reserves the right to make any improvements to the product, and the contents in this document shall be subject to updates without further notification.

All images and pictures provided in this Manual are only for demonstration purposes and may differ in detail from the product, based on the product version.

## Feedback

If you have any questions or comments, please send us an email at: [service@franklinwh.com](mailto:service@franklinwh.com)

## Disposal of Scrapped Products

Scrapped products (including their internal chemicals and electrical materials) should not be disposed of with household wastes. Please refer to your local laws and regulations regarding disposal.



## CONTENT

Purpose .....	1
Product Information.....	1
Safety .....	1
Product Parameters.....	2
Packaging .....	2
Dimensions.....	2
Packing List .....	3
Handling .....	4
Storage .....	6
Transportation .....	6
General Guideline for Transportation.....	6
Truck Transportation .....	7
Damaged Parts .....	8

---

## Purpose

This document is provided by FranklinWH Energy Storage Inc. (“FranklinWH”) to its licensed dealers, transportation carriers, storage providers and business partners. It describes the basic information in relation to the packaging, transportation and storage aPower X products. For more information, please contact FranklinWH.

## Product Information

### Safety

aPower X is certified by UN38.3 under the certification number of CN/C530037.

In accordance with the UN38.3 certification rules, the product falls in the category of UN3480, as described in detail below.



UN 3480  
LITHIUM ION BATTERIES

## Product Top



4G/Y250/S/XX  
CN/C530037  
PI:XXX

aPower X is an AC-coupled LFP-based energy storage product. Please refer to the Safety Data Sheet for details of the chemical components. All transportation carriers and cooperative dealers should follow their local laws and regulations in relation to operation safety. If any emergency situation occurs during the storage or transportation process, please handle the product in accordance with the local laws and regulations.

## Product Parameters

Parameters	Description
Battery Rated Voltage	51.2 VDC
Usable Capacity	13.6 kWh
Storage Temperature Range	14 °F ~ 113 °F (-10 °C ~ 45 °C)
Storage humidity	<85% (RH)
aPower X Weight	395 lbs. (179 kg)
Battery Weight	209 lbs. (96 kg)

## Packaging



### NOTE

The outer packaging and the list of accessories are for demonstration purposes only. Depending on product delivery time, details may be slightly different.

## Dimensions

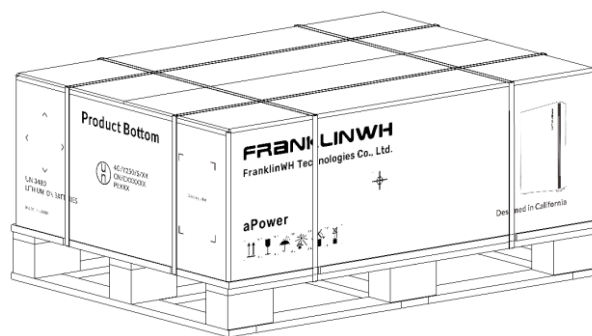

The packaging plan of the aPower X is as shown above. The corrugated cardboard box and internal foam protect the aPower X energy storage system during transportation, storage, and handling. The packaging is designed in line with the Lithium Battery Shipping Regulations 2019 (v.60) from the IATA and the UN Recommendations on the Transport of Dangerous Goods: Manual of Tests and Criteria. The related transportation marks are printed on the exterior packaging.

The package dimensions:

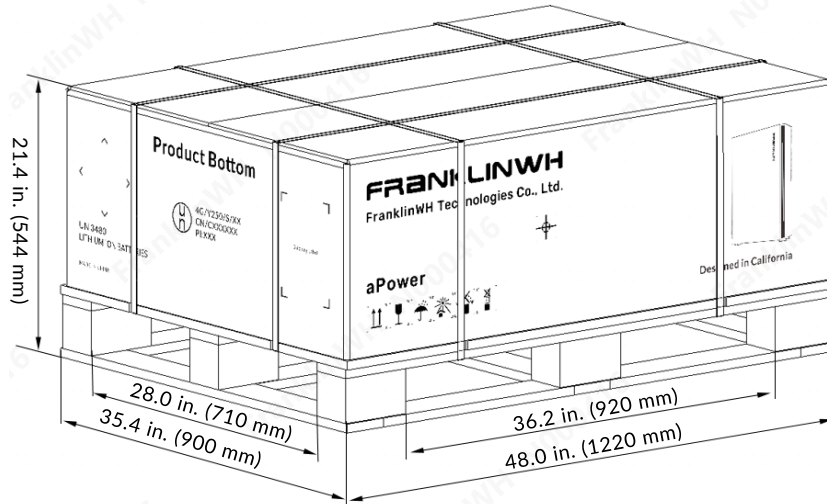

Gross Weight	Length	Width	Height
507 lbs. (230 kg)	48.0 in. (1220 mm)	35.4 in. (900 mm)	21.4 in. (544 mm)
NA	36.2 in. (920 mm)	28.0 in. (710 mm)	NA

## Packing List

Parts and materials in the package include.

- aPower X
- aPower X accessories: grille (3 pcs), mounting bracket (1 pcs), screw (2 pcs), wrench (1 pcs) and retainer plate (2 pcs).

## Handling



### NOTE

During transportation and storage:

- Please make sure that the product remains in the package and is kept in a flat position, with the box underneath, until it is delivered to the installation site.
  - Please make sure that the package is not pierced or damaged and remains well protected from extreme weather and temperatures.
  - Please wear appropriate personal protection equipment, such as gloves and protective shoes, during the handling process.
- 

Please observe the following rules, when handling or storing the units:

- The maximum stacking height is 4 containers, i.e. at most 4 aPower X energy storage systems stored in corrugated cardboard boxes may be vertically stacked.
- If a forklift is used, please handle at most 2 aPower X units at a time. Maximum stacking for handling, 2 units.
- Take care during the handling process to protect the units from impacts, falls, collisions, etc.

Maximum stacking for handling, 2 units:

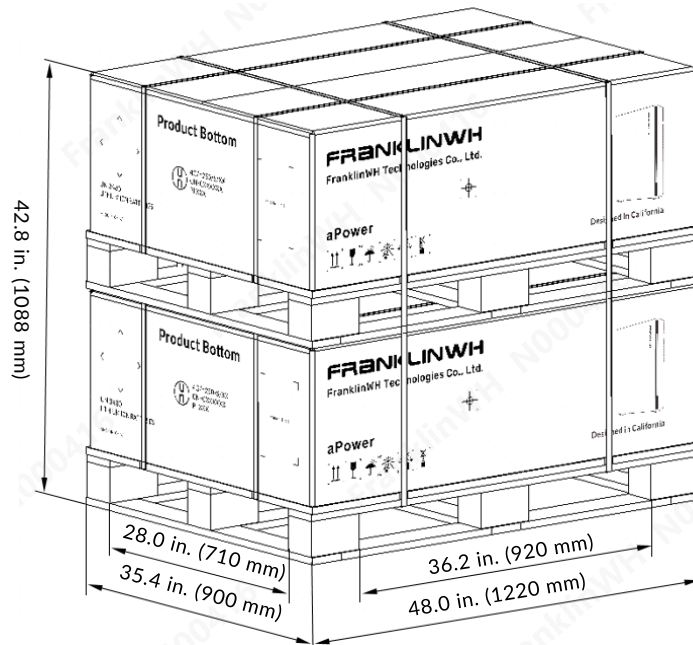

Maximum stacking for storage 4 units:

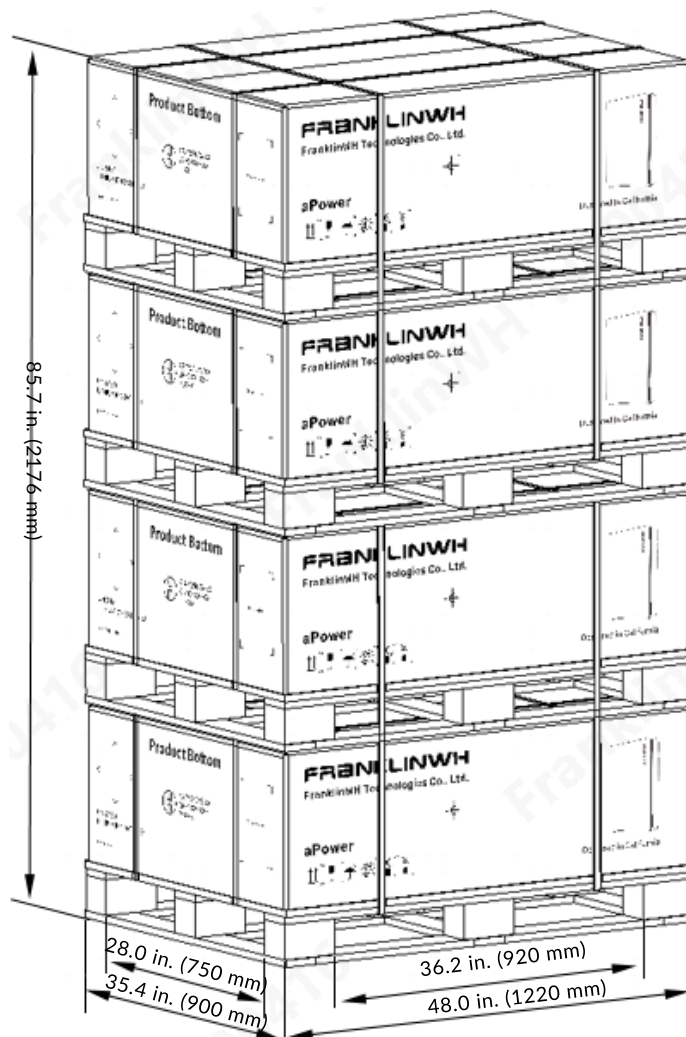



## Storage

Due to the combination of electronic and lithium ion components in the aPower X units, the following guidelines are required for safe storage. Compliance with the storage and transportation requirements will ensure the aPower X stays within the warranty parameters.

- Warehouse storage of the aPower X units should follow the FIFO (First In First Out) principle, and the storage and transportation period should not extend beyond 9 months.
- The aPower X should be stored in a facility with an ambient temperature between 14 °F (-10 °C) and 113 °F (45 °C) and with a relative humidity of less than 85% non-condensing.
- The aPower X unit is shipped with 30% state-of-charge initial power level.
- The internal components of the aPower X may become damaged by heat and UV rays. Please keep the product away from direct exposure to sunshine, excessive heat and open flame.
- The internal electrical components of the aPower X may be damaged by water. Please keep the product well protected from rain and excessive humidity.
- The aPower X should be kept away from corrosive gases and explosives in the storage and transportation process.



### NOTE

The term “storage” in this document refers to:

- Warehouse storage of new FranklinWH products excluding the products stored for initial inventory, maintenance, repair or recycling.
  - The new product is kept in a factory sealed package without any damage.
- 

## Transportation

### General Guideline for Transportation

The aPower X is recognized as a Class-9 dangerous good for commercial transportation (road, railway, air, or sea). The UN code and corresponding title is UN3480, Li-ion battery. The UN code and titles of transportation are identical for all countries and regions.

Every participating dealer should be responsible for training their transportation staff and managers, including those whose job is to prepare related documents for transportation of dangerous goods. Necessary marks or tags indicating the UN3480 hazardous classification are required to be attached to the product packages at all times during transportation and storage of the product and in line with their local transportation regulations and industrial practices.



#### NOTE

- The ownership of and responsibilities for the products will be transferred as the product is delivered. Dealers are responsible for transporting and delivering the product in accordance with the applicable rules and regulations.
- Do NOT place any heavy objects on the product package, as that may damage the corrugated cardboard box or the product.
- The maximum stacking height is 4 units, i.e. at most 4 aPower X energy storage systems stored in corrugated cardboard boxes may be vertically stacked.



## Truck Transportation

In the USA, where trucks are used for transporting aPower X, the carrier company should notify its drivers in an appropriate manner that the goods transported belong to

Class-9 dangerous goods, and the transportation should have the Bill of Lading, worksheet, delivery list and SDS sheet in place. Where truck transportation is used, please follow all local laws and regulations. This product is treated as UN3480 dangerous good under Class 9, whether inside or outside the United States of America.

## Damaged Parts

If the product is found damaged, please attach a high-voltage or electric shock warning sign to the product, before handling the packages and/or other parts in the package. Please visit the official [FranklinWH website](#) and complete the service application in order to receive technical support or information in relation to the damage and/or returning of the product.

For more information, please contact the after-sales service team.

Telephone: +1 888-837-2655

E-mail: [service@franklinwh.com](mailto:service@franklinwh.com)

Website: [www.franklinwh.com](http://www.franklinwh.com)

Address: 1731 Technology Dr., Suite 530, San Jose, CA 95110