



## aHub Installation and Operations Manual

### Version 1.3

aHub, SKU: ACCY-AHUBV1-US

aGate X, SKU: AGT-R1V2-US, AGT-R1V3-US

MAC 1, SKU: MAC-R1V1-US

aPower 2, SKU: APR-10K15V2-US

aPower S, SKU: APRS-10K15V1-US

Jun 16, 2026

©2026 FranklinWH Energy Storage Inc. All rights reserved.

All information in this Manual is subject to the copyright and other intellectual property rights of FranklinWH Energy Storage Inc. This manual may not be modified, copied or reproduced, in whole or in part, without the prior written permission of FranklinWH Energy Storage Inc.

Please visit [www.franklinwh.com/support](http://www.franklinwh.com/support) for the latest FranklinWH documents.

All brands and trademarks mentioned in this document are the property of their respective owners, and their use in this document does not imply the sponsorship or recognition of their products or services.

Please read this document carefully to ensure the best reliability of the product and your warranty eligibility. For further information about warranty, please refer to the **FranklinWH System Limited Warranty**.

This document is intended for use by professional installation and maintenance service providers only and no statements, information or recommendations in this document constitute any express or implied warranty.

---



Please read this document carefully before installing or using the FranklinWH equipment. Failure to follow any instructions or warnings in this document may result in damage to the equipment, personal electric shock, severe injury, or even death.

---

## Product Information

The FranklinWH aHub enhances home energy distribution by supporting multiple energy inputs and integrating household loads, controlled by the FranklinWH Meter Adapter Controller (MAC 1) or FranklinWH aGate X.

FranklinWH Energy Storage Inc. (FranklinWH) reserves the right to make any improvements to the product, and the contents in this document shall be subject to updates without further notification.

All images and pictures provided in this manual are only for demonstration purposes and may differ in detail from the product based on the product version.

### FCC Supplier's Declaration of Conformity

This device complies with part 15 of the FCC Rules. Operation is subject to the following two conditions:

- (1) This device may not cause harmful interference, and
- (2) This device must accept any interference received, including interference that may cause undesired operation.

### Feedback

If you have any questions or comments, please send us an email at: [service@franklinwh.com](mailto:service@franklinwh.com)

### Disposal of Scrapped Products

Scrapped products (including their internal chemicals and electrical materials) should not be disposed of with household waste. Please refer to your local laws and regulations regarding disposal.



## CONTENT

Safety Statements.....	1
Important Information .....	1
Safety Symbols .....	1
Safety Instructions.....	2
Warranty Statement.....	3
Service and Maintenance .....	4
Service.....	4
Maintenance .....	4
Product Overview.....	5
Components and Features .....	5
Specifications.....	6
Application .....	7
aHub with MAC 1.....	7
Scenario A: aHub Connection to the Main Panel.....	7
aHub with aGate .....	9
Scenario B: aHub Connection to Line-Side Main Panel.....	9
Scenario C: aHub Connection to the aGate Backup Port Subpanel.....	11
Scenario D: aHub Connection to the aGate Non-Backup Port Subpanel.....	13
aHub Installation.....	15
Preparation.....	15
Site Planning .....	15
Tools Needed.....	16
Unboxing.....	17
Installation .....	18
Drill Holes on the aHub .....	18
Mount the aHub on a wall.....	19

---

Install breakers as needed .....	21
Wiring.....	22
Install Electrical Conduit.....	22
Communications connections .....	23
Electrical Wiring .....	31
Connect the aHub to the Main Panel .....	38
Complete Installation .....	39
Configure the aHub using the FranklinWH App .....	40
Technical Support .....	40
Appendix 1: Allowed Breakers.....	41
Appendix 2: Revision History .....	44





## Safety Statements

### Important Information

The FranklinWH aHub is an electrical device. Please read this entire document to ensure proper use. Please strictly follow the safety instructions described in this manual during operation, otherwise it may result in equipment malfunction, electrical shock, serious injury or death, and void the warranty.

### Safety Symbols













This Manual contains the following safety symbols.

	<p><b>DANGER:</b> This indicates a hazardous situation which, if not avoided, may result in death or serious injury.</p>
	<p><b>WARNING:</b> This indicates a situation where failure to follow instructions may be a safety hazard or cause equipment malfunction. Use extreme caution and follow instructions carefully.</p>
	<p><b>NOTE</b> This indicates information that is important for optimal system operation. Closely follow instructions.</p>
	<p><b>ELECTRONIC DEVICE: DO NOT THROW AWAY!</b> All scrapped products (including their internal chemicals and electrical materials) should not be disposed of with household waste. Please refer to your local laws and regulations regarding disposal.</p>

\* The DANGER, WARNING, and NOTE alerts are supplemental to the safety instructions and are not exhaustive.





## Safety Instructions

### General Information

	<b>DANGER:</b> The installation, wiring, maintenance, transportation, and handling of the aHub should follow local laws, regulations and standards, and the Safety Instructions in this Guide serve as supplementation to the laws, regulations and standards.
	<b>DANGER:</b> The aHub is electrical equipment that, when used improperly, can present a risk of electrical shock and fire, and misuse may void the warranty. Only FranklinWH certified and qualified electricians should install, maintain or replace the equipment or wiring. Workers must wear personal protective equipment (PPE) during operation.
	<b>DANGER:</b> The aHub should be installed away from heating equipment, or any source of heat and/or fire.
	<b>DANGER:</b> It is strictly forbidden to install, maintain or handle aHub units outdoors during bad weather such as thunder, rain, snow and high winds.
	<b>DANGER:</b> It is strictly forbidden to work on or operate an aHub alone. For safety, make sure that there is someone around you who can help.
	<b>DANGER:</b> During electrical maintenance, turn off Vehicle to Load (V2L) and generator output (if applicable). Disable the auto start/stop function on standby generators to prevent accidental startup and avoid safety hazards like electric shock or short circuits.
	<b>DANGER:</b> To prevent accidents and injuries, it is highly recommended to follow Lockout/Tagout best practices on upstream and downstream switches during installation or maintenance.
	<b>WARNING:</b> During the transport and handling of an aHub, extreme care is required to avoid dropping, bumping, stomping, or inverting the equipment.
	<b>WARNING:</b> When installing and maintaining an aHub, avoid any foreign objects being inserted or dropped into the enclosure.
	<b>WARNING:</b> Only use parts or accessories purchased from FranklinWH or a FranklinWH-certified party.
	<b>WARNING:</b> Do not paint any part of the aHub unless the paint surface of the equipment housing is accidentally damaged during transport, installation or maintenance. The damaged part can be repaired with paint or topcoat of the same color.
	<b>WARNING:</b> If any equipment failure occurs, please contact your installer or after-sales service provider for support. Do not attempt to take apart, repair

	and/or modify an aHub without the authorization of FranklinWH. Otherwise, it may lead to safety hazards and void your warranty.
	<b>WARNING:</b> Do not use an aHub if there is functional or cosmetic damage noticed after unboxing (except for slight paint damage). Contact after-sales service for support.

**During the installation, use, storage, and transport of equipment:**

	<b>DANGER:</b> Keep away from flammable and explosive materials.
	<b>WARNING:</b> Install in dry, cool and well-ventilated location for satisfactory performance.
	<b>WARNING:</b> Install away from standing water or from areas that can pool water.
	<b>WARNING:</b> Keep way from water sources including downspouts, sprinklers, faucets and liquid containers. The aHub installation site should have no water sources above it or in the vicinity, including water pipes, shower, faucet, and containers of liquids.
	<b>WARNING:</b> This product can expose you to lead, which is known to the State of California to cause cancer, birth defects or other reproductive harm. (For more information go to <a href="http://www.p65warnings.ca.gov">www.p65warnings.ca.gov</a> ).
	<b>NOTE:</b> It is best practice to avoid a direct south-facing orientation when installing outdoors for optimal performance.

## Warranty Statement

To meet warranty requirements, FranklinWH aHub products must be installed and operated properly according to the instructions in related FranklinWH documents.

To secure the full warranty, the FranklinWH aHub products must be reliably connected to FranklinWH System to access remote services provided by FranklinWH.

Please visit us at [www.franklinwh.com/support](http://www.franklinwh.com/support) to learn more about the warranty.

## Service and Maintenance

### Service

- Keep the equipment away from leaves or other foreign materials, especially keep objects from the top of the unit and keep the space clear between the unit and the back wall.
- It is best practice to install the aHub in an area protected from direct sunlight, rain and snow. Extreme heat from direct sunlight may affect equipment longevity beyond the warranty period.
- Keep all equipment in an environment with acceptable temperature and humidity.
- Clean the equipment surface using a soft cloth. If water is needed, please make sure the cloth is slightly damp (water only) and the equipment is completely de-energized.
- Don't block the vents.
- Keep the equipment away from flammable, explosive, and/or poisonous materials.
- Keep the equipment operating within the allowed power range and avoid overloading.
- Make sure all cables are wired reliably and all connectors are free of stress.
- Keep the equipment away from hazardous zones and potential risks.
- A nearby smoke detector is recommended if the equipment is installed indoors.

### Maintenance

- Please check the running status of your equipment on your mobile app. If any alarm is found, please contact the qualified service group.
- Never attempt to repair the system by yourself. Contact professionals certified by FranklinWH.

## Product Overview



The aHub is designed to be used in the FranklinWH System. The aHub enhances home energy distribution by supporting multiple energy inputs and household load integration. Managed by the FranklinWH Meter Adapter Controller (MAC 1) or aGate, it enables advanced energy dispatch strategies and intelligent resource management.

## Components and Features

The aHub includes the following components and features.



After installation, ensure the RST button is released and the Status indicator LED is illuminated. If the system is at fault, press the RST button to perform a system reset.



Power ON



Power OFF

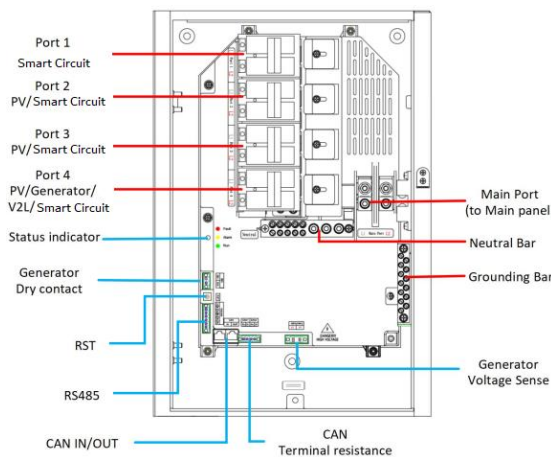

- Solar Optimization:** Accommodates up to three AC-coupled PV arrays with 24 kW total capacity, maximizing renewable energy utilization for Net Energy Metering (NEM) applications and retrofit installations.
- Smart Circuit Management:** Configurable circuit architecture supports up to 4×240 V or 8×120 V circuits with programmable scheduling and remote control via the FranklinWH App, enabling customized energy consumption patterns.
- Generator Compatibility:** The aHub supports 240 V standby and portable generators connections for reliable backup during prolonged outages.
- Vehicle-to-Load (V2L) Compatibility:** Leverages electric vehicles with V2L capability as alternative power sources for enhanced flexibility.

## Specifications

Electrical Specifications	
Nominal Voltage	120 / 240 Vac, split
Frequency	60 Hz
Port 1	Smart Circuit
Port 2	PV/Smart Circuit
Port 3	PV/ Smart Circuit
Port 4	Generator/V2L/PV/Smart Circuit
Overcurrent Protection Device	Main Port: 125 A Port 1: 60 A Port 2: 60 A Port 3: 60 A Port 4: 100 A
Rated Current	Main Port: 100 A Port 1: 48 A Port 2: 48 A Port 3: 48 A Port 4: 80 A
Warranty	15-year
Mechanical Specifications	
Dimensions (W x H x D)	13.0 in. x 18.9 in. x 5.1 in. (330 mm x 480 mm x 130 mm)
Weight	14 lbs (6.5 kg)
Mounting	Wall mount
Environmental Specifications	
Operating Temperature Range	-4° F to 122° F (-20° C to 50° C)
Storage Temperature Range	-22° F to 140° F (-30° C to 60° C)
Operating Humidity (RH)	Up to 100% RH, condensing
Maximum Altitude	9843 ft (3000 m)
Enclosure Type	NEMA 3R
Compliance Information	
Compliance	UL1741, UL1741 PCS, UL3141 CSA C22.2 No.107.1-16, FCC PART15 CLASS B

**COMPATIBILITY:** The aHub is compatible with the FranklinWH Meter Adapter Controller (MAC), aGate 1.3, aGate 1.3.1, aPower 2, and aPower S.

# Application

## aHub with MAC 1



**WARNING:** Before connecting the generator or EV to the aHub, make sure the non-relay-controlled PV system is connected to the aHub. If the PV system is connected to the main panel, there is a risk of damaging the generator or EV, so this connection method is prohibited.

### Scenario A: aHub Connection to the Main Panel

Figure 1: aHub Communications via CAN Port

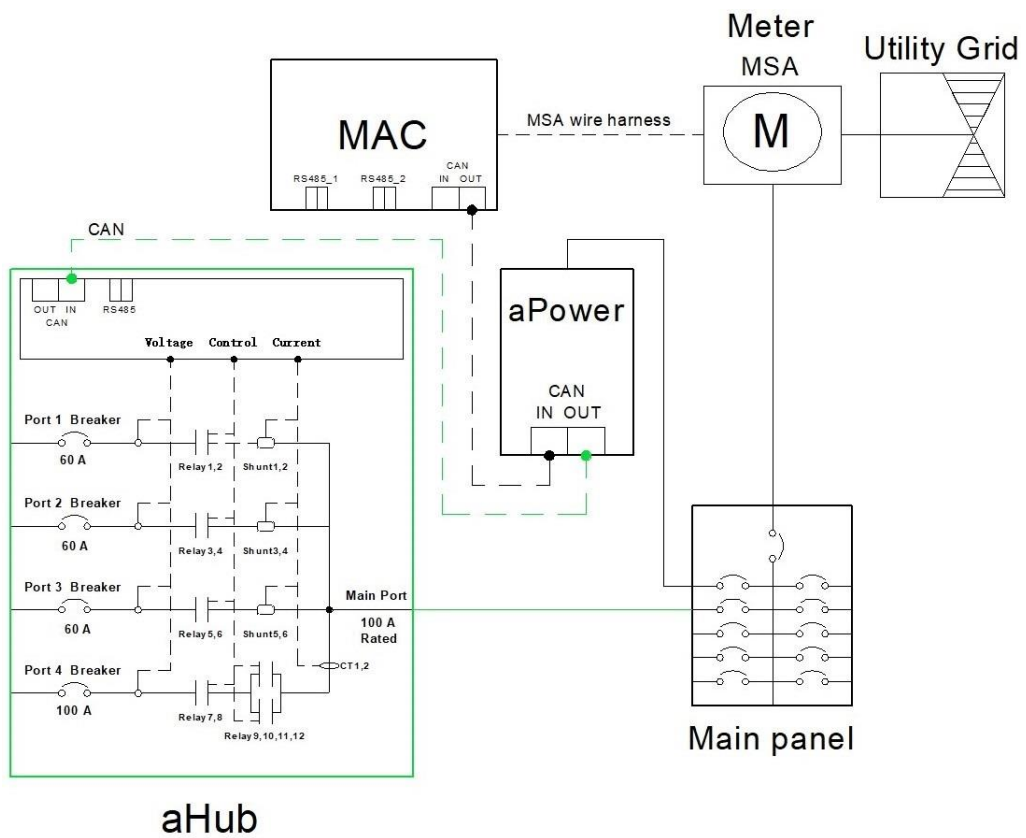
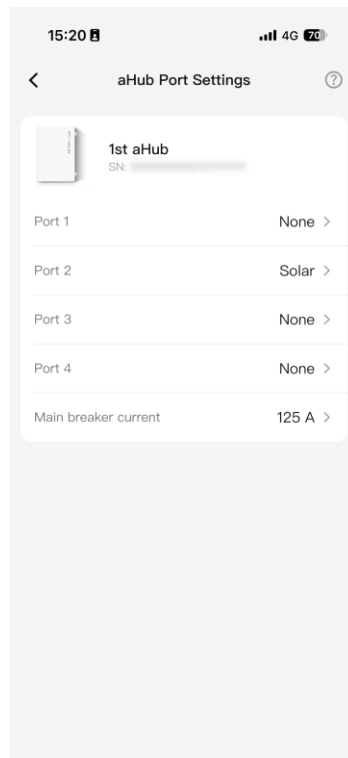
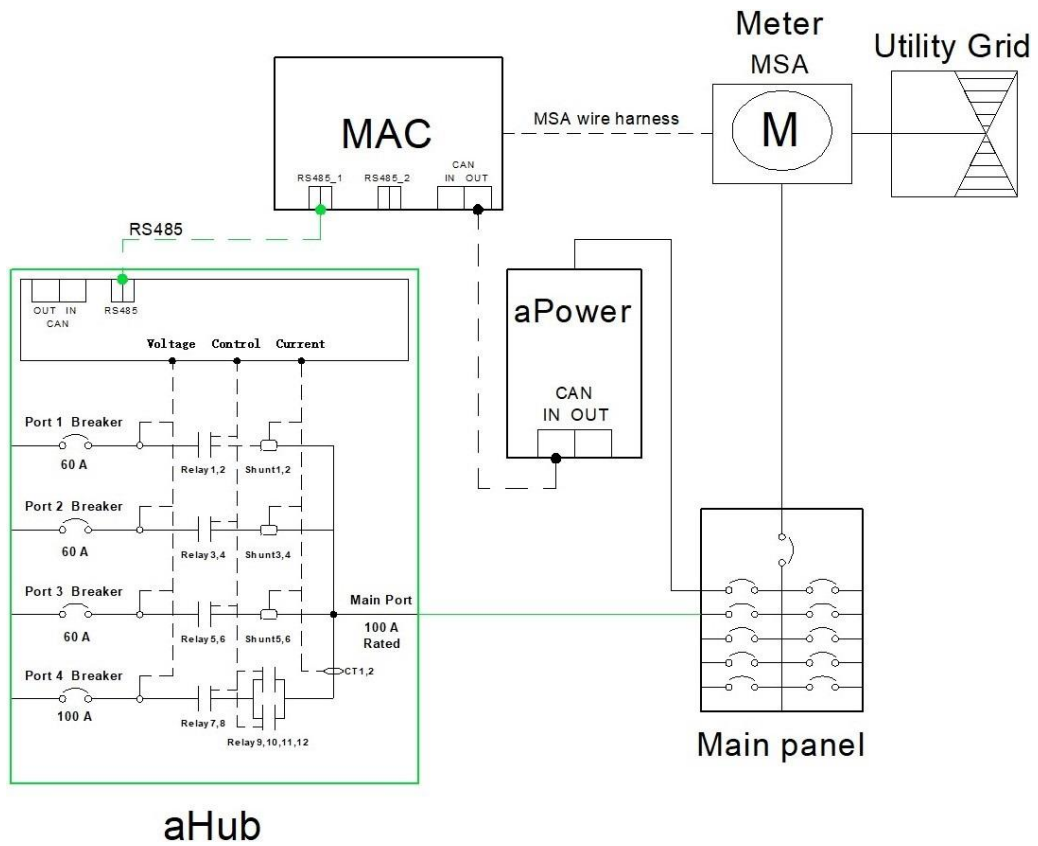

Figure 2: aHub Communications via RS485 Port



## aHub with aGate

### Scenario B: aHub Connection to Line-Side Main Panel

The aGate and aHub are connected to the grid via the main panel.

**Note:** When the aHub is installed line side, the generator or EV cannot be connected to the aHub and must be connected to the aGate.

Figure 3: aHub Communications via CAN Port

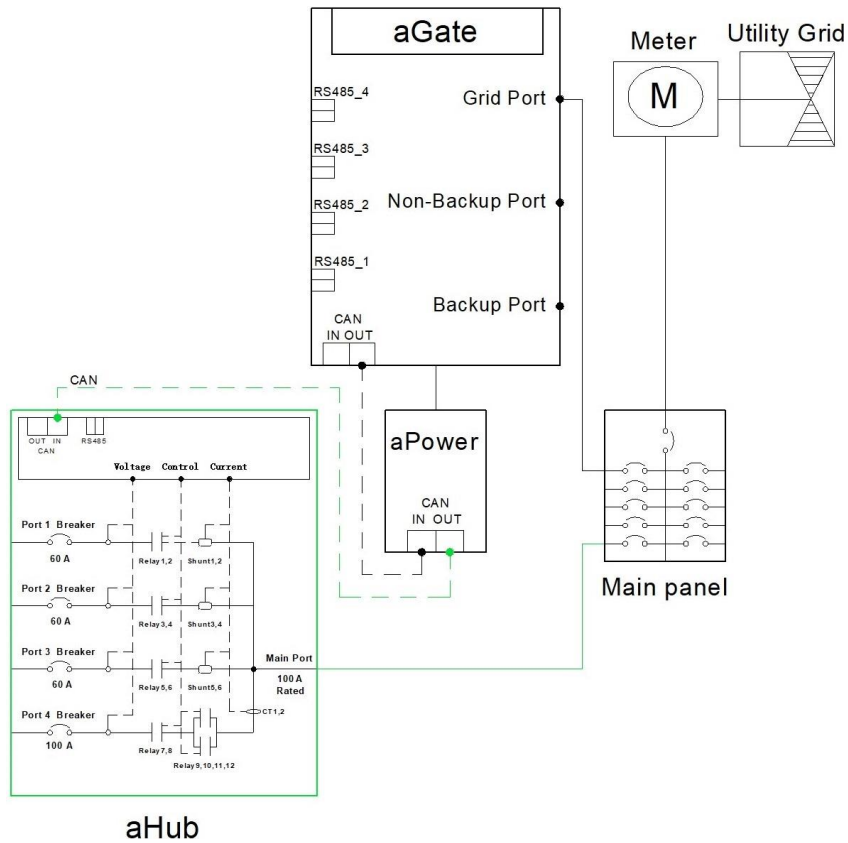
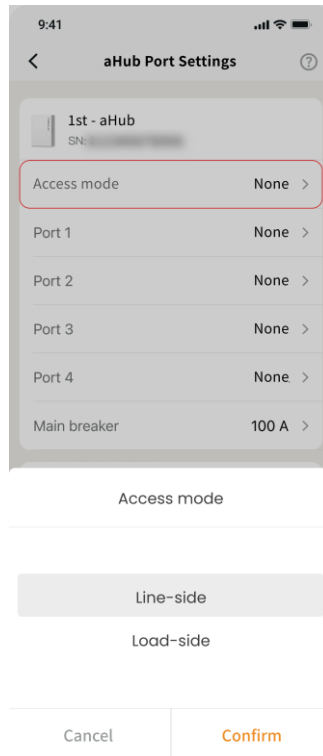
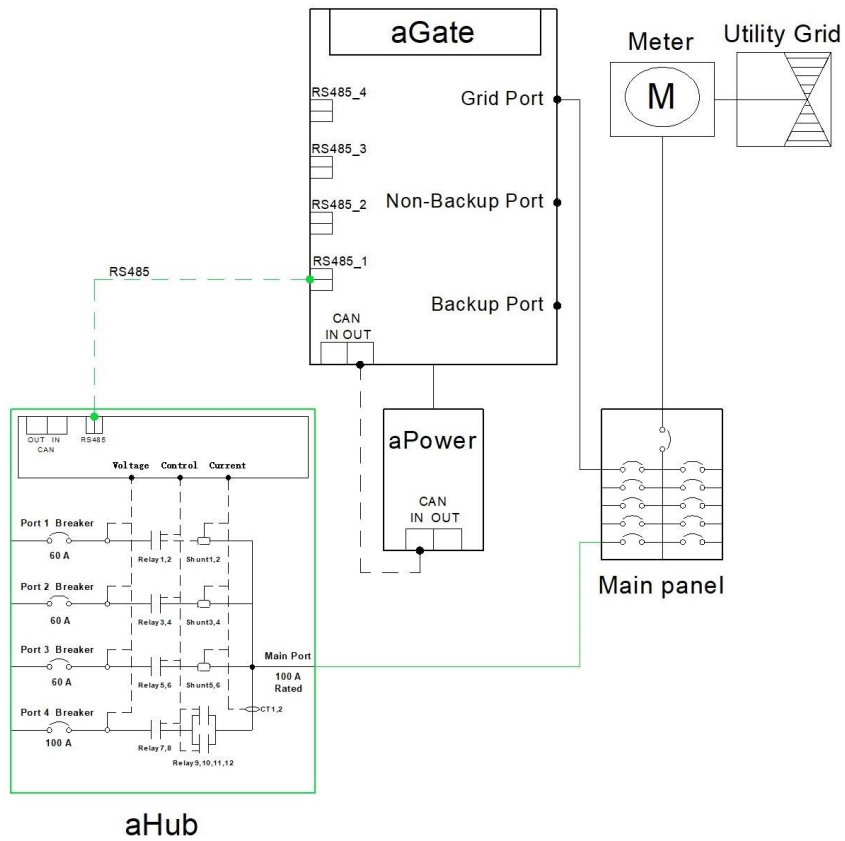

Figure 4: aHub Communications via RS485 Port



### Scenario C: aHub Connection to the aGate Backup Port Subpanel

The aGate is directly connected to the utility grid. The aHub is connected to the backup port of the aGate via the subpanel.

*Note: In this scenario, the generator or EV can be connected to the aHub.*

Figure 5: aHub Communications via CAN Port

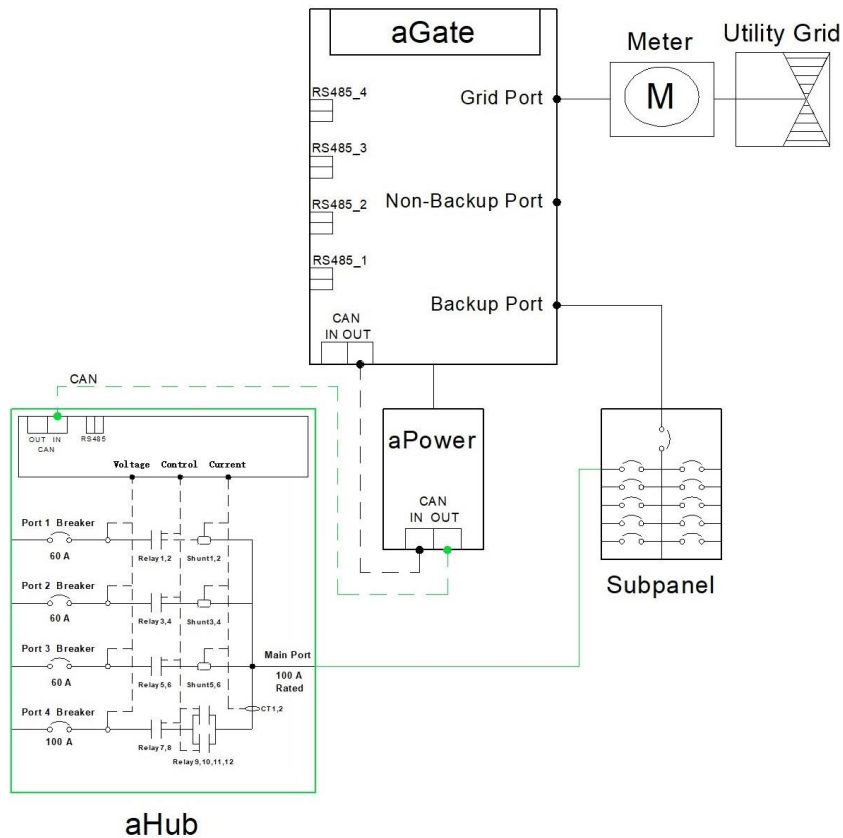
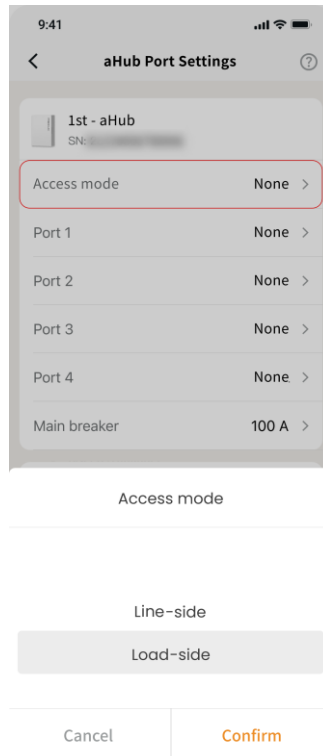
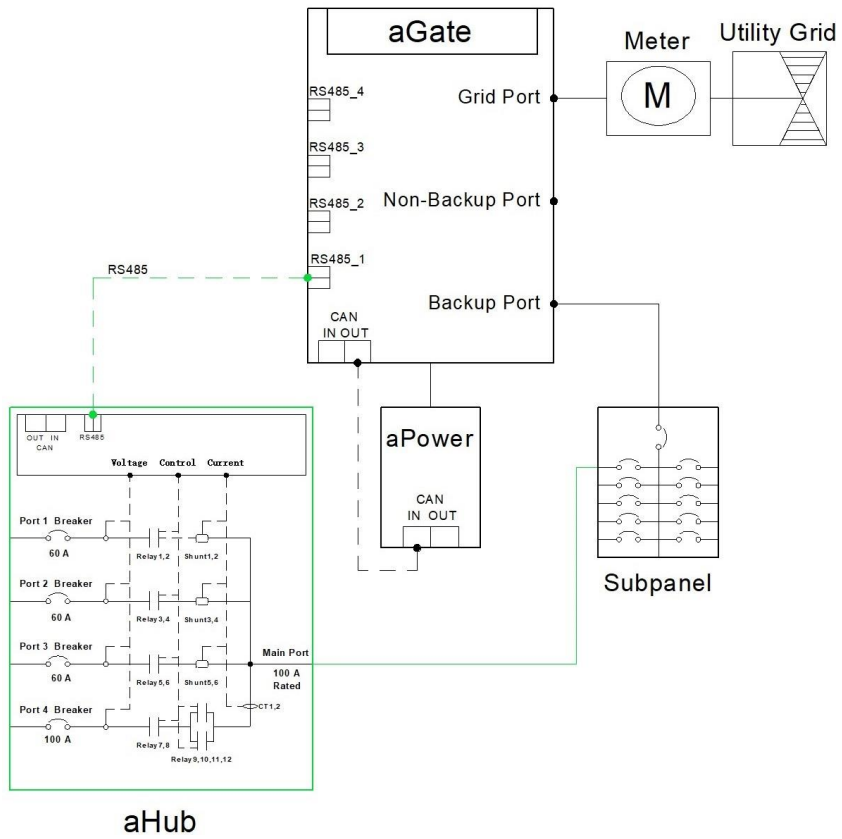

Figure 6: aHub Communications via RS485 Port



### Scenario D: aHub Connection to the aGate Non-Backup Port Subpanel

The aGate is directly connected to the utility grid. The aHub is connected to the non-backup port of the aGate via the subpanel.

**Note:** In this scenario, the generator or EV cannot be connected to the aHub and must be connected to the aGate.

Figure 7: aHub Communications via CAN Port

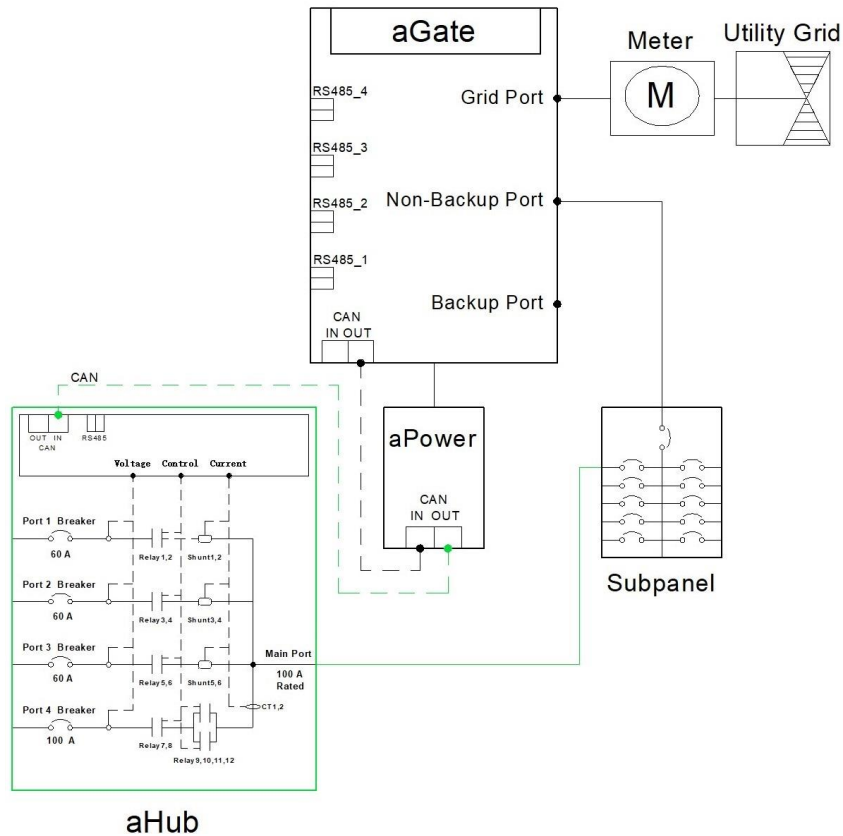
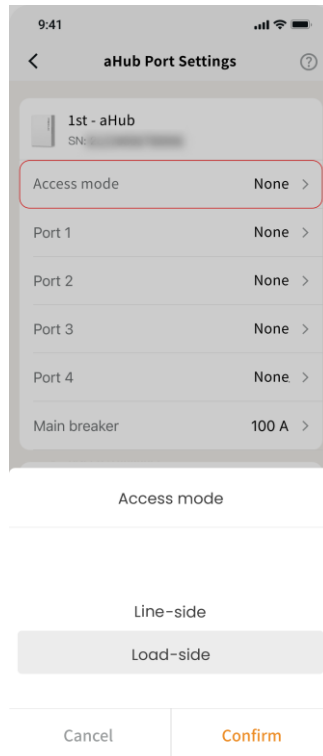
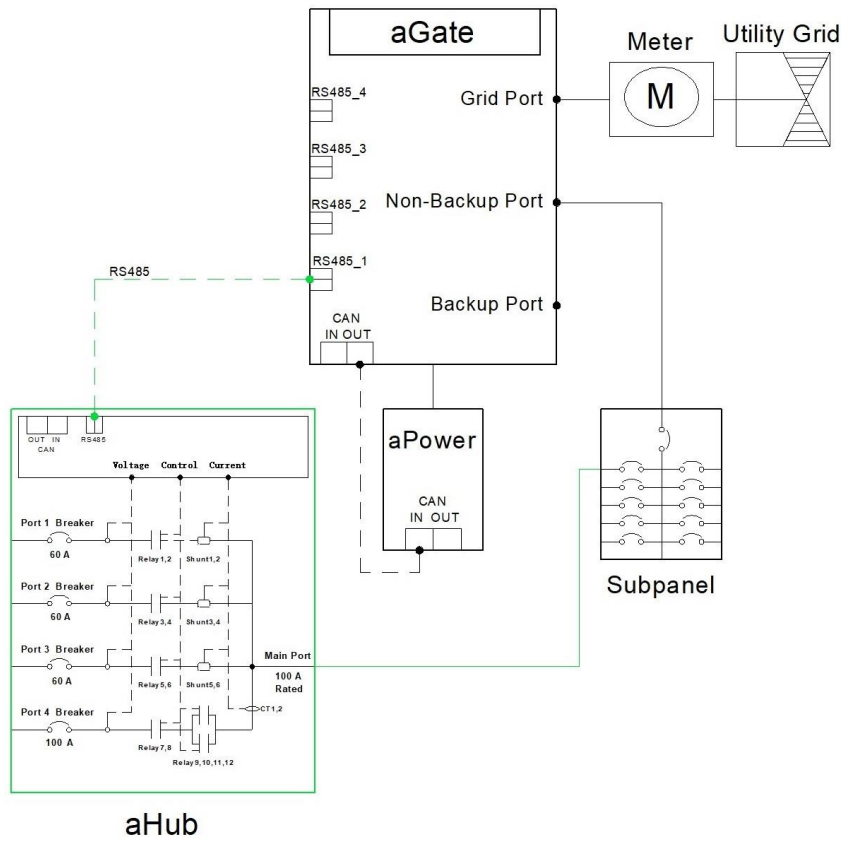

Figure 8: aHub Communications via RS485 Port



## aHub Installation

### Preparation

#### NOTE



Since the aHub requires an AC power connection to operate and complete commissioning, it is recommended for on-grid installations to happen with the grid connected. For off grid installations, normal commissioning and updating must be completed before aHub commissioning.

### Site Planning

For a wall-mounted aHub, there should be a minimum clearance of 6 in. (0.15 m) from the top of aHub to the ceiling, and 36 in. (0.91 m) of clearance in front of the aHub.

The maximum distance between the bottom of the aHub and the ground shall be less than or equal to 60 in. (1.52 m). Additionally, a minimum clearance of 6 in. (0.15 m) should be provided on both sides of the aHub.

**Note:** *If there are electrical conduit cables below the left or right side of the aHub, or nearby equipment may obstruct its operation, ensure additional space is provided as needed.*

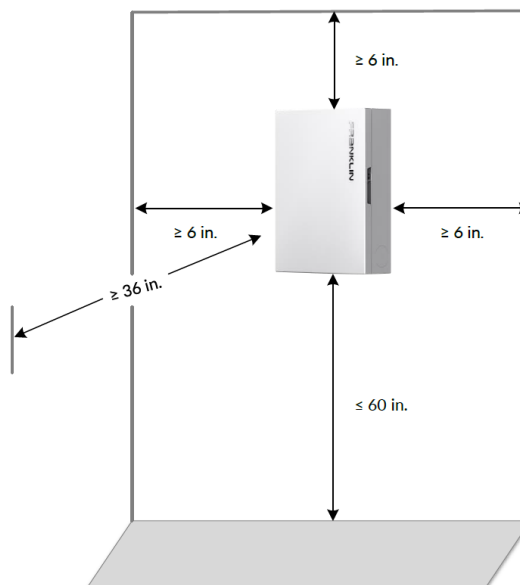

## Tools Needed

Ensure that you have the following before installation:

- **Personal protective equipment (PPE) (goggles, gloves, protective shoes, anti-dust respirator, etc.) for personal safety.**
- **Drill.**
  - Use 5/32" Brad Point Bits or 5/32" Auger bits to drill pilot holes in wooden walls.
  - Use 1/2", 3/4", 1", 1-1/2", 2" sized wood bits to create holes in wooden walls.
  - Use 1/2", 3/4", 1", 1-1/2", 2" sized hole saw bits to create holes in metal walls.
- **Hammer drill.**
  - Use 1/2", 3/8" Masonry bits to create pilot holes on concrete or brick walls.
  - Use 1/2", 3/4", 1", 1-1/2", 2" Diamond core bits to create holes in concrete or brick walls.
- **Electric screwdriver and cross screw bits to tighten the fastening screws.**
- **Torque wrench and bent-handle ratchet wrench.**
  - 3/16" inner hex screwdriver bits to fasten cables at circuit breakers and pressure connectors and to check the torque.
  - 3/16", 1/4" straight screwdriver bits to fasten cables at circuit breakers and connectors and to check the torque.
  - PH2, PH3 cross screwdriver bits to fasten cables at circuit breakers and to check the torque.
  - 6" ratchet extension.
- **Flat head screwdriver (1/8" x 4", 1/4" x 4") to fasten signal terminals.**
- **Phillips head screwdrivers (PH#2 x 4", PH #3 x 4") to tighten fasteners.**
- **Utility knife.**

Used for unboxing.
- **Wiring tools.**

Wire stripper, Wire cutter, Utility wire shear.
- **Stud finder.**

Detects the location of the wires in the wall to prevent short circuits before drilling.
- **Multimeter.**

Used to measure the voltage and current.
- **Work light.**

For lighting during power-off.
- **Level.**

Used to install the aHub level.
- **Marker.**

Marks the mounting hole location.
- **Camera.**

Records the installation process.

- **Deep Cut Band Saw.**  
For thin-walled steel pipe or PVC pipe cutting.
- **Knockout Tool Kit.**  
Used to enlarge the hole or to make new holes when the conduit diameter is larger than the aHub knockout hole, or if any new hole needs to be made.
- **Wooden block, size: 1.75 in. × 26.77 in. × 2.36 in. (44.4 mm × 680 mm × 60 mm).**
- **Adjustable wrench, size: 0-1.97 in. (0-50 mm).**
- **6", 10", 18" pipe wrenches.**

## Unboxing

**Step 1** Inspect the packaging for damage.

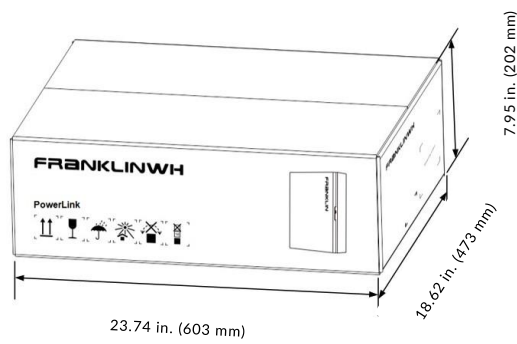

**Step 2** Use a retractable utility knife to cut open the sealing tape of the package box, with the knife blade shorter than 0.3 in. (7.62 mm) to avoid damaging the aHub case.

**Step 3** Remove the box contents and check for the following items:

- One aHub
- One accessory bag including the following:
  - i. Three 1/4" water-tight washers
  - ii. Five cable ties
  - iii. Labels

## Installation

### Drill Holes on the aHub

The aHub enclosure has no pre-drilled knockouts. Holes need to be drilled based on the actual wiring layout at the installation site.

**Step 1** Grasp the small notch on the right side of the aHub. Lift it slowly until the door of aHub is completely open, as shown in the following figure.

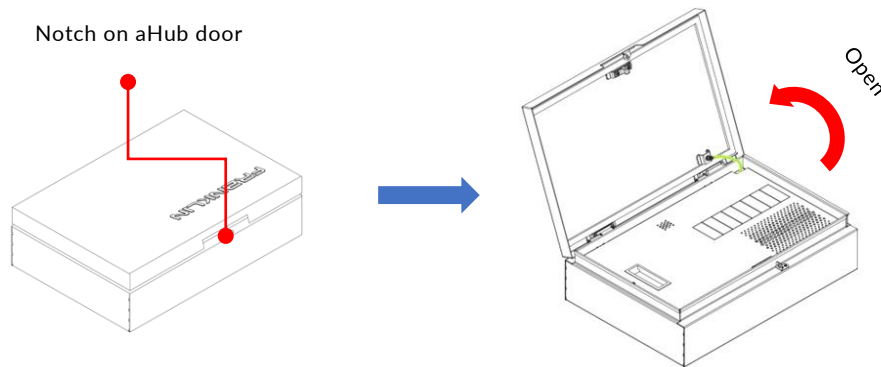

**Step 2** Follow the diagram below for proper installation, ensuring the red area is for the power cable entry and the purple area for the communications cable entry. This will prevent water from entering the enclosure and causing malfunctions.

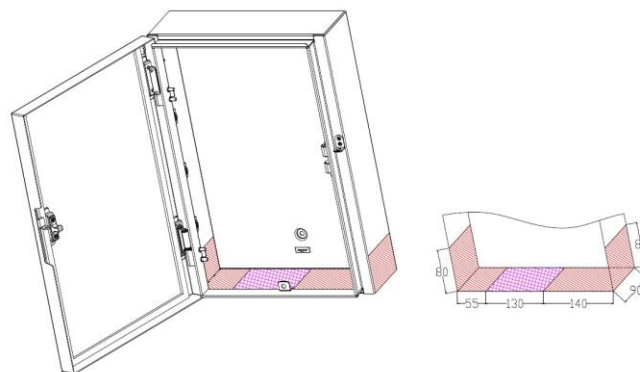

**WARNING:** Drill only in the specified areas. Unauthorized drilling may damage the aHub's protective features. To avoid damage to equipment, completely shield all aHub interior electrical boards and components before you drill or punch holes to prevent aluminum shavings and dust from falling into the aHub.

The home's power distribution should be made using appropriate cables and conduits in accordance with NFPA 70 and local AHJ requirements. If any new hole needs to be drilled, appropriate tools should be used to drill the hole.

The aHub is shipped in a protective film. When drilling new holes on the aHub, unwrap the outer film and use it to protect the components inside the aHub, as shown below. Keep the film in place while drilling and punching holes. Remove all dust and debris before unwrapping the aHub for mounting.

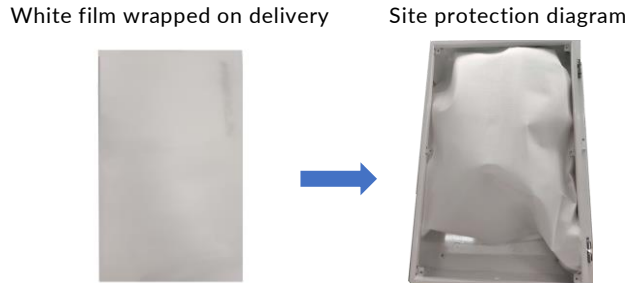

### Mount the aHub on a wall

Follow the steps below to mount the aHub on a wall.

**Step 1** Using a Phillips head screwdriver or an electric screwdriver with a Phillips head screw bit, loosen the M5 x 12 combination screw on the inner panel. Remove the screw, and the inner panel. Properly store the inner panel and screw for later use.

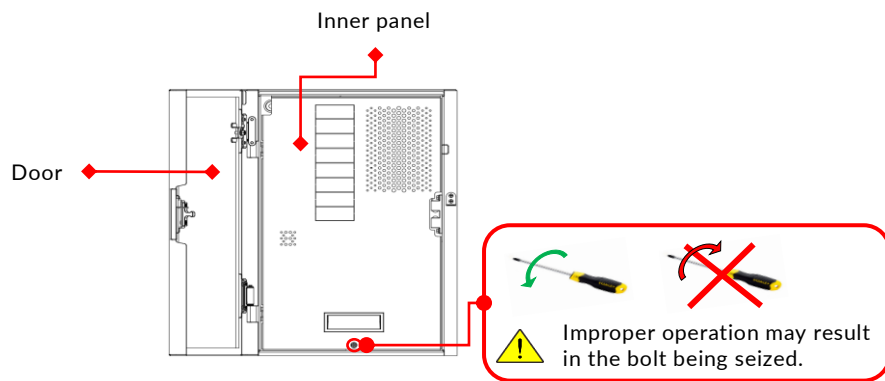

**Step 2** Place the aHub at the planned installation position. Adjust the aHub to level and then mark the wall at the three holes on the aHub.

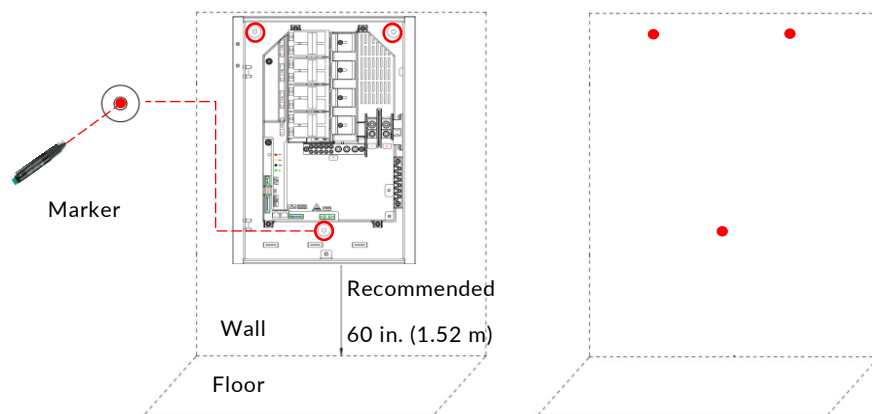

**Step 3** Using an appropriate drill bit, drill holes in the wall. Mount the aHub enclosure vertically on the wall. The water-tight washers provided must be used when mounting the aHub.

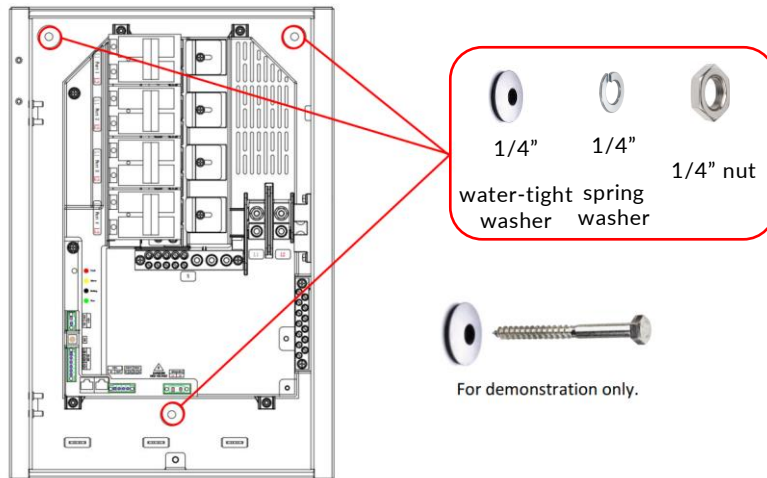

See drilling details and the fasteners in the table below for more information on the hole depth and type of fasteners to use, corresponding to different type of walls.

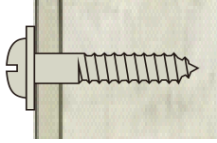
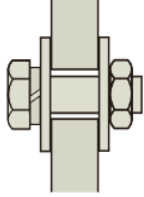
<p><b>Concrete or brick</b></p>	<p><b>Hole depth:</b> Minimum 1-1/2" (38 mm)  <b>Fastener:</b> 1/4" (6.35 mm) water-tight washer, spring washer, and nuts</p>	
<p><b>Wooden beams</b></p>	<p><b>Hole depth:</b> Minimum 2.5" (64 mm)  <b>Fastener:</b> 1/4" (6.35 mm) water-tight washer, wood screw with a large flat washer</p>	
<p><b>Steel beams</b></p>	<p><b>Hole depth:</b> Through the steel beam  <b>Fastener:</b> 1/4" (6.35 mm) water-tight washer, 1/4" (6.35 mm) stainless steel hex screws with spring washer and large flat washer and hex nuts</p>	

## Install breakers as needed

Install required breakers for Ports 1 through 4 per local laws, regulations, standards, and National Electrical Code (NEC). These breakers are not included and must be ordered separately. Refer to [Appendix for compatible breakers](#).



**WARNING:** Before installation, make sure that the aHub is de-energized and the upstream and downstream switches are disconnected and padlocked during installation.

**Step 1** Use a Phillips screwdriver to slightly loosen the M4 x 10 screw on the breaker clamp and slide the clamp left.

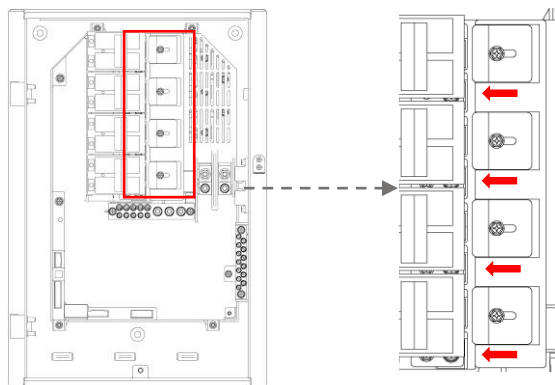

**Step 2** Using a Phillips head torque screwdriver, tighten the M4 screw to 1.03 lbf·ft (1.4 Nm).

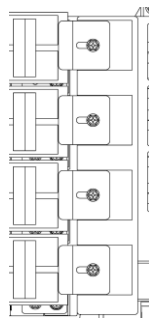

## Wiring

### Install Electrical Conduit

The image below shows an example of conduit and fitting for different applications. The image below shows an example of conduit and fitting for different applications.

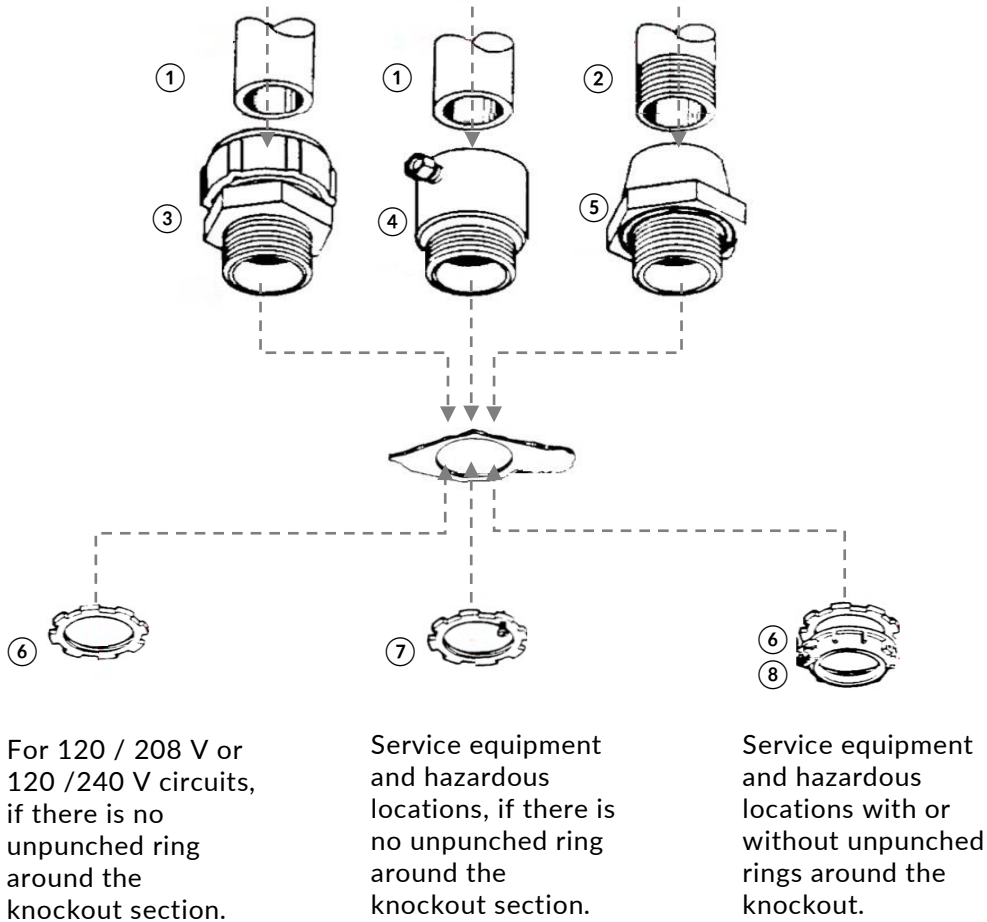

No.	Description
1	Threadless rigid metal conduit or intermediate metal conduit.
2	Threaded rigid metal conduit or intermediate metal conduit
3	Threadless fitting
4	Screw fitting
5	Sealing hub
6	Locknut
7	Bonding knockout
8	Bonding & grounding bushing



**WARNING:** The conduits and related materials must comply with UL 746B requirements as well as all local laws and regulations.

Metallic conduits and fittings are recommended to minimize electromagnetic interference.

Install electrical conduit of the appropriate size based on the planned on-site drilling locations.

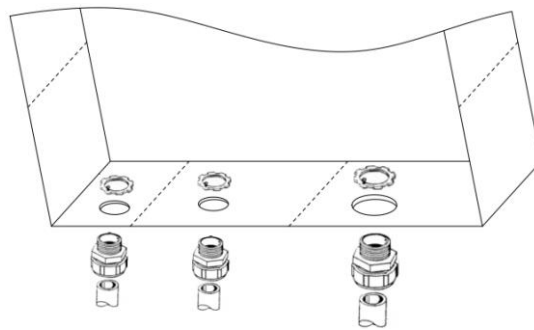

## Communications connections

### NOTE

- It is recommended to install the communications cable in a conduit to avoid accidental damage and equipment failure. If the network cable and the power cable share the same conduit, use a shielded network cable (RJ45 cable end with metal connector).
- Before connecting the communications cable, use a network cable tester to ensure that the cable contact is error-free.
- When communicating with the aHub, select either CAN or RS485 communications. Do not use both at the same time.
- Before establishing system communications connections, the MAC 1 or aGate must be installed first. There is no specific order required for the aHub and aPower.
- CAN communications is recommended for distances up to 50 m. For distances between 50 m and 100 m, RS485 communications must be used.



## Establish communications between the MAC, aHub, and aPower

### ➤ aHub Communications via CAN Port

Use a minimum CAT5 network cable to connect the **CAN OUT** port on the MAC to the **CAN IN** port on the aPower and then connect the **CAN OUT** port on the aPower to the **CAN IN** port on the aHub.

**Note:** For aPower S units, all CAN ports support both input and output. Port selection is flexible. Remove the matching terminals from all units except for the one in the last device.

Figure 9: MAC + aPower 2 + aHub

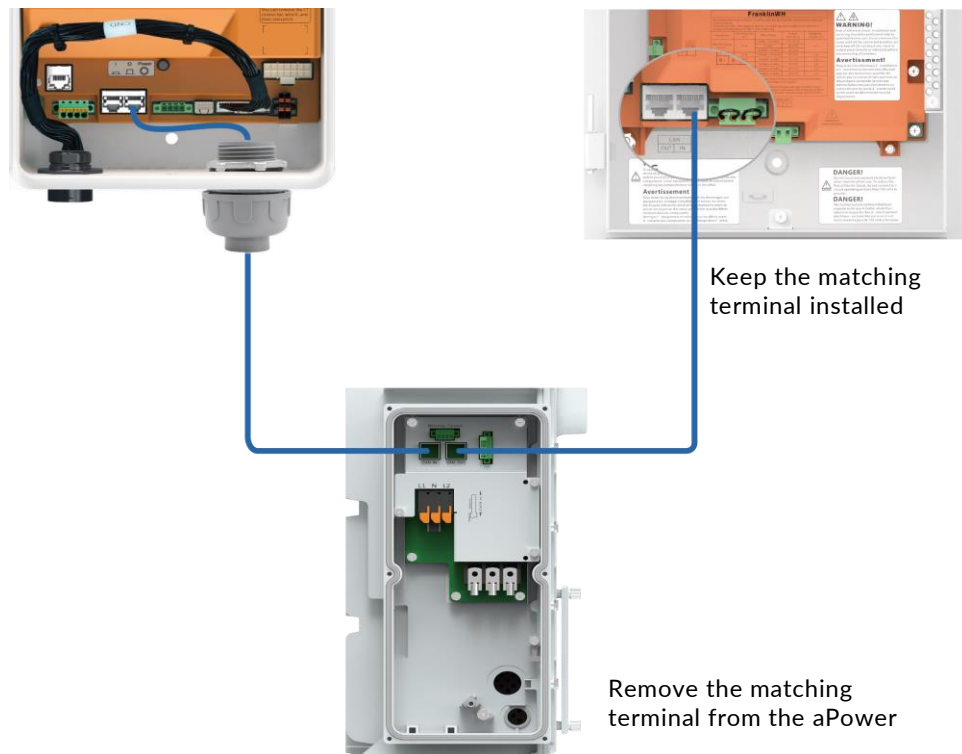
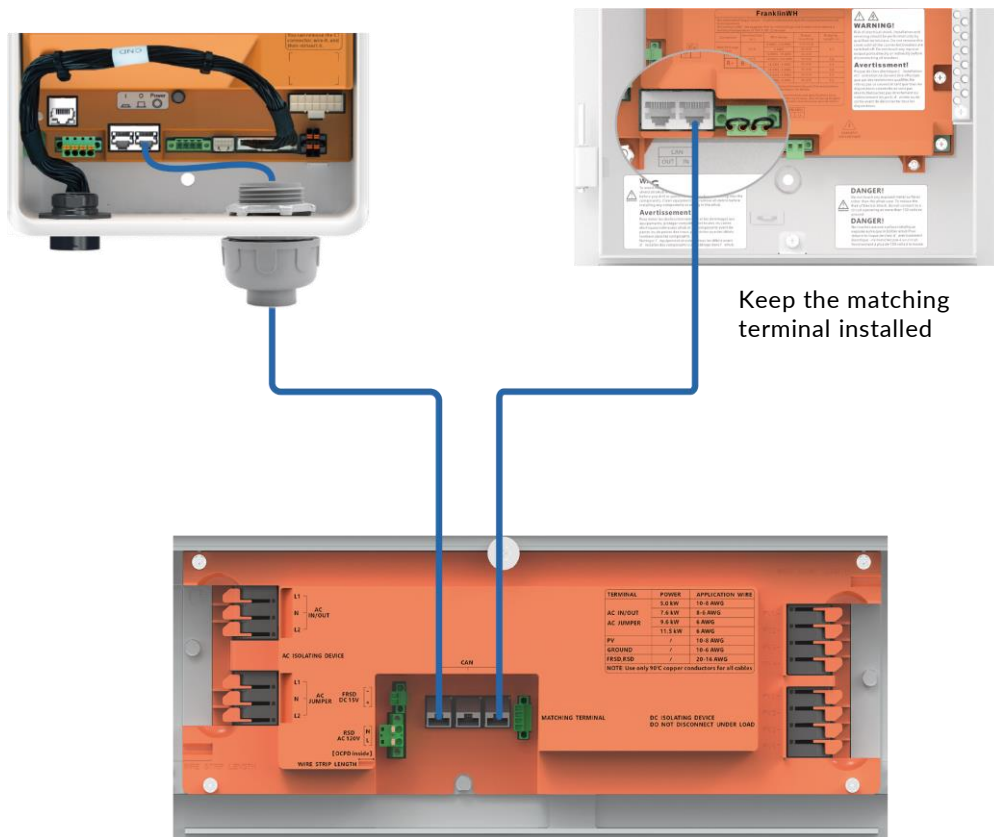

Figure 10: MAC + aPower S + aHub



Remove the matching terminal from the aPower

➤ aHub Communications via RS485 Port



**NOTE:** When using RS485 communications, the CAN port inside the aHub must not be wired. Using RS485, the V2L and generator functions will be unavailable.

Use two 22 AWG to 16 AWG cables to connect the **RS485-A1/B1** ports on the MAC to the **RS485-A1/B1** ports on the aHub.

Use a minimum CAT5 network cable to connect the **CAN OUT** port on the MAC to the **CAN IN** port on the aPower.

**Note:** For aPower S units, all CAN ports support both input and output. Port selection is flexible. Only keep the matching terminal installed on the last aPower in the series.

Figure 11: MAC + aPower 2 + aHub

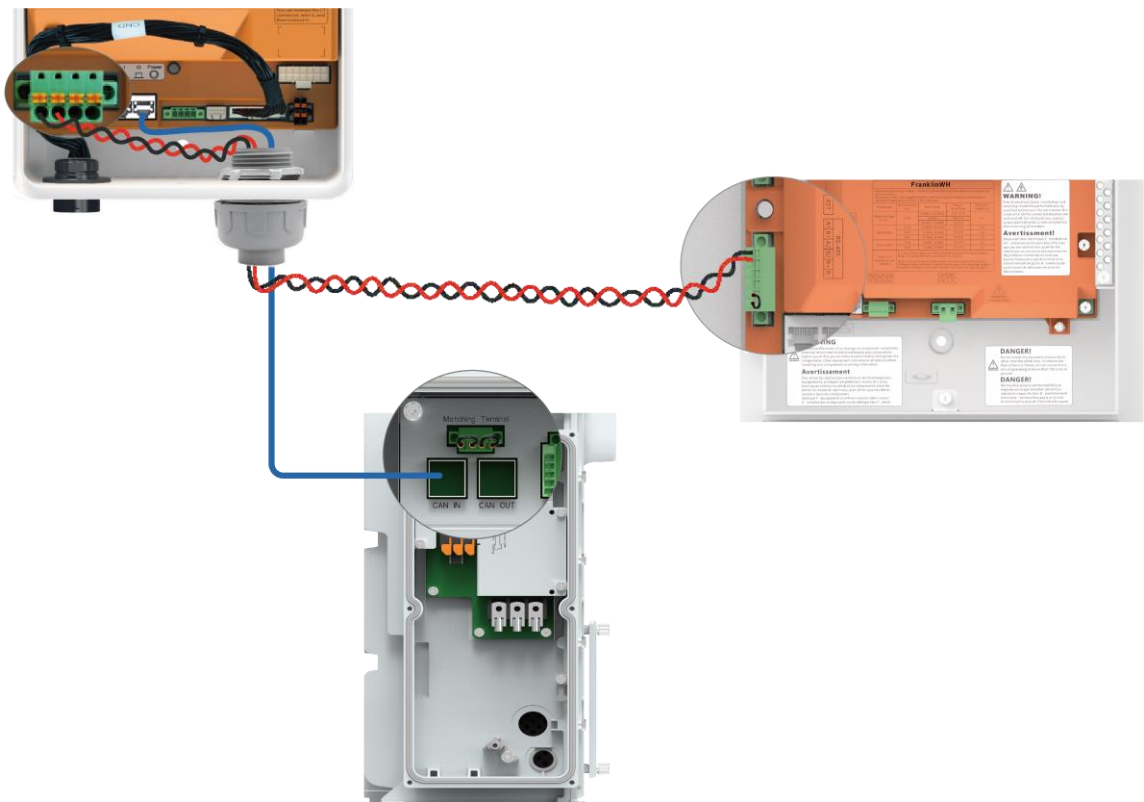

Matching terminal on last aPower

Figure 12: MAC + aPower S + aHub

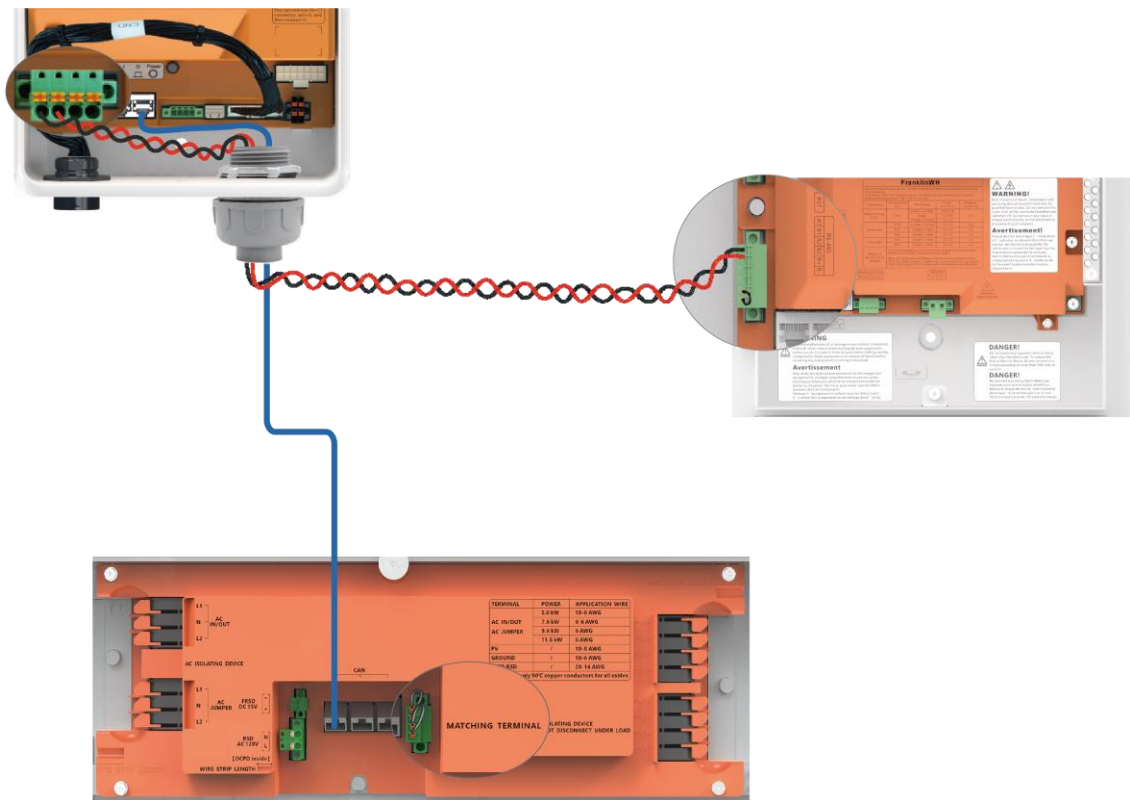

The RS485 cable length between the MAC and aHub must not exceed 328 ft (100 m). If the total distance between the MAC and aHub exceeds 328 ft (100 m), please contact [engineering@franklinwh.com](mailto:engineering@franklinwh.com) for guidance.

## Establish communications between the aGate, aHub, and the aPower

### ➤ aHub Communications via CAN Port

Use a minimum CAT5 network cable to connect the **CAN OUT** port on the aGate to the **CAN IN** port on the aPower, and connect the **CAN OUT** port on the aPower to the **CAN IN** port on the aHub.

**Note:** For aPower S units, all CAN ports support both input and output. Port selection is flexible. Remove the matching terminals from all units except for the one in the last device.

Figure 13: aGate + aPower 2 + aHub

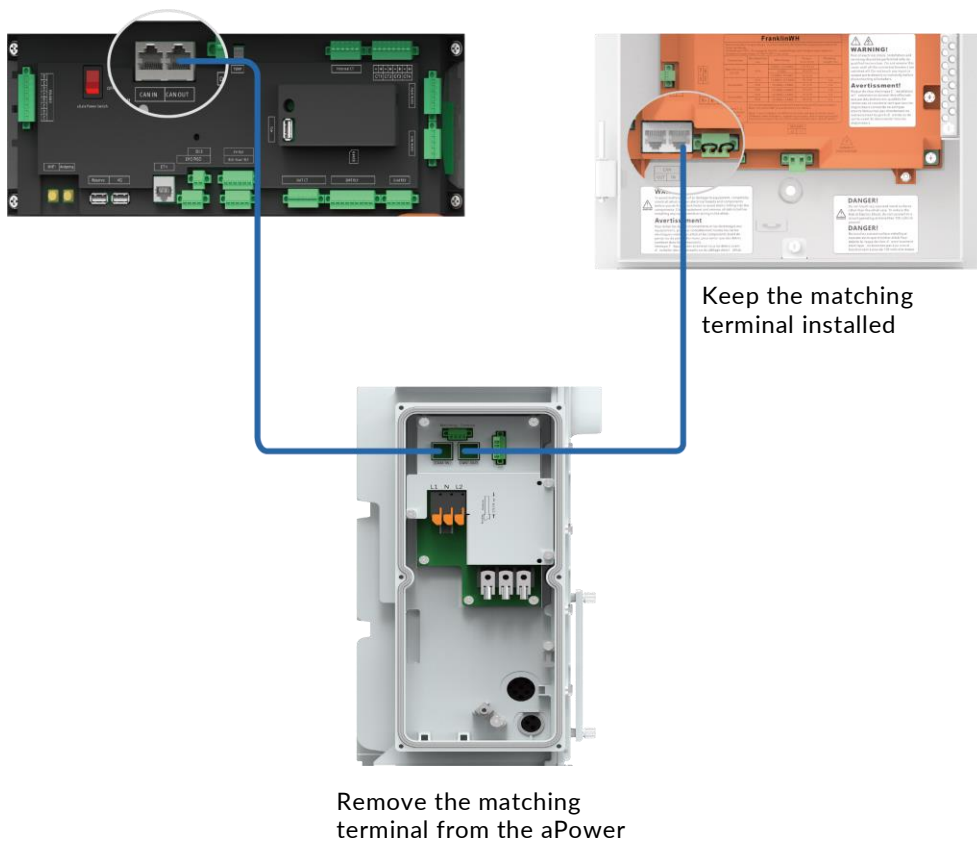
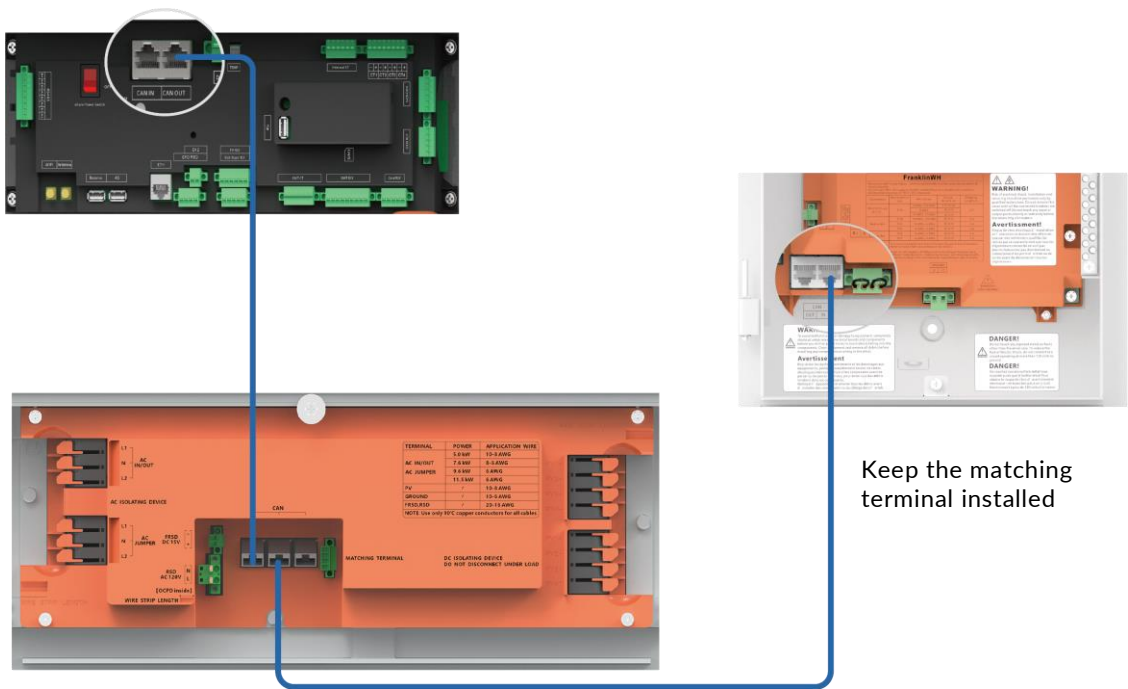

Figure 14: aGate + aPower S + aHub



Keep the matching terminal installed

Remove the matching terminal from the aPower

➤ aHub Communications via RS485 Port



**NOTE:** When using RS485 communications, the CAN port inside the aHub cannot be wired, and the V2L and generator functions will be unavailable.

Use two 22 AWG to 16 AWG cables to connect the **RS485-A1/B1** ports on the aGate to the **RS485-A1/B1** ports on the aHub.

Use a minimum CAT5 network cable to connect the **CAN OUT** port on the aGate to the **CAN IN** port on the aPower.

**Note:** For aPower S units, all CAN ports support both input and output. Port selection is flexible. Only keep the matching terminals installed on the aPower.

Figure 15: aGate + aPower 2 + aHub

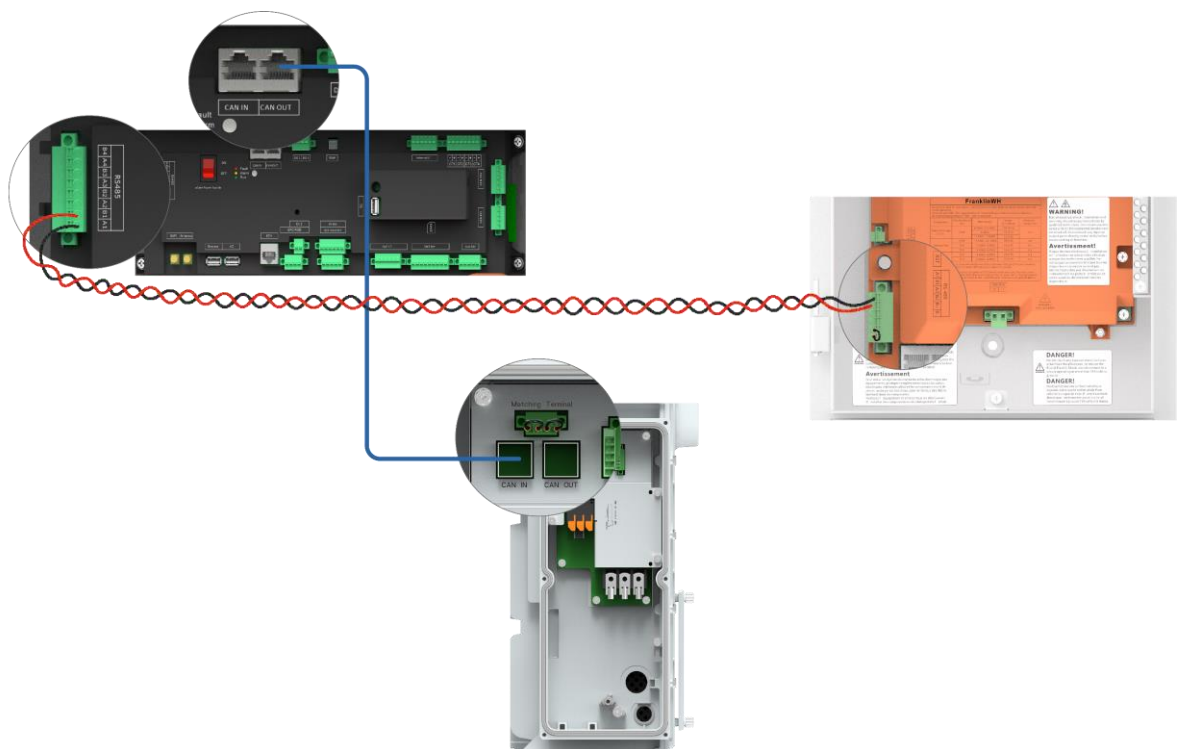

Keep the matching terminal installed

Figure 16: aGate + aPower S + aHub

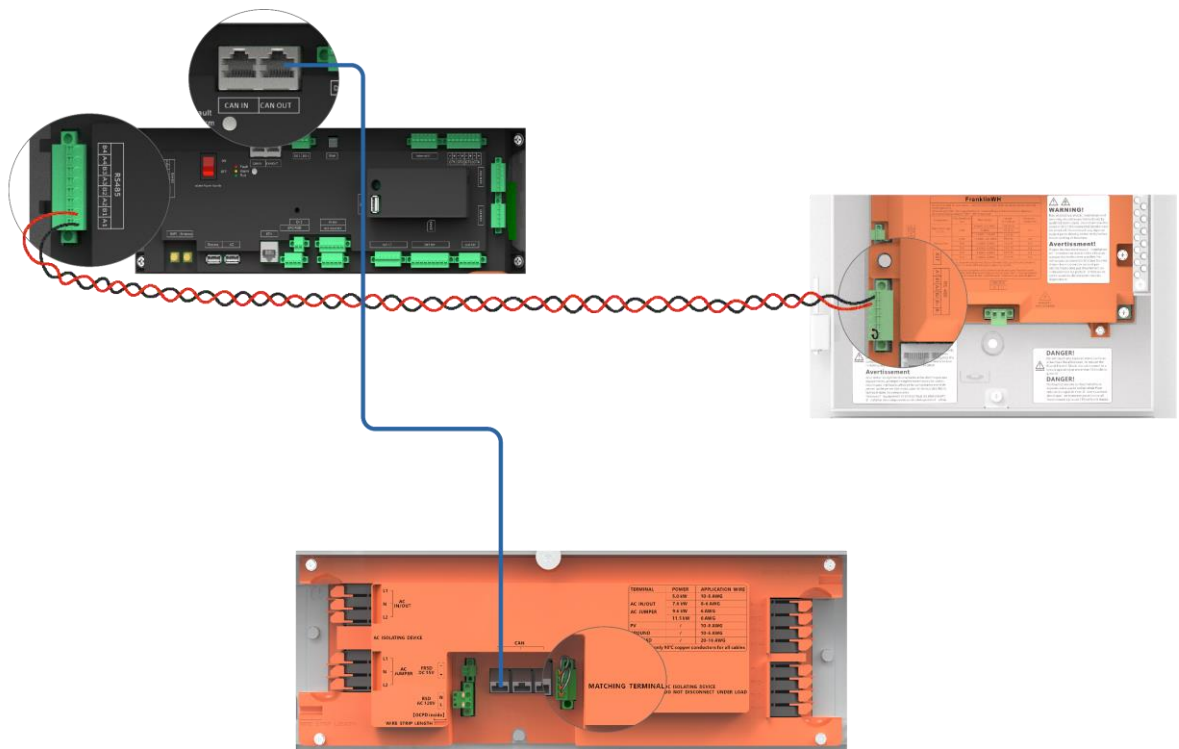

Keep the matching terminal installed

The RS485 cable length between the aGate and aHub must not exceed 328 ft (100 m). If the total distance between the aGate and aHub exceeds 328 ft (100 m), please contact [engineering@franklinwh.com](mailto:engineering@franklinwh.com) for guidance.

## Electrical Wiring



### NOTE

- The wiring of breakers should follow the specific breaker instructions. The power sources must be connected to the aHub at the corresponding ports.
- Refer to the breaker specifications for the tightening torque value for the breaker output cable screws.
- The ground cable does not pass through the circuit breaker.

### Connect the Smart Circuits (optional)

A single aHub supports up to four 240 Vac load circuits or eight 120 Vac Smart Circuits.

Wiring for each Smart Circuit should follow the configurations shown below for the Port 1 connection.

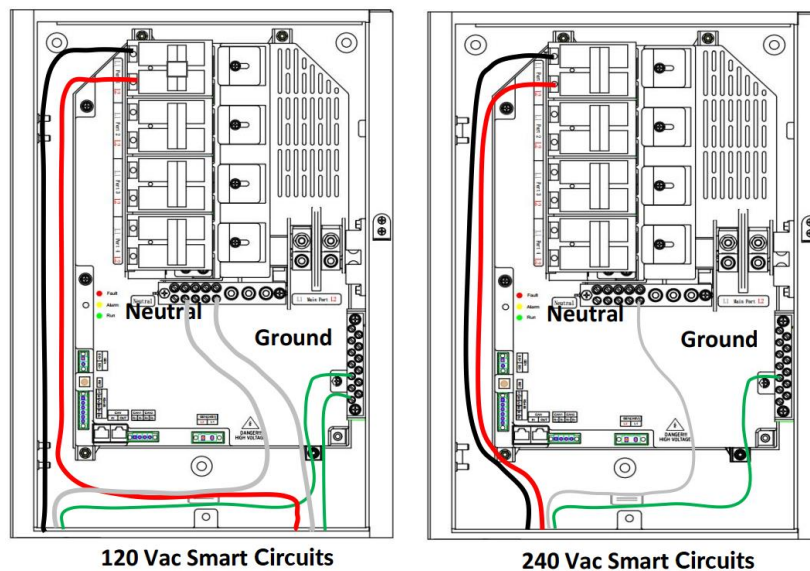

## Connect the PV inverter to the aHub

A single aHub can support up to three 240 Vac PV circuits.

An aHub supports only 240 Vac PV connections, which should be wired using L1, L2, and Ground, as shown below for the Port 2 connection. Ports 3 and 4 can follow the same connection method as Port 2.

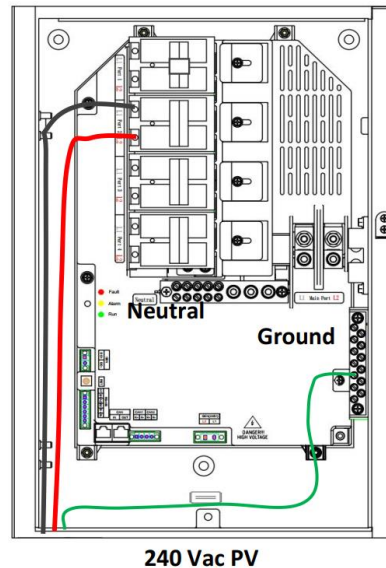

## Connect a Standby Generator to the aHub

Only aHub Port 4 supports 240 Vac standby generator access and is compatible with voltage sensing, ATS and dry contact generators, enabling automatic generator control.

---

### NOTE

- The non-relay-controlled PV in the system must be connected via the aHub. Otherwise, the generator cannot be started successfully.
  -  Due to differences in various generator types, the following wiring diagrams are for reference only. Refer to the specific generator instructions for actual wiring requirements.
  - The aHub communicates via a CAN port, which supports V2L and generator functions. Using the RS485 port will disable these functions.
-



For systems with both an aGate and an aHub:

- When the generator is connected to the aGate, refer to the [Generator Module Installation Guide \(SKU: ACCY-GENV1-US\)](#) or [Generator Module Installation Guide \(SKU: ACCY-GENV2-US\)](#).
- When the generator is connected to the aHub, refer to the generator wiring diagram below for the system with MAC and aHub.

A system supports only one generator connection.

➤ Voltage sensing Generator Connection

- Step 1** Connect the generator power output wires (E1, E2, NEU, GND) to the aHub Port 4 (L1, L2, Neutral & GND).
- Step 2** Connect the two 240 Vac pins to the voltage sensing port on the generator, as shown in the diagram below. Please select cables with a gauge of 18 AWG to 12 AWG, in accordance with local regulations.
- Step 3** Connect the battery charging terminal on the generator to the wire from a branch circuit of the main panel.

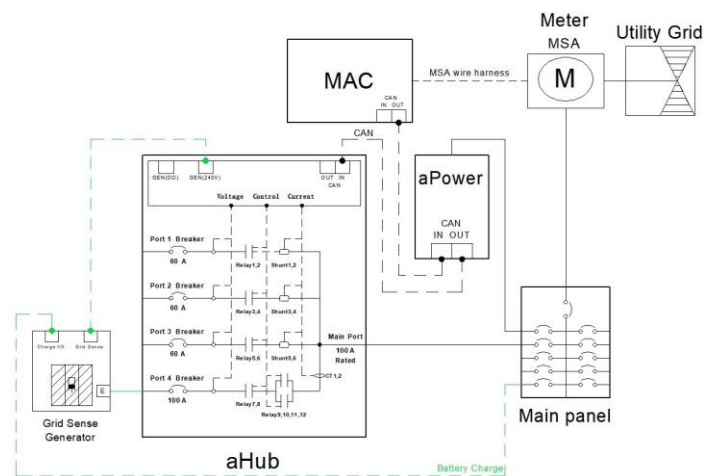
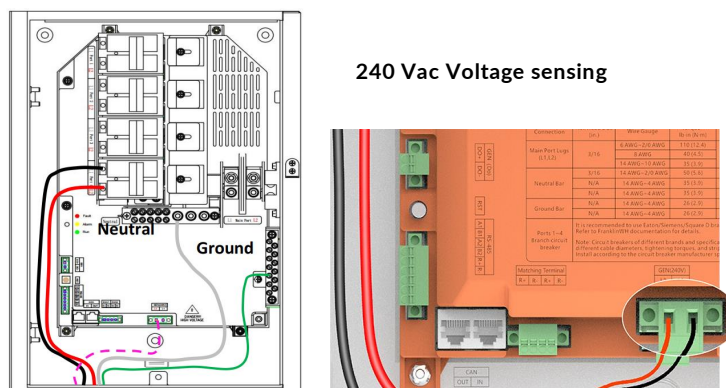

➤ **ATS Generator Connection**

- Step 1 Remove the ATS (Automatic Transfer Switch) output wires from the main panel.
- Step 2 Connect the ATS output wires to aHub Port 4 (L1, L2, Neutral & GND).
- Step 3 Remove the grid input cables from the ATS.
- Step 4 Connect the grid input cables to the grid input terminals in the main panel.
- Step 5 Connect the two 240 Vac pins to the main power input port of the ATS, as shown in the diagram below. Please select cables with a gauge of 18 AWG to 12 AWG, in accordance with local regulations.

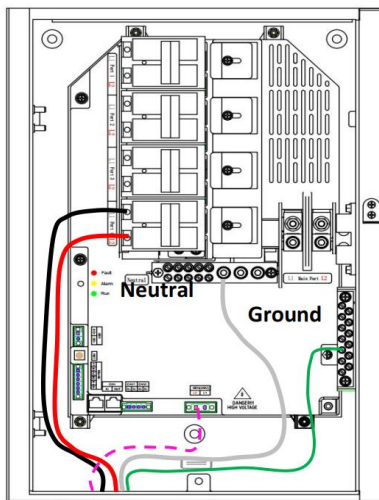

240 Vac ATS Generator

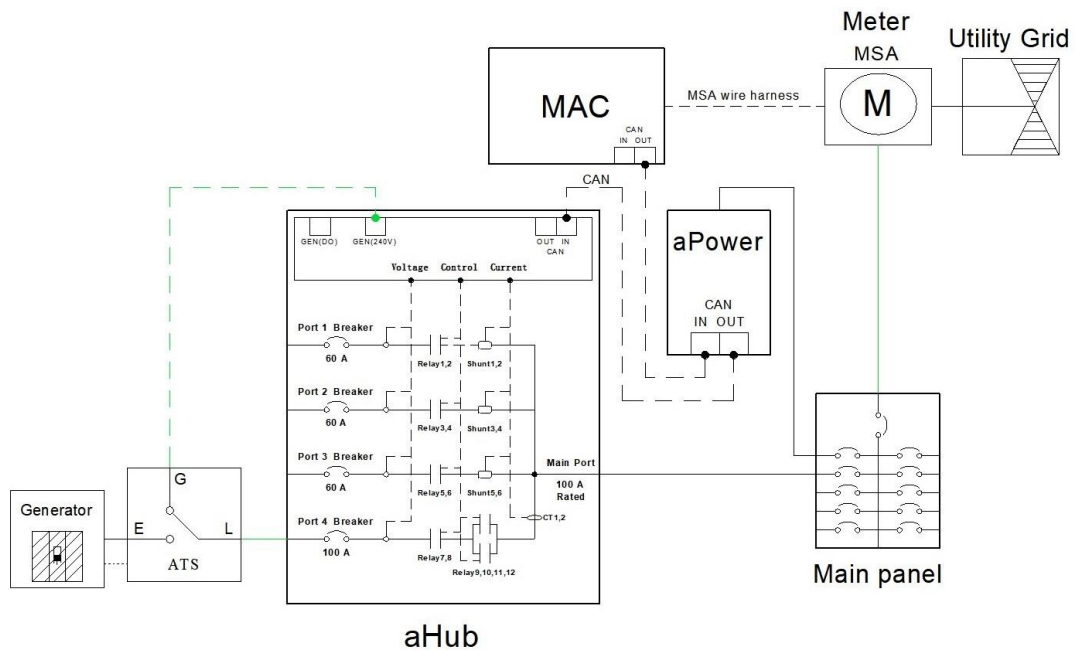
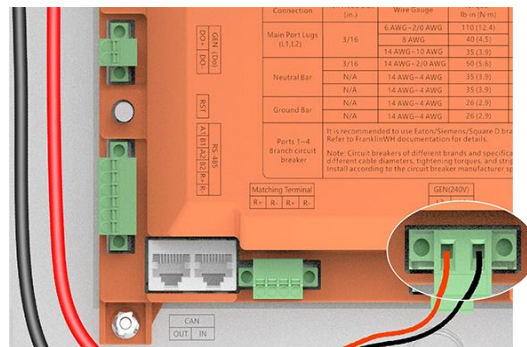

➤ **Dry Contact Generator Connection**

- Step 1** Connect the generator power output wires (E1, E2, NEU, GND) to the aHub Port 4 (L1, L2, Neutral & GND).
- Step 2** Connect the two DO pins to the two-wire starting interface on the generator, as shown in the diagram below. Select cables with a gauge of 18 AWG to 12 AWG, in accordance with local regulations.
- Step 3** Connect the battery charge terminal in the generator to the wire from a branch circuit of the main panel.

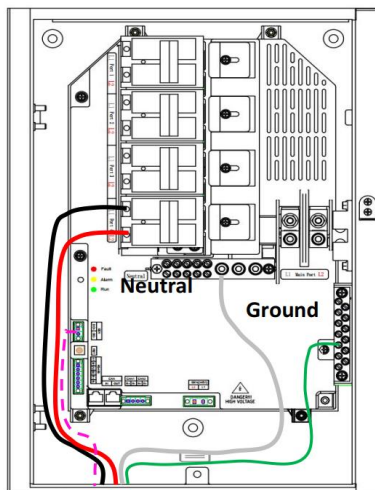

Dry Contact Generator

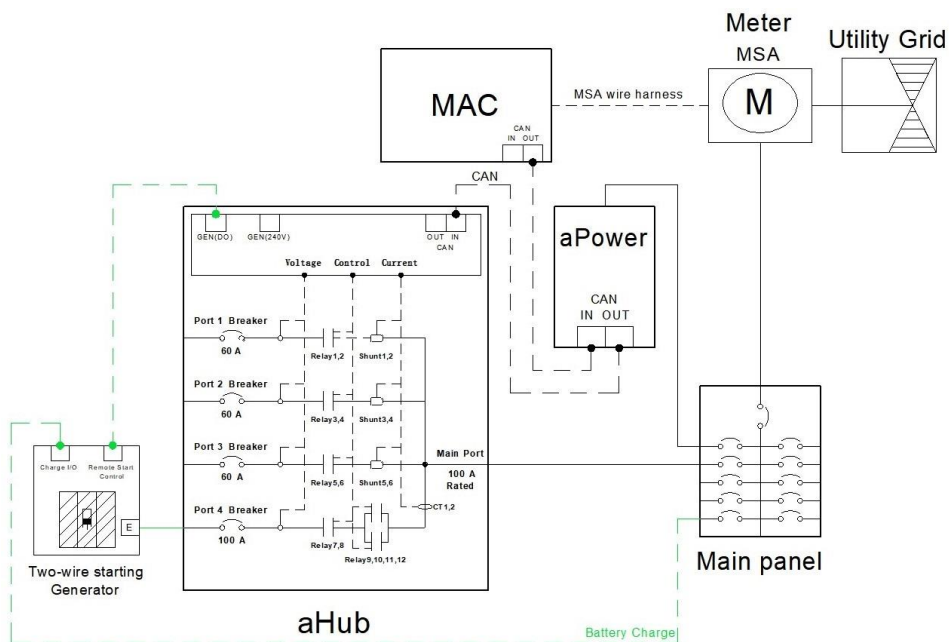
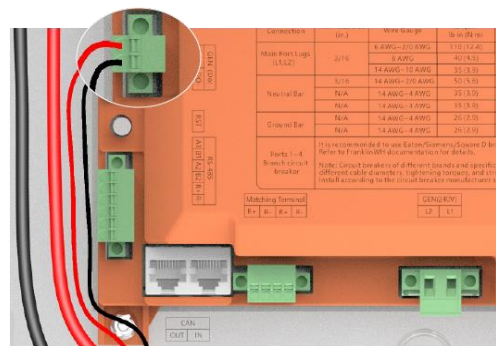

### Connect the Portable Generator to the aHub

Portable generators with 240 V output may be connected to the aHub.

Connect the generator power output wires (E1, E2, NEU, GND) to the aHub Port 4 (L1, L2, Neutral & GND).

*Note: Only 240 V portable generators are supported and Auto mode is not supported for them.*

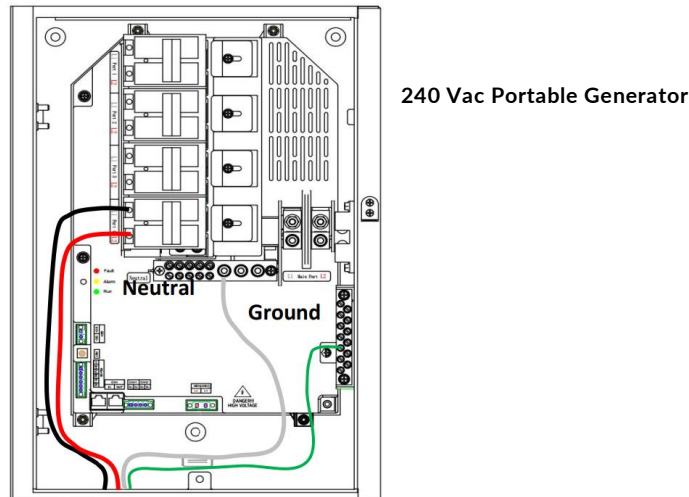

Functionality of portable generators with the FranklinWH System is not guaranteed. FranklinWH is not responsible for damage caused to the home by a portable generator or stationary generator.

It is critical that the portable generator load is kept as low as possible to avoid a potentially dangerous over voltage scenario caused by the generator and not the FranklinWH equipment.

Not following all guidelines set in the portable generator’s documentation may damage appliances, cause fires, injury or loss of life.

## Connect the Electric Vehicle (EV) to the aHub

aHub Port 4 only supports 240 Vac EV access (check EV Owner's Manual to confirm voltage output from EVPE outlet feature with integrated GFCI indicator and trip reset).

### NOTE



- The non-relay-controlled PV in the system must be connected via the aHub. Otherwise, EV charging cannot be started.
- The aHub communicates via a CAN port, which supports V2L and generator functions. Using the RS485 port will disable these functions.
- NEC guidance (625.60, 250.34, 250.20) for vehicle-mounted generators with GFCI receptacles connected to utilization equipment (V2L inlet connection) through cord-and-plug connections shall not be required to be connected to a grounding electrode.

Connect the EV power output wires to the aHub Port 4 (L1, L2, Neutral), as shown below. To simplify the aHub connection for the EV, the installer may choose an appropriate inlet box and cables for easy connection.

**Note:** When connecting to an EV, separate the outlet ground from the inlet box.

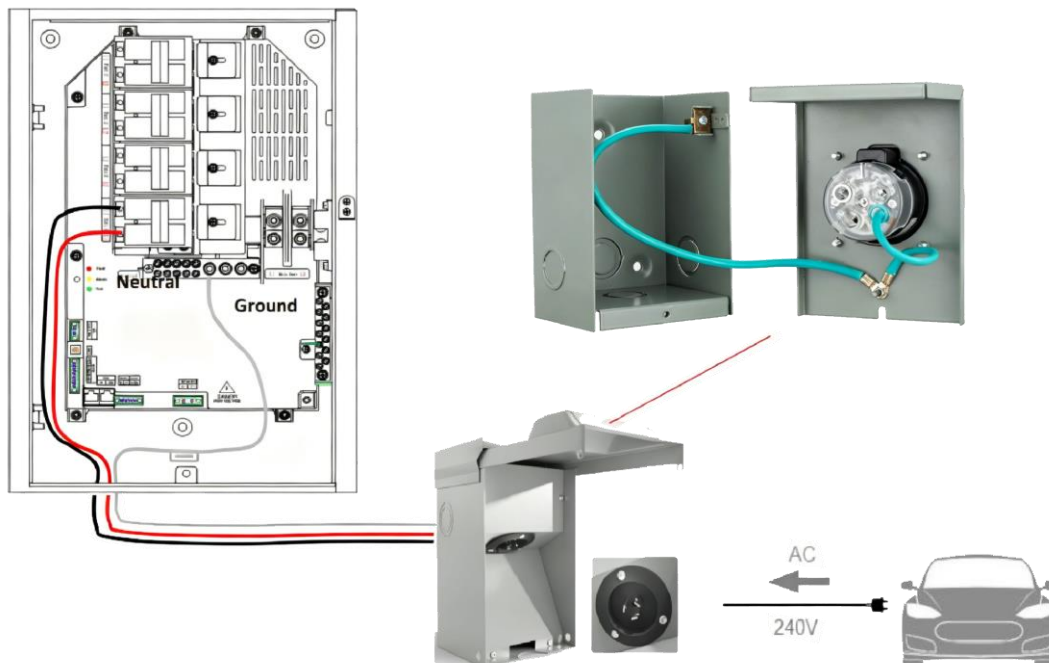

### Connect the aHub to the Main Panel



**NOTE:** Use ONLY copper conductors with a temperature rating of 194° F (90° C) for aPower connections.

Follow these guidelines when wiring one aHub to the main panel:

- Use one (1) pair of wires for a single aHub connection to the 2-pole breaker on the main panel.
- Strip the aHub port cable to the length indicated on the aHub label.
- To connect the other end of the cable to the main panel breaker, determine the cable stripping length based on the breaker configured.

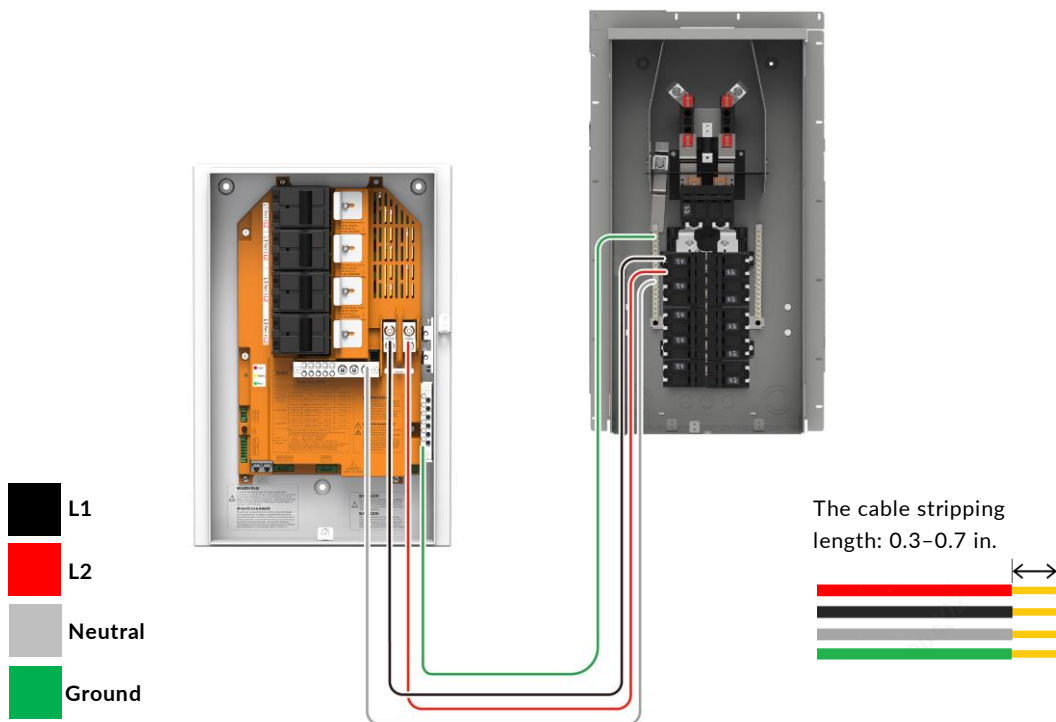

Connection	Hex Head Size (in.)	Wire Gauge	Torgue lb·in (N·m)	Stripping Length (in.)
Main Port Lugs (L1, L2)	3/16	6 AWG~2/0 AWG	110 (12.4)	0.7
		8 AWG	40 (4.5)	
		14 AWG~10 AWG	35 (3.9)	
Neutral Bar	3/16	14 AWG~2/0 AWG	50 (5.6)	0.8
	N/A	14 AWG~4 AWG	35 (3.9)	0.4
	N/A	14 AWG~4 AWG	35 (3.9)	0.8
Ground Bar	N/A	14 AWG~4 AWG	26 (2.9)	0.3
	N/A	14 AWG~4 AWG	26 (2.9)	0.5

## Complete Installation

**Step 1.** Remove the knockouts on the inner panel according to the installed breakers.

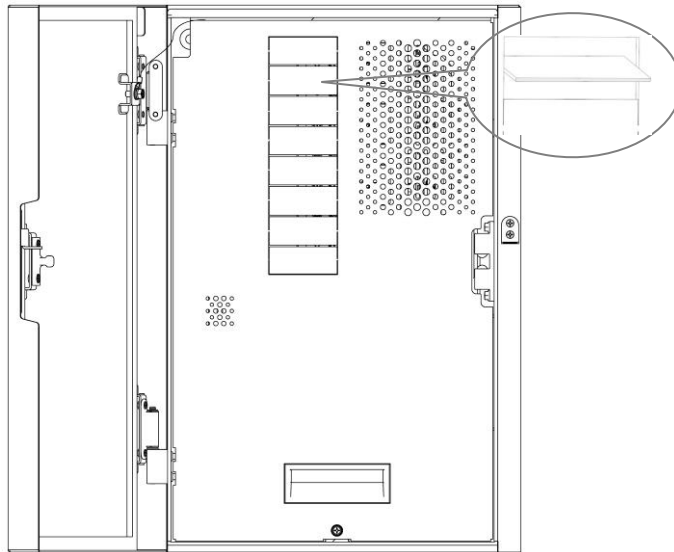

**Step 2.** Install the inner panel and fasten it by tightening an original M5 x 12 combination bolt to 2.21 lbf·ft (3.0 Nm).

**Step 3.** Close the aHub door. Press the middle latch to ensure that the door is tightly closed without any gap.

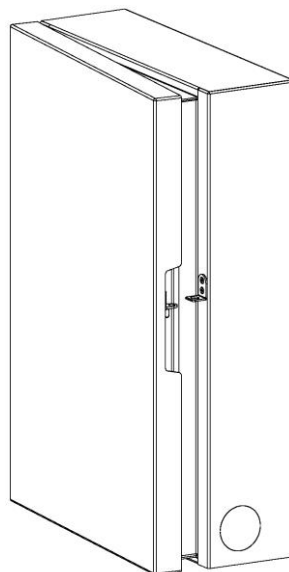

## Configure the aHub using the FranklinWH App

The aHub works with the FranklinWH App. Keep the app up to date for normal operations. You can install the latest version of the app from the Apple App Store and Google Play Store.

For more information, refer to FranklinWH Commissioning Guide.



## Technical Support

For further support, please contact your installer or the FranklinWH service team at [www.franklinwh.com/support](http://www.franklinwh.com/support). Please be prepared to provide the following information before you contact FranklinWH:

- Owner name
- Your preferred desired contact method (name, phone number, email)
- The serial number of your aHub (as shown in the figure below) status
- A brief description of your problem



## Appendix 1: Allowed Breakers

1-Pole Breaker					
S/N	Description	Port NO.	Manufacturer & Model 1	Manufacturer & Model 2	Manufacturer & Model 3
1	1-Pole, 10 kAIC	Port 1~4	Eaton #BR115	Siemens #Q115	Schneider #HOM115
2	1-Pole, 10 kAIC	Port 1~4	Eaton #BR120	Siemens #Q120	Schneider #HOM120
3	1-Pole, 10 kAIC	Port 1~4	Eaton #BR130	Siemens #Q130	Schneider #HOM130
4	1-Pole, 10 kAIC	Port 1~4	Eaton #BR140	Siemens #Q140	Schneider #HOM140
5	1-Pole, 10 kAIC	Port 1~4	Eaton #BR150	Siemens #Q150	Schneider #HOM150
6	1-Pole, 10 kAIC	Port 1~4	Eaton #BR160	Siemens #Q160	N/A
7	1-Pole, 10 kAIC	Port 4	Eaton #BR170	Siemens #Q170	N/A

2-Pole Breaker					
S/N	Description	Port NO.	Manufacturer & Model 1	Manufacturer & Model 2	Manufacturer & Model 3
1	2-Pole, 10 kAIC	Port 1~4	Eaton #BR215	Siemens #Q215	Schneider #HOM215
2	2-Pole, 10 kAIC	Port 1~4	Eaton #BR220	Siemens #Q220	Schneider #HOM220
3	2-Pole, 10 kAIC	Port 1~4	Eaton #BR230	Siemens #Q230	Schneider #HOM230
4	2-Pole, 10 kAIC	Port 1~4	Eaton #BR240	Siemens #Q240	Schneider #HOM240
5	2-Pole, 10 kAIC	Port 1~4	Eaton #BR250	Siemens #Q250	Schneider #HOM250
6	2-Pole, 10 kAIC	Port 1~4	Eaton #BR260	Siemens #Q260	Schneider #HOM260
7	2-Pole, 10 kAIC	Port 4	Eaton #BR270	Siemens #Q270	Schneider #HOM270
8	2-Pole, 10 kAIC	Port 4	Eaton #BR280	Siemens #Q280	Schneider #HOM280
9	2-Pole, 10 kAIC	Port 4	Eaton #BR290	Siemens #Q290	Schneider #HOM290
10	2-Pole, 10 kAIC	Port 4	Eaton #BR2100	Siemens #Q2100	Schneider #HOM2100

**Note:** This table lists common circuit breakers with different current ratings. If using a different rating, ensure the total current per phase does not exceed the maximum recommended on the label. If suitable for your application, a 2-Pole Quadplex Breaker is optional.

GFCI breakers for aHub Port 1 -4 Smart Circuit use			
S/N	Model 1	Current	Description
1	BRN215EP	15 A	Eaton BR GFEP circuit breaker, ground fault equipment protection circuit breaker, pigtail neutral, 15 A, 10 kAIC, 2-Pole, 120/240 V, #14-4 AWG
2	BRN220EP	20 A	EATON BR GFEP circuit breaker, ground fault equipment protection circuit breaker, pigtail neutral, 20 A, 10 kAIC, 2-Pole, 120/240 V, #14-4 AWG
3	BRN225EP	25 A	EATON BR GFEP circuit breaker, ground fault equipment protection circuit breaker, pigtail neutral, 25 A, 10 kAIC, 2-Pole, 120/240 V, #14-4 AWG
4	BRN230EP	30 A	EATON BR GFEP circuit breaker, ground fault equipment protection circuit breaker, pigtail neutral, 30 A, 10 kAIC, 2-Pole, 120/240 V, #14-4 AWG
5	BRN240EP	40 A	EATON BR GFEP circuit breaker, ground fault equipment protection circuit breaker, pigtail neutral, 40 A, 10 kAIC, 2-Pole, 120/240 V, #14-4 AWG
6	BRN250EP	50 A	EATON BR GFEP circuit breaker, ground fault equipment protection circuit breaker, pigtail neutral, 50 A, 10 kAIC, 2-Pole, 120/240 V, #14-4 AWG
7	BRN260EP	60 A	EATON BR GFEP circuit breaker, ground fault equipment protection circuit breaker, pigtail neutral, 60 A, 10 kAIC, 2-Pole, 120/240 V, #14-4 AWG

**NOTE:** The installation of the aHub must comply with all applicable codes and requirements set by the local AHJ and/or the state.

Use GFCI breakers **only** for Smart Circuits Module in aHub. Do not connect them to an aPower, PV, or generator/V2L.

## Appendix 2: Revision History

Revision	Date	Description
V1.3	2026-06-16	<ul style="list-style-type: none"><li>Updated communications distance recommendations for CAN and RS485 connections.</li><li>Added GFCI breakers for aHub Port 1 - 4 Smart Circuits.</li></ul>
V1.2	2026-04-30	<ul style="list-style-type: none"><li>Updated the portable generator description.</li><li>Added notes on installation orientation and environmental protection for outdoor installations.</li></ul>
V1.1	2026-04-17	<ul style="list-style-type: none"><li>Added support for communications via the RS485 port on the aHub.</li><li>Updated system configuration to allow the generator to be connected to the aHub when using both aGate and aHub.</li></ul>
V1.0	2026-01-22	Initial release.